

修订 REV	标记 MARK	修改摘要 REVISION DESCRIPTION	签名 SIGNATURE	日期 DATE
AO		NEW RELEASE	WANG	2011-03-21

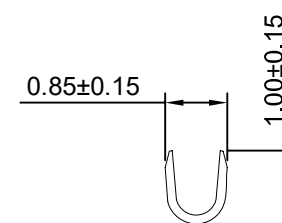

SEC: A-A

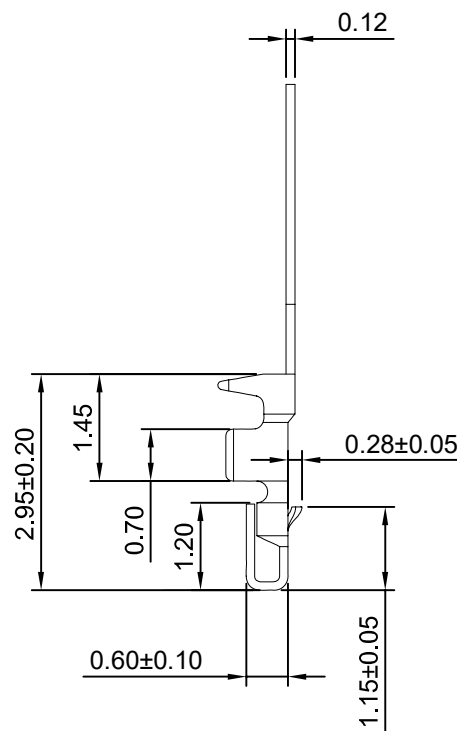
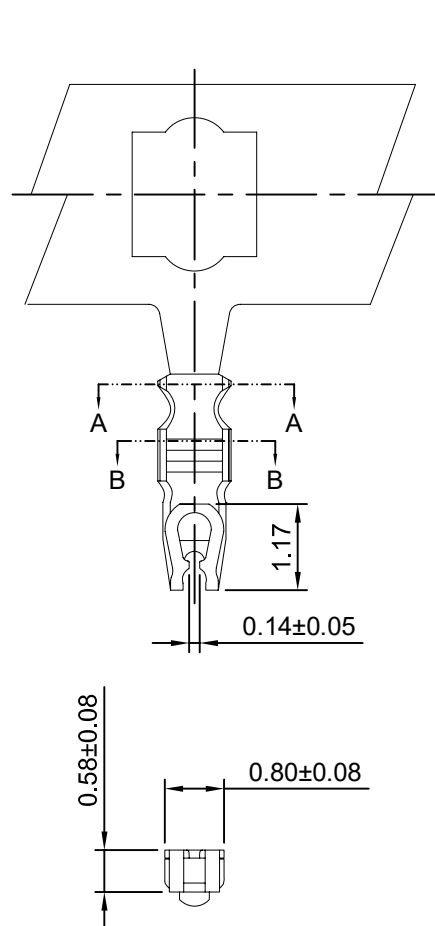
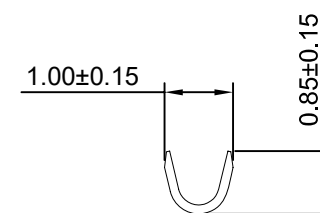

SEC: B-B

Ordering information & Specifications

Unit:mm

Part No	Wire Range	Insultion O.D.	Material	Finish	Qty/reel
HDGC1201-GP-A	AWG#28-#32	0.63mm(max)	Phosphor Bronze	Gold over Nickel	15,000 PCS



深圳市华德共创科技有限公司

Shenzhen Huade co-create Technology Co.,LTD

TEL : 0755-27129737 FAX : 0755-29940187

-TOLERANCES- UNLESS OTHERWISE SPECIFIED 公差参数表						TITLE: 1.20mm Pitch 产品名称: Crimp Terminal			
X.X	±0.30	X.X°	±3°	APPD: 核准:	XIE	PART NO: 产品编号: HDGC1201-T-A			
X.XX	±0.30	X.XX°	±2°	CHECK: 校对:	WANG	DATE	SCALE	UNIT	CODE NUMBER
X.XXX	±0.10	X.XXX°	±1°	DRAW: 绘图:	WANG	2011-03-21	10:1	mm	A008

修订 REV	标记 MARK	修改摘要 REVISION DESCRIPTION	签名 SIGNATURE	日期 DATE
AO		NEW RELEASE	WANG	2013-10-25

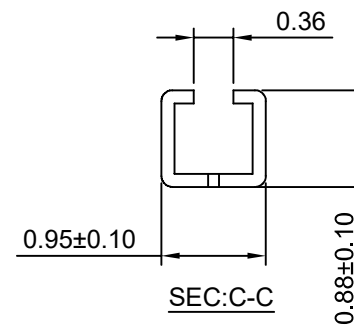
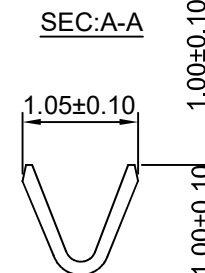
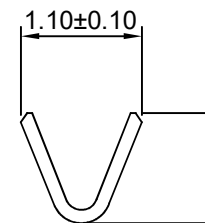
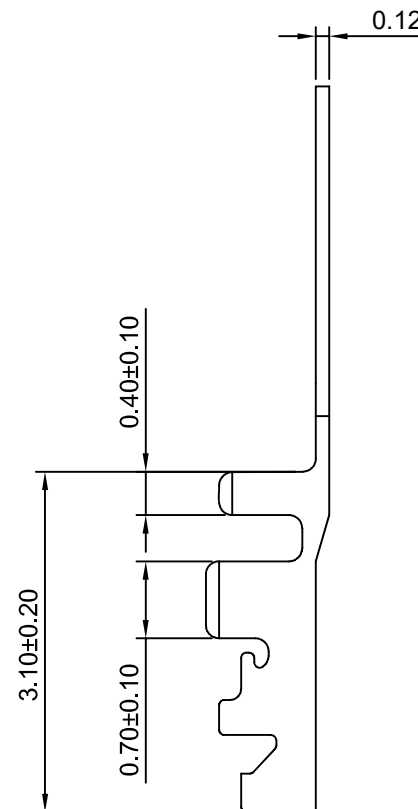
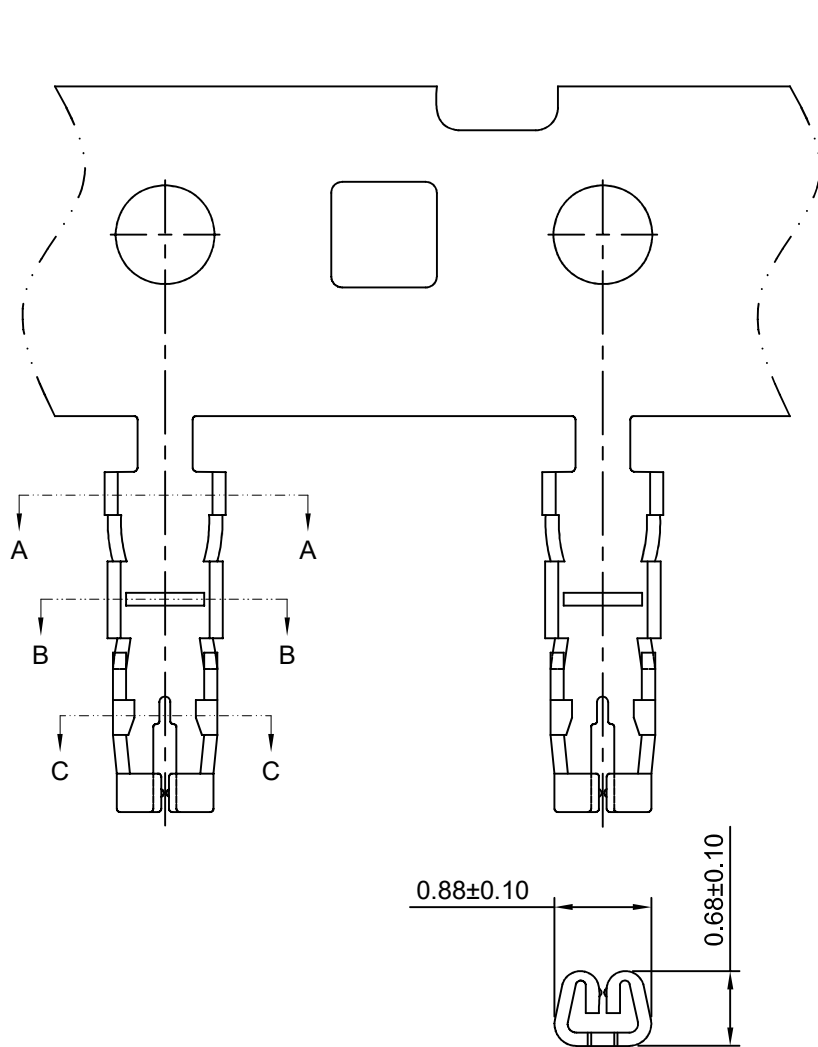

Ordering information & Specifications

Unit:mm

Part No	Wire Range	Insulation O.D.	Material	Finish	Qty/reel
HDGC1201-TP-B	AWG#28-#32	0.63mm(max)	Phosphor Bronze	Tin over Nickel	30,000 PCS
HDGC1201-GP-B	AWG#28-#32	0.63mm(max)	Phosphor Bronze	Gold over Nickel	30,000 PCS

Optional Gold plating available but MOQ requested



深圳市华德共创科技有限公司

Shenzhen Huade co-create Technology Co.,LTD

TEL : 0755-27129737 FAX : 0755-29940187

-TOLERANCES- UNLESS OTHERWISE SPECIFIED 公差参数表					TITLE: 1.20mm Pitch 产品名称: Crimp Terminal				
X.X	±0.30	X.X°	±3°	APPD: 核准:	XIE				
X.XX	±0.30	X.XX°	±2°	CHECK: 校对:	WANG	DATE	SCALE	UNIT	CODE NUMBER
X.XXX	±0.10	X.XXX°	±1°	DRAW: 绘图:	WANG	2013-10-25	15:1	mm	A008

修订 REV	标记 MARK	修改摘要 REVISION DESCRIPTION	签名 SIGNATURE	日期 DATE
AO		NEW RELEASE	WANG	2018-05-30

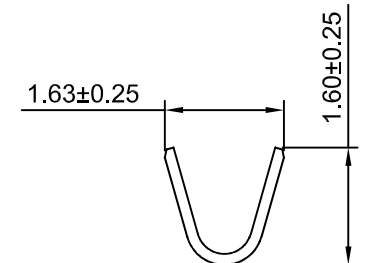
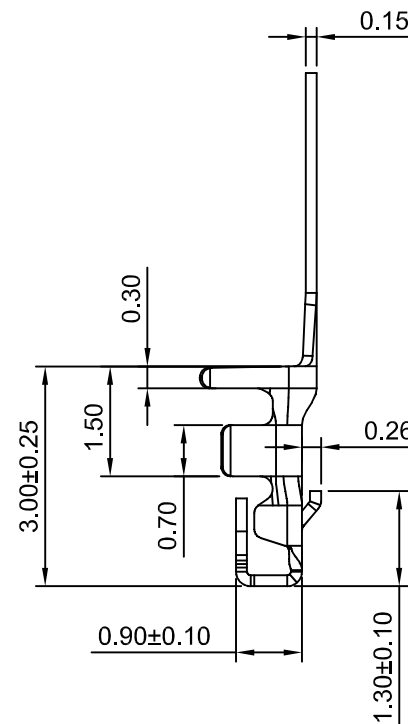
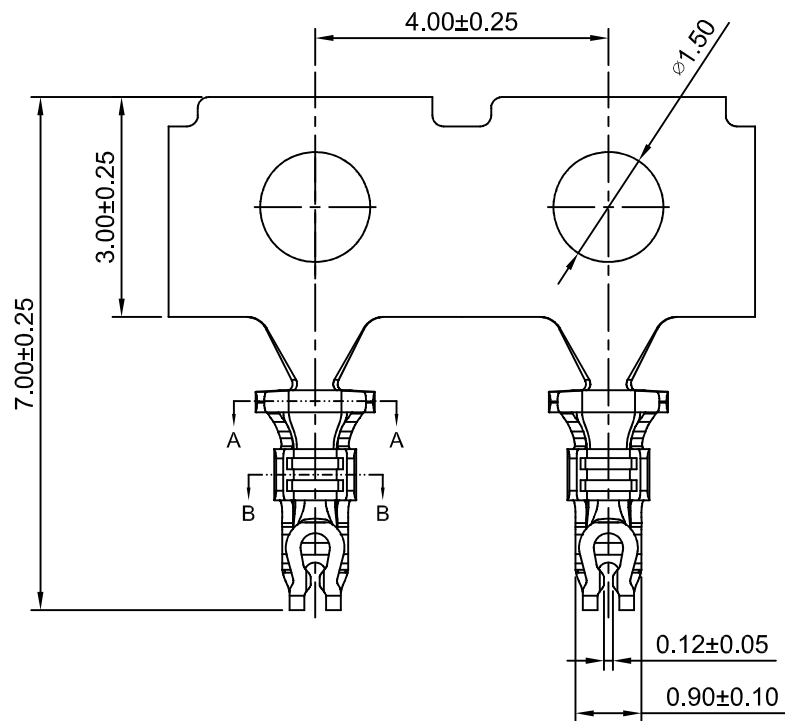

SEC:A-A

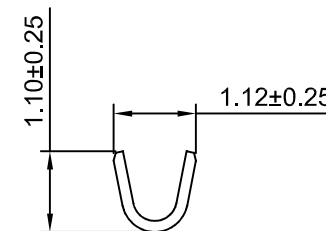

SEC:B-B

Ordering information & Specifications

Unit:mm

Part No	Wire Range	Insultion O.D.	Material	Finish	Qty/reel
HDGC1201-GP-G	AWG#26-#28	0.98mm(max)	Phosphor Bronze	Gold over Nickel	30,000 PCS



深圳市华德共创科技有限公司

Shenzhen Huade co-create Technology Co.,LTD

TEL : 0755-27129737 FAX : 0755-29940187

-TOLERANCES- UNLESS OTHERWISE SPECIFIED 公差参数表						TITLE: 1.20mm Pitch 产品名称: Crimp Terminal			
X.X	±0.30	X.X°	±3°	APPD: 核准:	XIE	PART NO: 产品编号: HDGC1201-T-G			
X.XX	±0.30	X.XX°	±2°	CHECK: 校对:	WANG	DATE	SCALE	UNIT	CODE NUMBER
X.XXX	±0.10	X.XXX°	±1°	DRAW: 绘图:	WANG	2018-05-30	10:1	mm	A008

修订 REV	标记 MARK	修改摘要 REVISION DESCRIPTION	签名 SIGNATURE	日期 DATE
AO		NEW RELEASE	WANG	2011-03-21

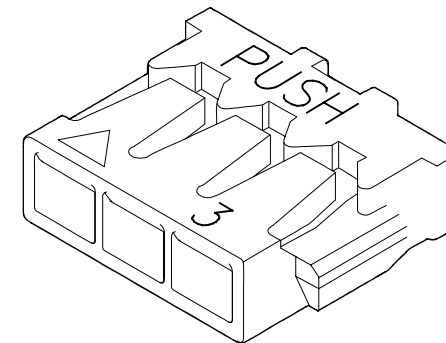
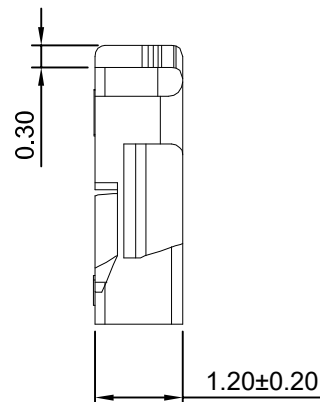
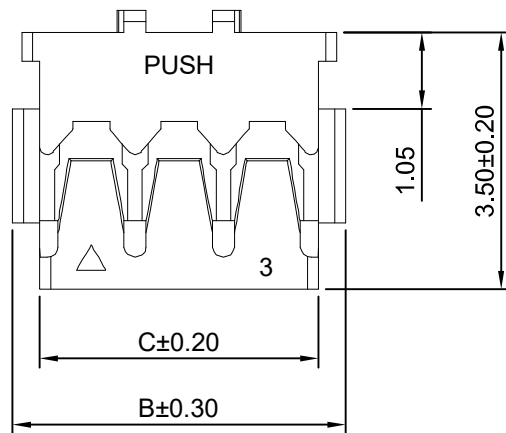
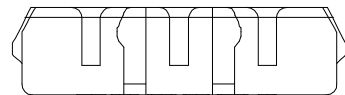

Ordering Information:

HDGC1201HA-XP - **
1 2

- Part No.
- Material:
(blank): White
BK: Black

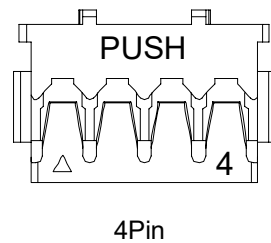
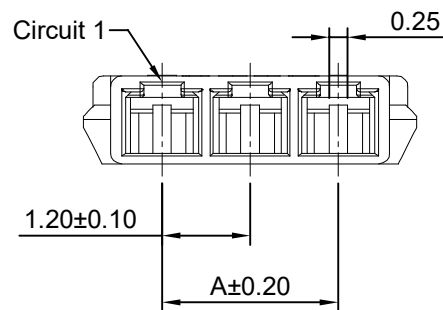

4Pin

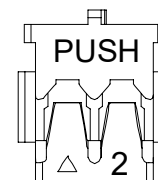

2Pin

Ordering Information & Dimensions

Circuits	Dimensions(mm)			Circuits	Dimensions(mm)		
	A	B	C		A	B	C
2P	1.20	3.35	2.60	7P	7.20	9.35	8.60
3P	2.40	4.55	3.80	8P	8.40	10.55	9.80
4P	3.60	5.75	5.00	9P	9.60	11.75	11.00
5P	4.80	6.95	6.20	10P	10.80	12.95	12.20
6P	6.00	8.15	7.40				

SPECIFICATIONS:

Current Rating: 2A AC,DC
Voltage Rating: 50V AC,DC
Temperature Range: -25°C ~ +85°C
Contact Resistance: 10MΩ Max
Insulation Resistance: 100MΩ Min
Withstanding Voltage: 500V AC/minute
Material: PBT,UL94V-0 (White)

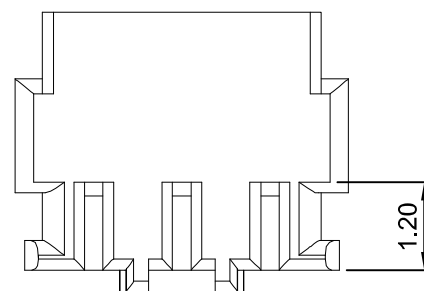

		深圳市华德共创科技有限公司 Shenzhen Huade co-create Technology Co.,LTD TEL : 0755-27129737 FAX : 0755-29940187			
-TOLERANCES- UNLESS OTHERWISE SPECIFIED 公差参数表				TITLE: 产品名称: 1.20mm Pitch Housing	
X.X	±0.30	X.X°	±3°	APPD: 核准:	XIE
X.XX	±0.30	X.XX°	±2°	CHECK: 校对:	WANG
X.XXX	±0.10	X.XXX°	±1°	DRAW: 绘图:	WANG
PART NO: 产品编号:		HDGC1201HA-XP			
DATE	SCALE	UNIT	CODE NUMBER		
2011-03-21	10:1	mm	A008		

修订 REV	标记 MARK	修改摘要 REVISION DESCRIPTION	签名 SIGNATURE	日期 DATE
AO		NEW RELEASE	WANG	2013-10-25

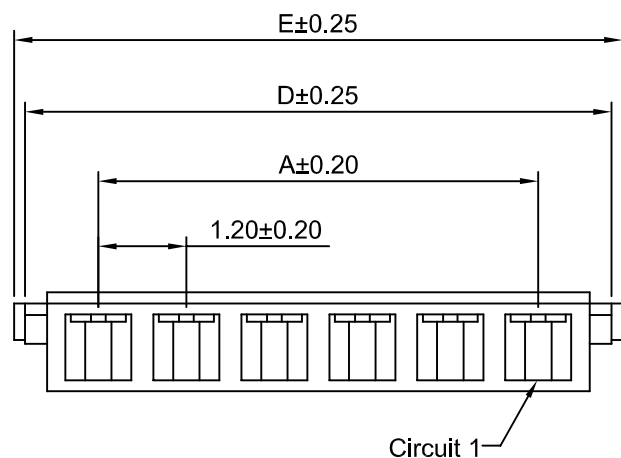
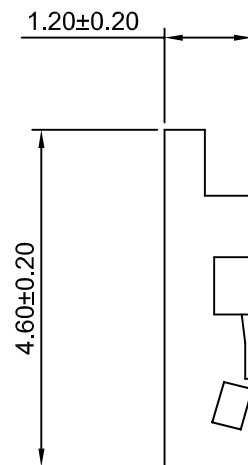
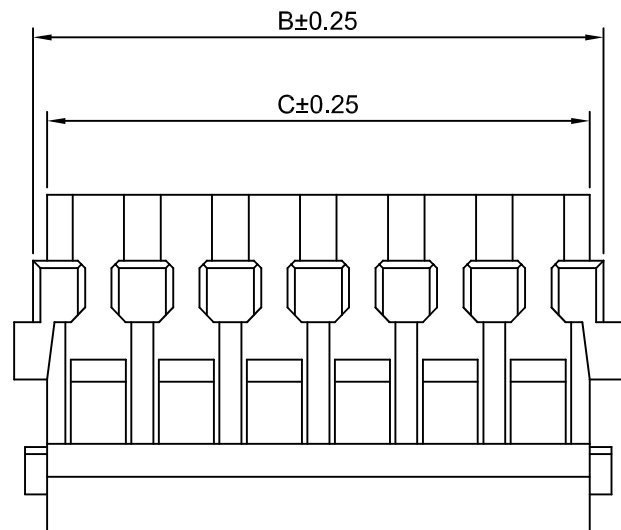

SPECIFICATIONS:
 Current Rating: 2A AC,DC
 Voltage Rating: 50V AC,DC
 Temperature Range: -25°C ~ +85°C
 Contact Resistance: 20mΩ Max.
 Insulation Resistance: 100MΩ Min.
 Withstanding Voltage: 500V AC/minute
 Material: PBT UL94V-0(Natural)

Ordering Information & Dimensions

Circuits	Dimensions(mm)				
	A	B	C	D	E
2P	1.20	2.98	2.60	3.20	3.50
3P	2.40	4.18	3.80	4.40	4.70
4P	3.60	5.38	5.00	5.60	5.90
5P	4.80	6.58	6.20	6.80	7.10
6P	6.00	7.78	7.40	8.00	8.30



深圳市华德共创科技有限公司

Shenzhen Huade co-create Technology Co.,LTD
 TEL : 0755-27129737 FAX : 0755-29940187

-TOLERANCES- UNLESS OTHERWISE SPECIFIED 公差参数表						TITLE: 产品名称 : 1.20mm Pitch Housing			
X.X	±0.30	X.X°	±3°	APPD: 核准 :	XIE	PART NO: 产品编号 : HDGC1201HB-XP			
X.XX	±0.30	X.XX°	±2°	CHECK: 校对 :	WANG	DATE	SCALE	UNIT	CODE NUMBER
X.XXX	±0.10	X.XXX°	±1°	DRAW: 绘图 :	WANG	2013-10-25	10:1	mm	A008

修订 REV	标记 MARK	修改摘要 REVISION DESCRIPTION	签名 SIGNATURE	日期 DATE
AO		NEW RELEASE	WANG	2013-10-25

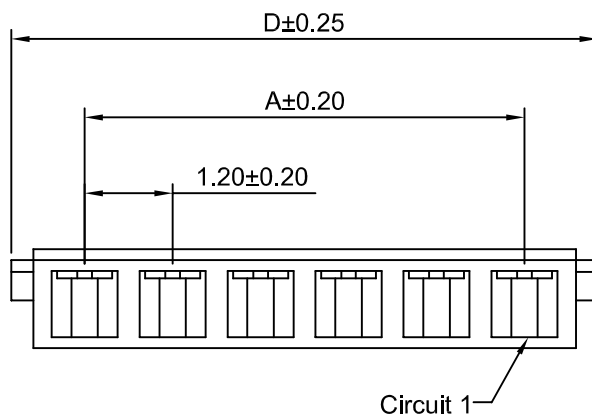
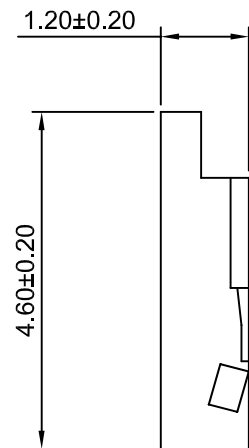
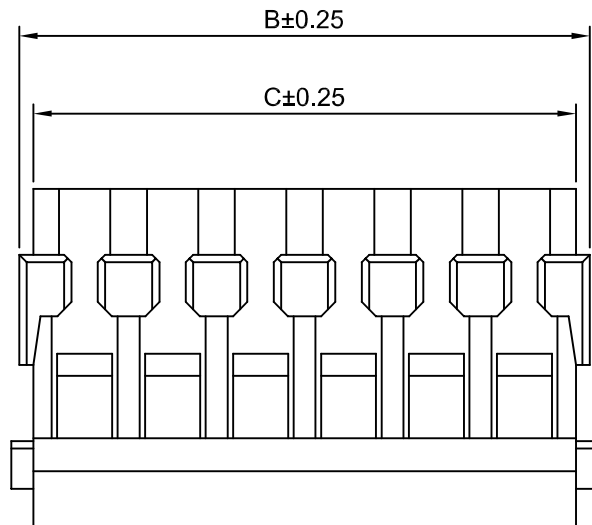

Ordering Information & Dimensions

Circuits	Dimensions(mm)			
	A	B	C	D
2P	1.20	2.98	2.60	3.20
3P	2.40	4.18	3.80	4.40
4P	3.60	5.38	5.00	5.60
5P	4.80	6.58	6.20	6.80
6P	6.00	7.78	7.40	8.00

SPECIFICATIONS:
 Current Rating: 2A AC,DC
 Voltage Rating: 50V AC,DC
 Temperature Range: -25°C ~ +85°C
 Contact Resistance: 20mΩ Max.
 Insulation Resistance: 100MΩ Min.
 Withstanding Voltage: 500V AC/minute
 Material: PBT UL94V-0(Natural)

HDGC 深圳市华德共创科技有限公司
 Shenzhen Huade co-create Technology Co.,LTD
 TEL : 0755-27129737 FAX : 0755-29940187

-TOLERANCES- UNLESS OTHERWISE SPECIFIED 公差参数表						TITLE: 产品名称 : 1.20mm Pitch Housing			
X.X	±0.30	X.X°	±3°	APPD: 核准:	XIE	PART NO: 产品编号 : HDGC1201HC-XP			
X.XX	±0.30	X.XX°	±2°	CHECK: 校对:	WANG	DATE	SCALE	UNIT	CODE NUMBER
X.XXX	±0.10	X.XXX°	±1°	DRAW: 绘图:	WANG	2013-10-25	10:1	mm	A008

修订 REV	标记 MARK	修改摘要 REVISION DESCRIPTION	签名 SIGNATURE	日期 DATE
AO		NEW RELEASE	WANG	2013-10-25

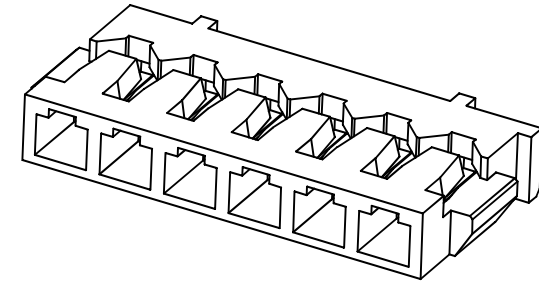
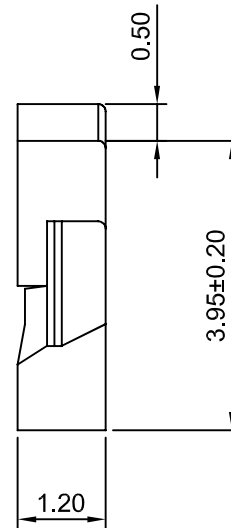
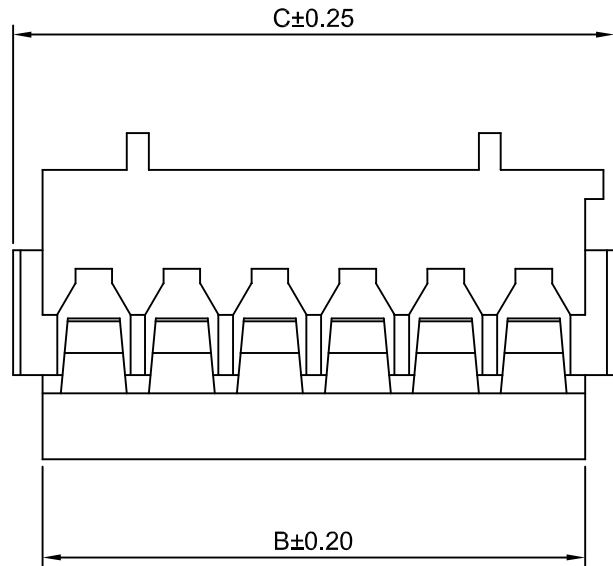
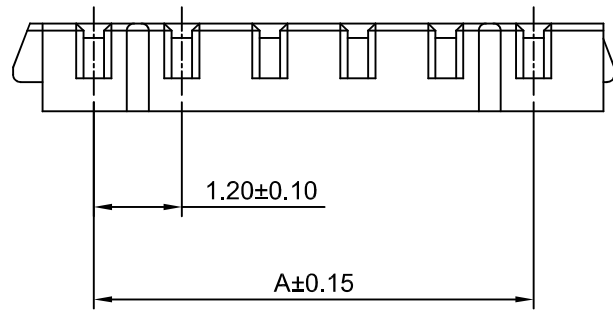

Ordering Information & Dimensions

Circuits	Dimensions(mm)			Circuits	Dimensions(mm)		
	A	B	C		A	B	C
2P	1.20	2.60	3.40	5P	4.80	6.20	7.00
3P	2.40	3.80	4.60	6P	6.00	7.40	8.20
4P	3.60	5.00	5.80				

SPECIFICATIONS:

Current Rating: 2.5A AC,DC
Voltage Rating: 50V AC,DC
Temperature Range: -25°C ~ +85°C
Contact Resistance: 20mΩ Max.
Insulation Resistance: ≥100MΩ Min.
Withstanding Voltage: 500V AC/minute
Material: PBT , UL94V-0(gray)



深圳市华德共创科技有限公司

Shenzhen Huade co-create Technology Co.,LTD
TEL : 0755-27129737 FAX : 0755-29940187

-TOLERANCES- UNLESS OTHERWISE SPECIFIED 公差参数表						TITLE: 产品名称 : 1.20mm Pitch Housing			
X.X	±0.30	X.X°	±3°	APPD: 核准:	XIE	PART NO: 产品编号 : HDGC1201HD-XP			
X.XX	±0.30	X.XX°	±2°	CHECK: 校对:	WANG	DATE	SCALE	UNIT	CODE NUMBER
X.XXX	±0.10	X.XXX°	±1°	DRAW: 绘图:	WANG	2013-10-25	10:1	mm	A008

修订 REV	标记 MARK	修改摘要 REVISION DESCRIPTION	签名 SIGNATURE	日期 DATE
AO		NEW RELEASE	WANG	2011-03-21

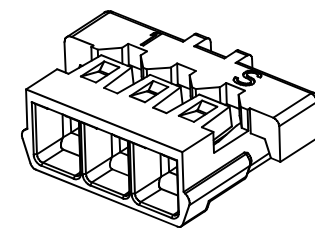
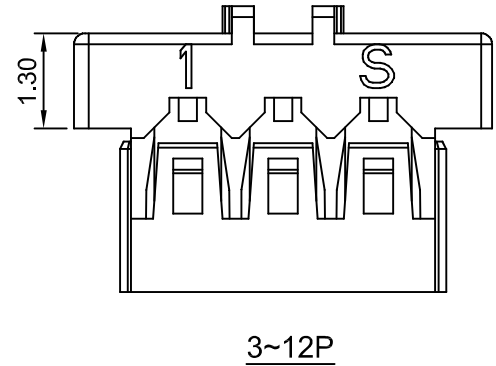
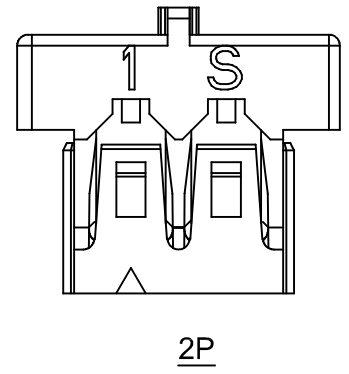
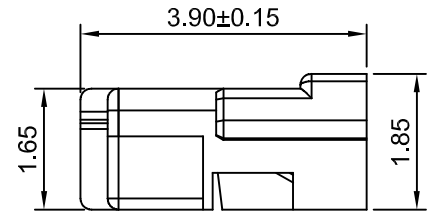
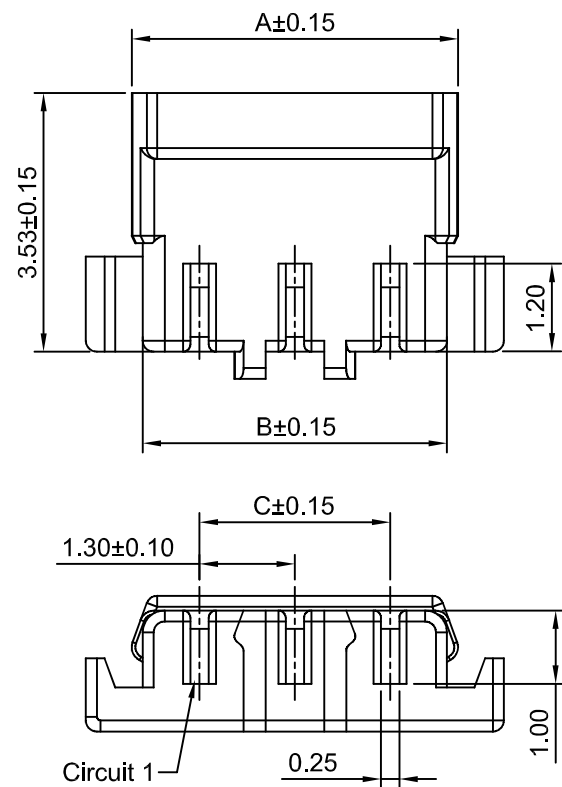

Ordering Information:
 HDGC1201HG-XP - ***
 1 2
 1.Part No.
 2.Color:
 (blank) - White
 BK - Black
 GY - Gray

Ordering Information & Dimensions

Circuits	Dimensions(mm)			Circuits	Dimensions(mm)		
	A	B	C		A	B	C
2P	3.15	2.85	1.30	8P	10.95	10.65	9.10
3P	4.45	4.15	2.60	9P	12.25	11.95	10.40
4P	5.75	5.45	3.90	10P	13.55	13.25	11.70
5P	7.05	6.75	5.20	11P	14.85	14.55	13.00
6P	8.35	8.05	6.50	12P	16.15	15.85	14.30
7P	9.65	9.35	7.80				

SPECIFICATIONS:
 Current Rating: 3A AC,DC
 Voltage Rating: 30V AC,DC
 Temperature Range: -25°C ~ +85°C
 Contact Resistance: 20MΩ Max
 Insulation Resistance: 100MΩ Min
 Withstanding Voltage: 500V AC/minute
 Material:Nylon 66,UL94V-0(White)

深圳市华德共创科技有限公司
 Shenzhen Huade co-create Technology Co.,LTD
 TEL : 0755-27129737 FAX : 0755-29940187

-TOLERANCES- UNLESS OTHERWISE SPECIFIED 公差参数表					TITLE: 产品名称 : 1.20mm Pitch Housing			
X.X	±0.30	X.X°	±3°	APPD: 核准 : XIE	PART NO: 产品编号 : HDGC1201HG-XP			
X.XX	±0.30	X.XX°	±2°	CHECK: 校对 : WANG	DATE	SCALE	UNIT	CODE NUMBER
X.XXX	±0.10	X.XXX°	±1°	DRAW: 绘图 : WANG	2011-03-21	10:1	mm	A008

修订 REV	标记 MARK	修改摘要 REVISION DESCRIPTION	签名 SIGNATURE	日期 DATE
AO		NEW RELEASE	WANG	2011-03-21

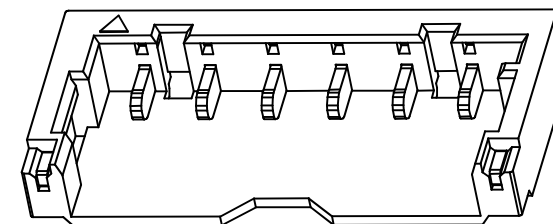
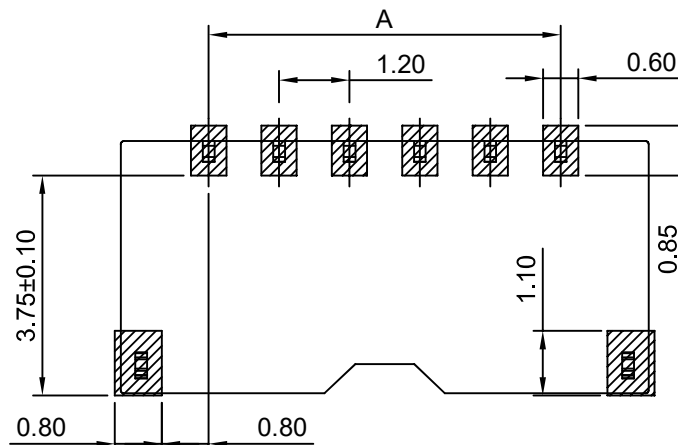
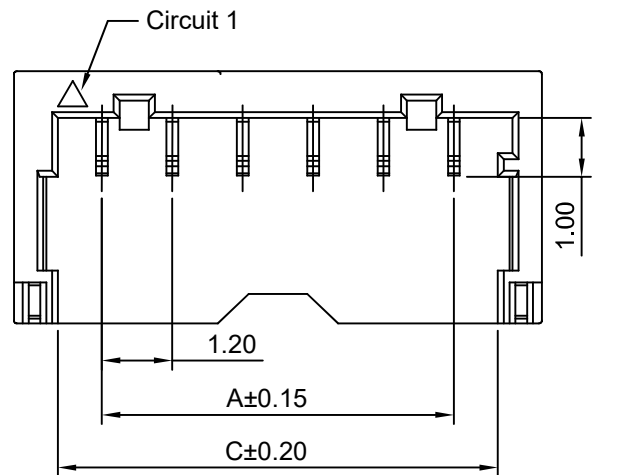

RECOMMENDED PCB LAYOUT
GENERAL TOLERANCE ±0.05

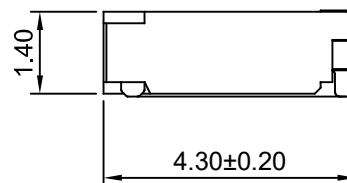
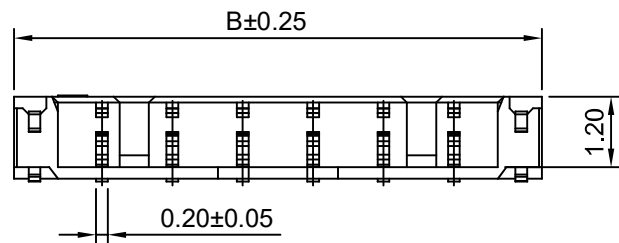

Ordering Information & Dimensions

Circuits	Dimensions(mm)			Circuits	Dimensions(mm)		
	A	B	C		A	B	C
2P	1.20	4.20	2.70	6P	6.00	9.00	7.50
3P	2.40	5.40	3.90	7P	7.20	10.20	8.70
4P	3.60	6.60	5.10	8P	8.40	11.40	9.90
5P	4.80	7.80	6.30				

SPECIFICATIONS:

Current Rating: 2A AC,DC
Voltage Rating: 50V AC,DC
Temperature Range: -25°C ~ +85°C
Contact Resistance: ≤10MΩ Max
Insulation Resistance: 100MΩ Min
Withstanding Voltage: 500V AC/minute
Pin Material: Phosphor Bronze/Tin over Nickel
Material: Nylon9T,UL 94V-0(Natural)



深圳市华德共创科技有限公司

Shenzhen Huade co-create Technology Co.,LTD

TEL : 0755-27129737 FAX : 0755-29940187

-TOLERANCES- UNLESS OTHERWISE SPECIFIED 公差参数表						TITLE: 1.20mm Pitch 产品名称: 90° Wafer			
X.X	±0.30	X.X°	±3°	APPD: 核准:	XIE	PART NO: 产品编号: HDGC1201WRD-S-XP			
X.XX	±0.30	X.XX°	±2°	CHECK: 校对:	WANG	DATE	SCALE	UNIT	CODE NUMBER
X.XXX	±0.10	X.XXX°	±1°	DRAW: 绘图:	WANG	2011-03-21	8:1	mm	A008

修订 REV	标记 MARK	修改摘要 REVISION DESCRIPTION	签名 SIGNATURE	日期 DATE
AO		NEW RELEASE	WANG	2018-05-30

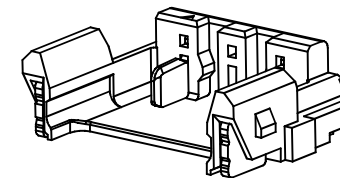

Ordering Information:

HDGC1201WRG-S-XP-A - $\frac{***}{1}$ - $\frac{***}{2}$ - $\frac{***}{3}$

- Part No.
- Material:
(blank) - Nylon 4T ,UL94V-0
HF - Nylon 4T ,UL94V-0, Halogen Free
- Color:
(blank) - White
BK - Black

Ordering Information & Dimensions

Circuits	Dimensions(mm)			Circuits	Dimensions(mm)		
	A	B	C		A	B	C
3P	2.60	5.70	5.00	9P	10.40	13.50	12.80
5P	5.20	8.30	7.60	11P	13.00	16.10	15.40
7P	7.80	10.90	10.20				

SPECIFICATIONS:

Current Rating: 3A AC,DC
Voltage Rating: 30V AC,DC
Temperature Range: -25°C ~ +85°C
Contact Resistance: 20MΩ Max
Insulation Resistance: 100MΩ Min
Withstanding Voltage: 500V AC/minute
Pin Material: High conductivity copper/Gold over Nickel
Material: Nylon 4T ,UL94V-0(White)

P.C.B LAYOUT

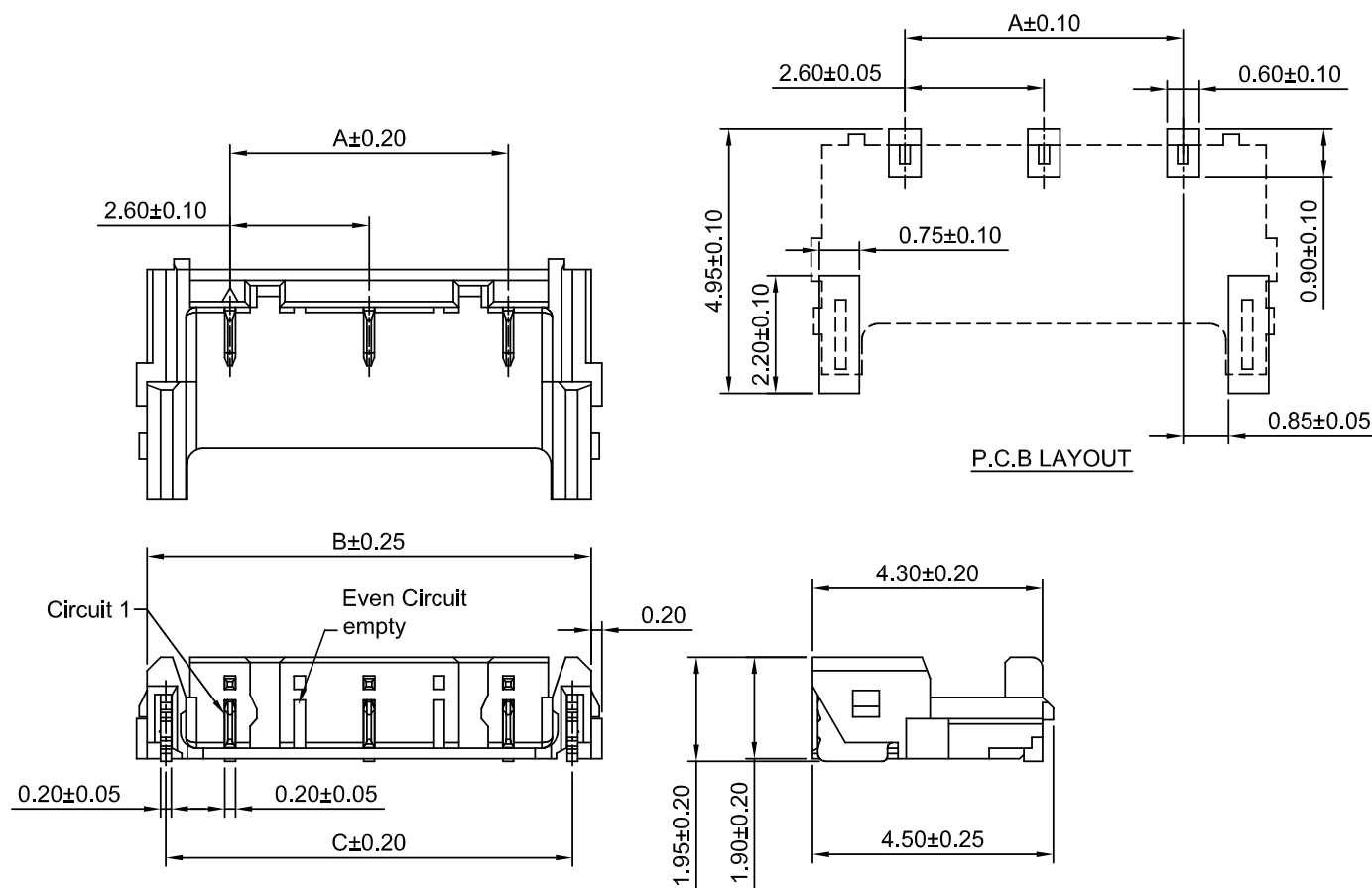

深圳市华德共创科技有限公司

Shenzhen Huade co-create Technology Co.,LTD

TEL : 0755-27129737 FAX : 0755-29940187

-TOLERANCES- UNLESS OTHERWISE SPECIFIED 公差参数表						TITLE: 1.20mm Pitch 产品名称: 90° Wafer			
X.X	±0.30	X.X°	±3°	APPD: 核准:	XIE	PART NO: 产品编号: HDGC1201WRG-S-XP-A			
X.XX	±0.30	X.XX°	±2°	CHECK: 校对:	WANG	DATE	SCALE	UNIT	CODE NUMBER
X.XXX	±0.10	X.XXX°	±1°	DRAW: 绘图:	WANG	2018-05-30	8:1	mm	A008

修订 REV	标记 MARK	修改摘要 REVISION DESCRIPTION	签名 SIGNATURE	日期 DATE
AO		NEW RELEASE	WANG	2018-05-30

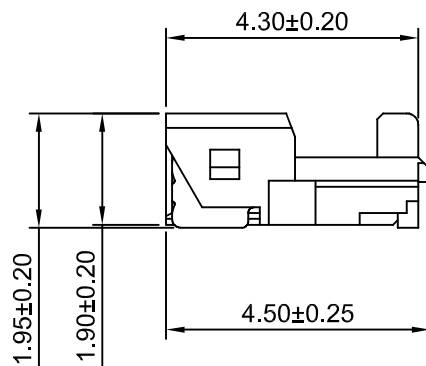
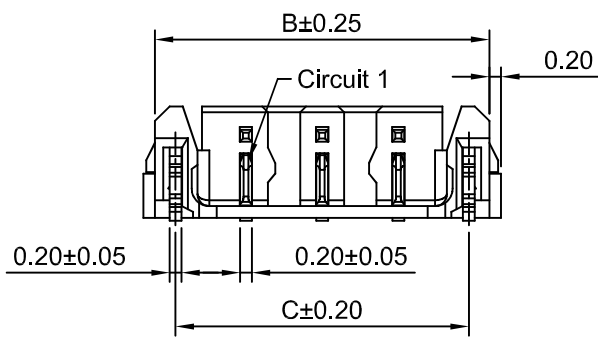
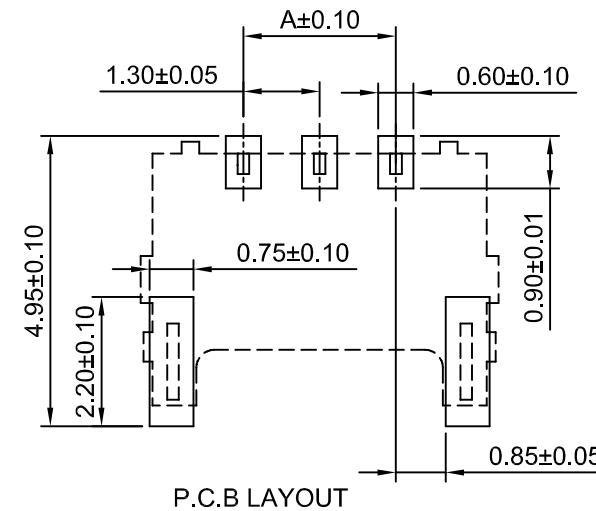
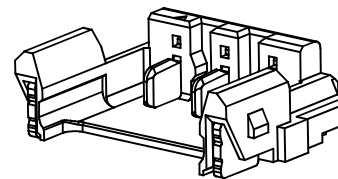
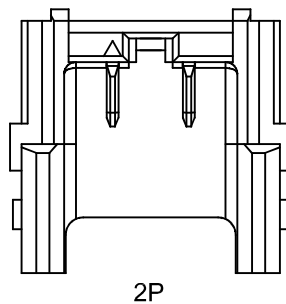
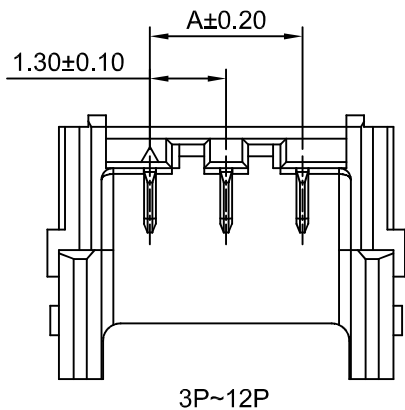

Ordering Information & Dimensions

Circuits	Dimensions(mm)			Circuits	Dimensions(mm)		
	A	B	C		A	B	C
2P	1.30	4.40	3.70	8P	9.10	12.20	11.50
3P	2.60	5.70	5.00	9P	10.40	13.50	12.80
4P	3.90	7.00	6.30	10P	11.70	14.80	14.10
5P	5.20	8.30	7.60	11P	13.00	16.10	15.40
6P	6.50	9.60	8.90	12P	14.30	17.40	16.70
7P	7.80	10.90	10.20				

Ordering Information:

HDGC1201WRG-S-XP - *** - ***
1 2 3

1.Part No.

2.Material:

(blank) - Nylon 4T ,UL94V-0

HF - Nylon 4T ,UL94V-0, Halogen Free

3.Color:

(blank) - White

BK - Black

SPECIFICATIONS:

Current Rating: 3A AC,DC

Voltage Rating: 30V AC,DC

Temperature Range: -25°C ~ +85°C

Contact Resistance: 20MΩ Max

Insulation Resistance: 100MΩ Min

Withstanding Voltage: 500V AC/minute

Pin Material: High conductivity copper/Gold over Nickel

Material: Nylon 4T ,UL94V-0(White)



深圳市华德共创科技有限公司

Shenzhen Huade co-create Technology Co.,LTD

TEL : 0755-27129737 FAX : 0755-29940187

-TOLERANCES-
UNLESS OTHERWISE SPECIFIED
公差参数表

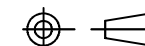

TITLE: 1.20mm Pitch
产品名称: 90° Wafer

X.X ±0.30 X.X° ±3° APPD: 核准: XIE

PART NO: HDGC1201WRG-S-XP
产品编号:

X.XX ±0.30 X.XX° ±2° CHECK: 校对: WANG

DATE SCALE UNIT CODE NUMBER

X.XXX ±0.10 X.XXX° ±1° DRAW: 绘图: WANG

2018-05-30 8:1 mm A008