

修订 REV	标记 MARK	修改摘要 REVISION DESCRIPTION	签名 SIGNATURE	日期 DATE
AO		NEW RELEASE	WANG	2011-06-08

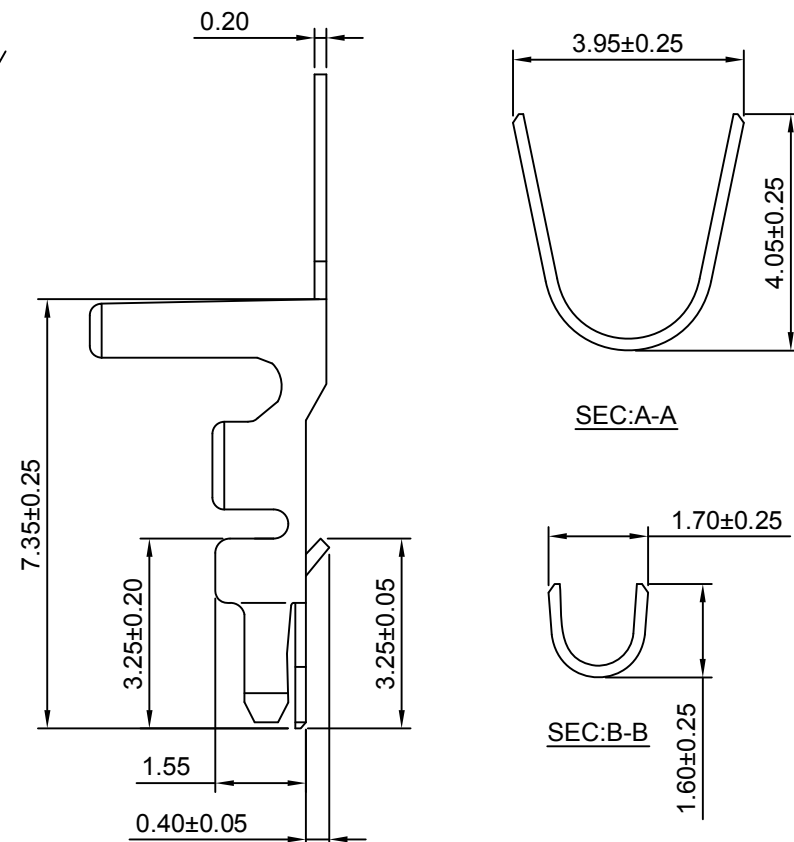
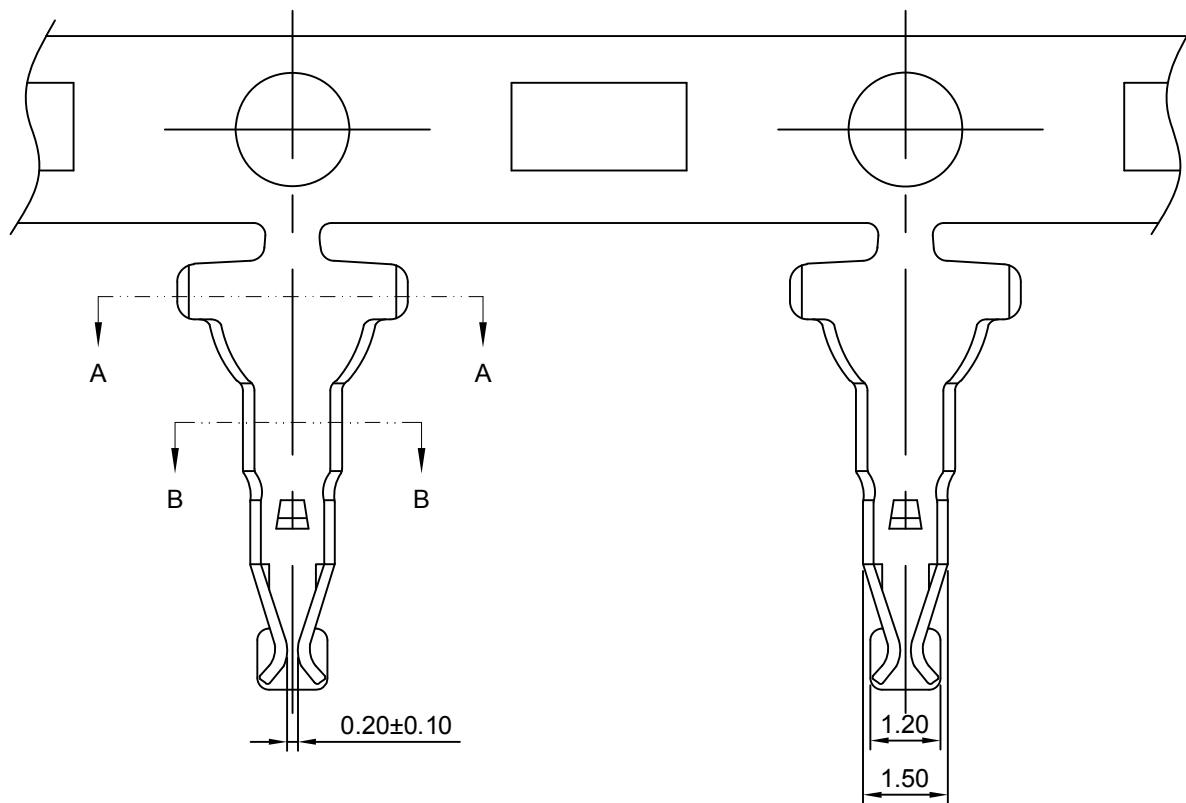

Ordering information & Specifications

Unit:mm

Part No	Wire Range	Insultion O.D.	Material	Finish	Qty/reel
HDGC4001-TP	AWG#18-#22	3.00mm(max)	Phosphor Bronze	Tin over Nickel	5,000 PCS
HDGC4001-GP	AWG#18-#22	3.00mm(max)	Phosphor Bronze	Gold over Nickel	5,000 PCS

Optional Gold plating available but MOQ requested



深圳市华德共创科技有限公司

SHENZHEN HUADE CO-CREATE TECHNOLOGY CO.,LTD

TEL : 0755-27129737 FAX : 0755-29940187

-TOLERANCES- UNLESS OTHERWISE SPECIFIED 公差参数表					TITLE: 4.00mm Pitch 产品名称: Crimp Terminal				
X.X	±0.30	X.X°	±3°	APPD: 核准:	XIE				
X.XX	±0.30	X.XX°	±2°	CHECK: 校对:	WANG	DATE	SCALE	UNIT	CODE NUMBER
X.XXX	±0.10	X.XXX°	±1°	DRAW: 绘图:	WANG	2011-06-08	8:1	mm	A008

修订 REV	标记 MARK	修改摘要 REVISION DESCRIPTION	签名 SIGNATURE	日期 DATE
AO		NEW RELEASE	WANG	2011-06-08

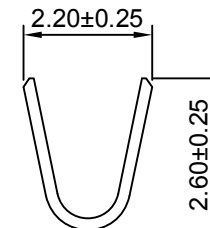
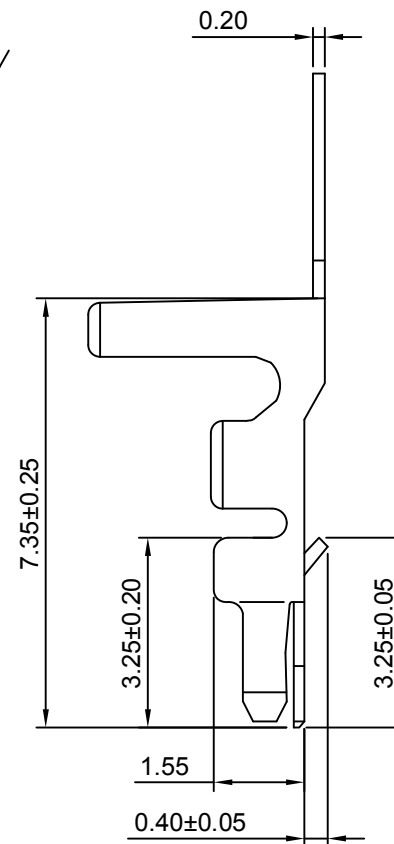
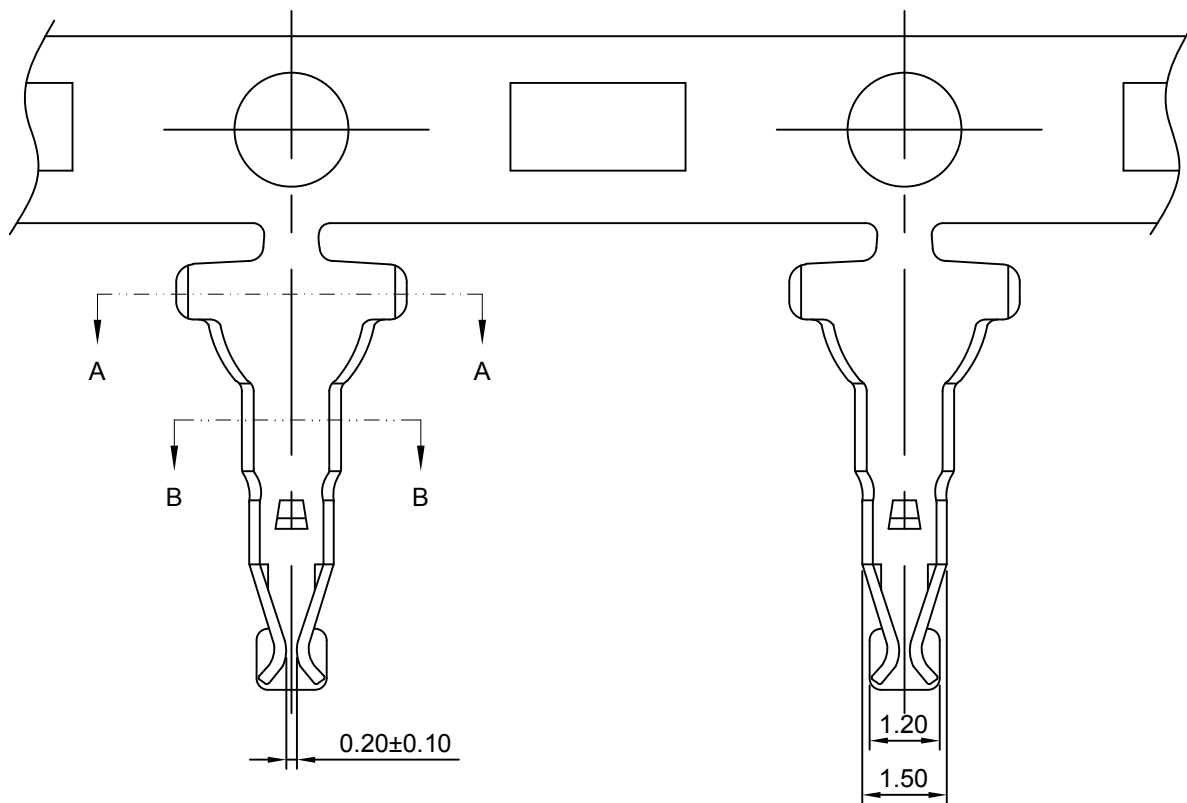

SEC:A-A

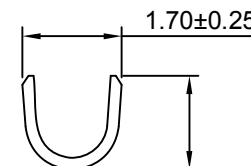

SEC:B-B

Ordering information & Specifications

Unit:mm

Part No	Wire Range	Insultion O.D.	Material	Finish	Qty/reel
HDGC4001-TP-L	AWG#22-#28	1.60mm(max)	Phosphor Bronze	Tin over Nickel	8,000 PCS
HDGC4001-GP-L	AWG#22-#28	1.60mm(max)	Phosphor Bronze	Gold over Nickel	8,000 PCS

Optional Gold plating available but MOQ requested



深圳市华德共创科技有限公司

SHENZHEN HUADE CO-CREATE TECHNOLOGY CO.,LTD

TEL : 0755-27129737 FAX : 0755-29940187

-TOLERANCES- UNLESS OTHERWISE SPECIFIED 公差参数表					TITLE: 4.00mm Pitch 产品名称: Crimp Terminal				
X.X	± 0.30	X.X°	$\pm 3^\circ$	APPD: 核准:	XIE				
X.XX	± 0.30	X.XX°	$\pm 2^\circ$	CHECK: 校对:	WANG	DATE	SCALE	UNIT	CODE NUMBER
X.XXX	± 0.10	X.XXX°	$\pm 1^\circ$	DRAW: 绘图:	WANG	2011-06-08	8:1	mm	A008

PART NO: HDGC4001-T-L
产品编号:

修订 REV	标记 MARK	修改摘要 REVISION DESCRIPTION	签名 SIGNATURE	日期 DATE
AO		NEW RELEASE	WANG	2011-06-08

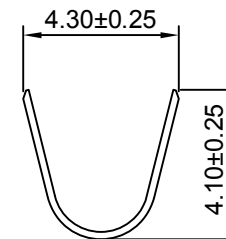
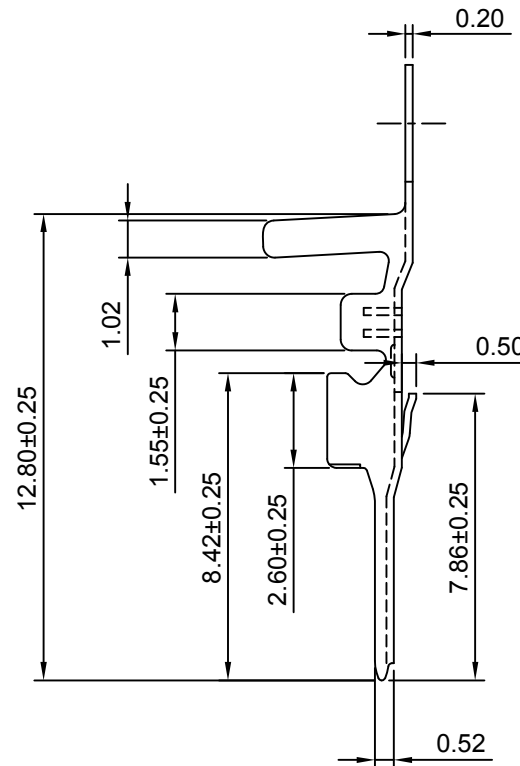
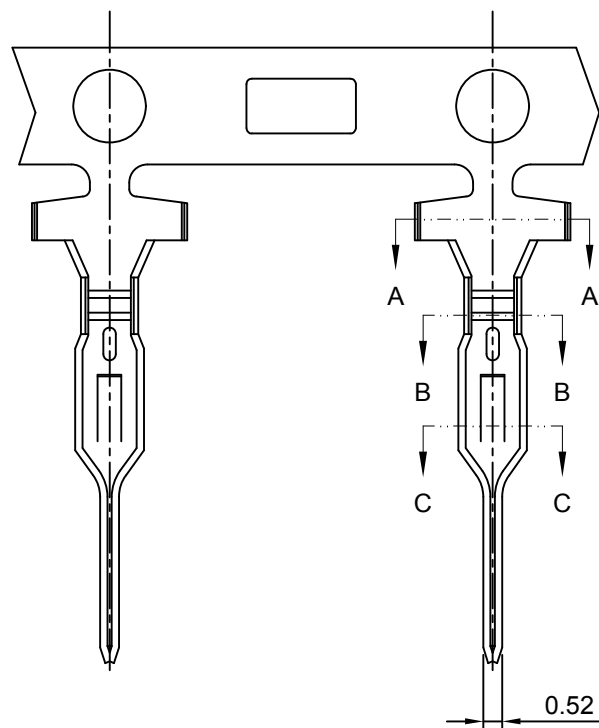

SEC:A-A

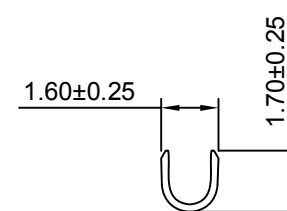

SEC:B-B

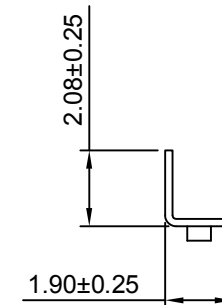

SEC:C-C

Ordering information & Specifications

Unit:mm

Part No	Wire Range	Insultion O.D.	Material	Finish	Qty/reel
HDGC4001M-TP	AWG#22-#28	2.40mm(max)	Phosphor Bronze	Tin over Nickel	5,000 PCS
HDGC4001M-GP	AWG#22-#28	2.40mm(max)	Phosphor Bronze	Gold over Nickel	5,000 PCS

Optional Gold plating available but MOQ requested



深圳市华德共创科技有限公司

SHENZHEN HUADE CO-CREATE TECHNOLOGY CO.,LTD

TEL : 0755-27129737 FAX : 0755-29940187

-TOLERANCES- UNLESS OTHERWISE SPECIFIED 公差参数表						TITLE: 4.00mm Pitch 产品名称: Crimp Terminal			
X.X	±0.30	X.X°	±3°	APPD: 核准:	XIE	PART NO: 产品编号: HDGC4001M-T			
X.XX	±0.30	X.XX°	±2°	CHECK: 校对:	WANG	DATE	SCALE	UNIT	CODE NUMBER
X.XXX	±0.10	X.XXX°	±1°	DRAW: 绘图:	WANG	2011-06-08	5:1	mm	A008

修订 REV	标记 MARK	修改摘要 REVISION DESCRIPTION	签名 SIGNATURE	日期 DATE
AO		NEW RELEASE	WANG	2011-06-08

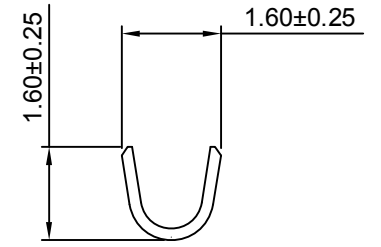
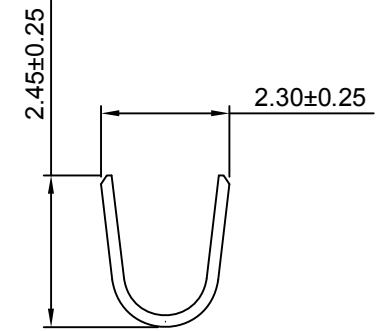
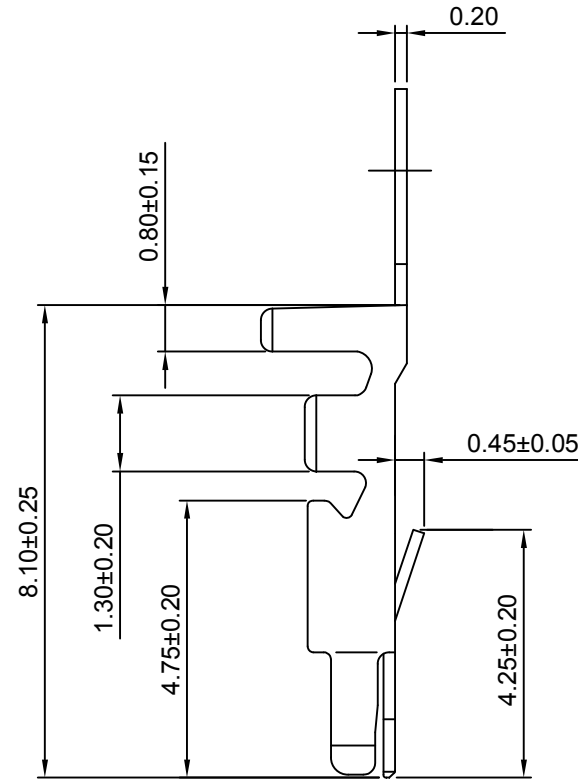
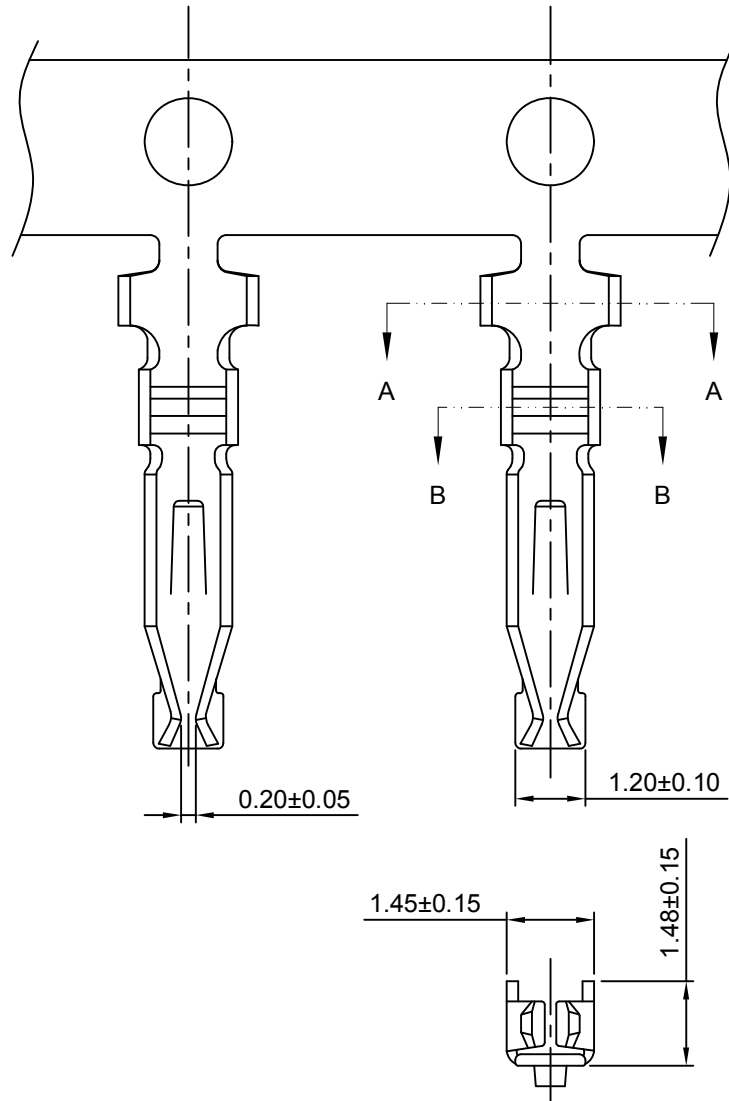

Ordering information & Specifications

Unit:mm

Part No	Wire Range	Insultion O.D.	Material	Finish	Qty/reel
HDGC4001A-TP	AWG#24-#28	1.60mm(max)	Phosphor Bronze	Tin over Nickel	5,000 PCS
HDGC4001A-GP	AWG#24-#28	1.60mm(max)	Phosphor Bronze	Gold over Nickel	5,000 PCS

Optional Gold plating available but MOQ requested



深圳市华德共创科技有限公司

SHENZHEN HUADE CO-CREATE TECHNOLOGY CO.,LTD

TEL : 0755-27129737 FAX : 0755-29940187

-TOLERANCES- UNLESS OTHERWISE SPECIFIED 公差参数表					TITLE: 4.00mm Pitch 产品名称: Crimp Terminal			
X.X	±0.30	X.X°	±3°	APPD: 核准: XIE	PART NO: 产品编号: HDGC4001A-T			
X.XX	±0.30	X.XX°	±2°	CHECK: 校对: WANG	DATE	SCALE	UNIT	CODE NUMBER
X.XXX	±0.10	X.XXX°	±1°	DRAW: 绘图: WANG	2011-06-08	1:1	mm	A008

修订 REV	标记 MARK	修改摘要 REVISION DESCRIPTION	签名 SIGNATURE	日期 DATE
AO		NEW RELEASE	WANG	2011-06-08

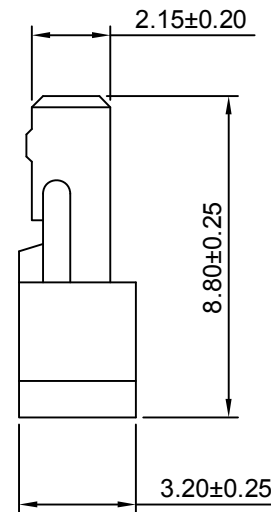
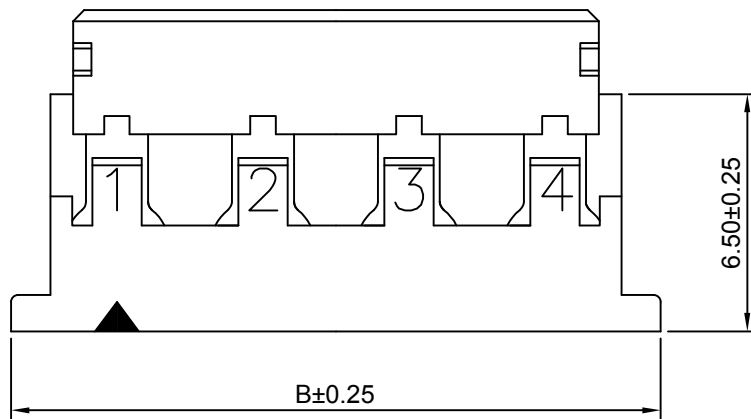
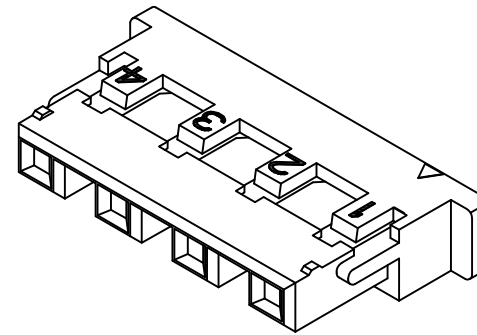
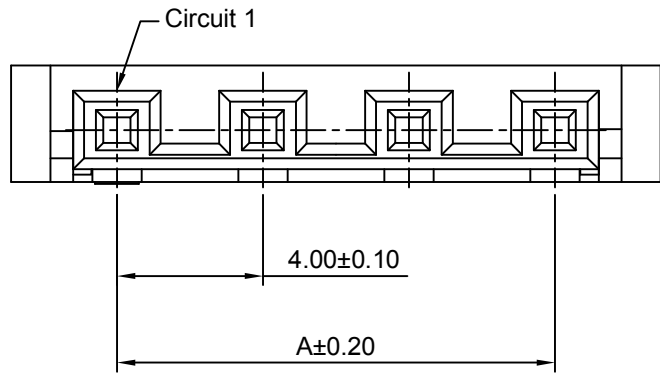

SPECIFICATIONS:

Current Rating: 1A AC,DC
Voltage Rating: 600V AC,DC
Temperature Range: -25°C ~ +85°C
Contact Resistance: 10mΩ Max
Insulation Resistance: 1000MΩ Min
Withstanding Voltage: 1800V AC/minute
Material: Nylon 66 ,UL94V-0(White)

Ordering Information & Dimensions

Circuits	Dimensions(mm)		Circuits	Dimensions(mm)	
	A	B		A	B
2P	4.00	9.80	4P	12.00	17.80
3P	8.00	13.80	5P	16.00	21.80



深圳市华德共创科技有限公司

SHENZHEN HUADE CO-CREATE TECHNOLOGY CO.,LTD

TEL : 0755-27129737 FAX : 0755-29940187

-TOLERANCES- UNLESS OTHERWISE SPECIFIED 公差参数表						TITLE: 4.00mm Pitch Housing 产品名称: 4.00mm Pitch Housing			
X.X	±0.30	X.X°	±3°	APPD: 核准:	XIE	PART NO: 产品编号: HDGC4001H-XP			
X.XX	±0.30	X.XX°	±2°	CHECK: 校对:	WANG	DATE	SCALE	UNIT	CODE NUMBER
X.XXX	±0.10	X.XXX°	±1°	DRAW: 绘图:	WANG	2011-06-08	5:1	mm	A008

修订 REV	标记 MARK	修改摘要 REVISION DESCRIPTION	签名 SIGNATURE	日期 DATE
AO		NEW RELEASE	WANG	2011-06-08

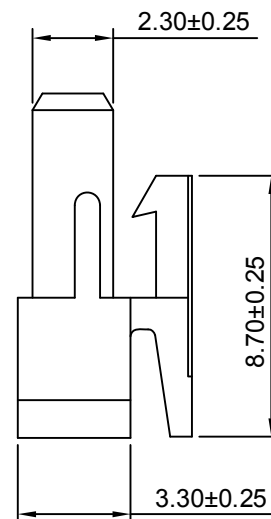
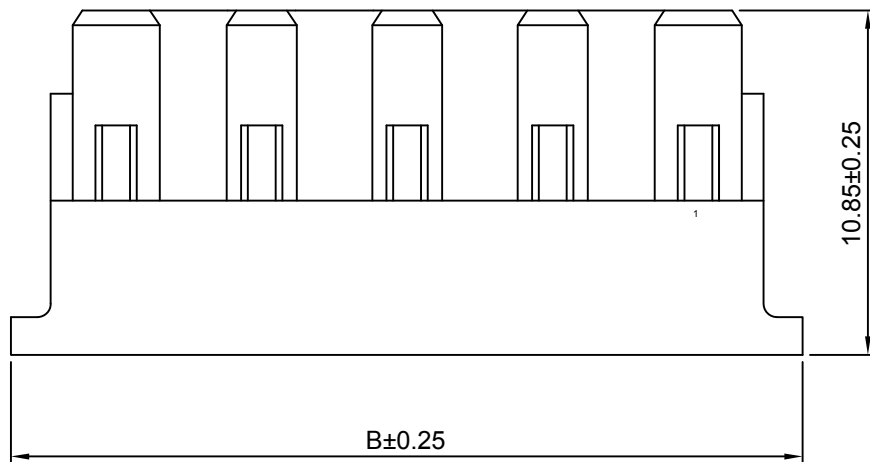
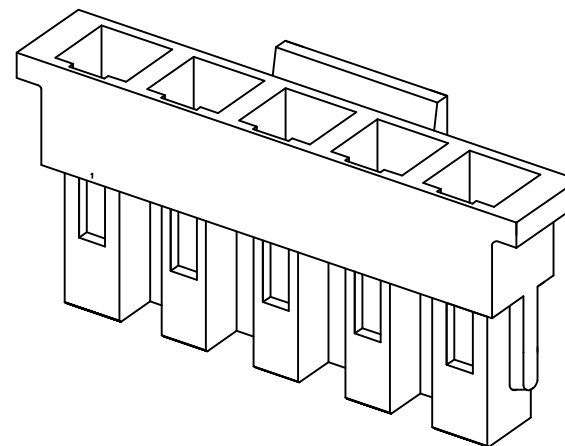
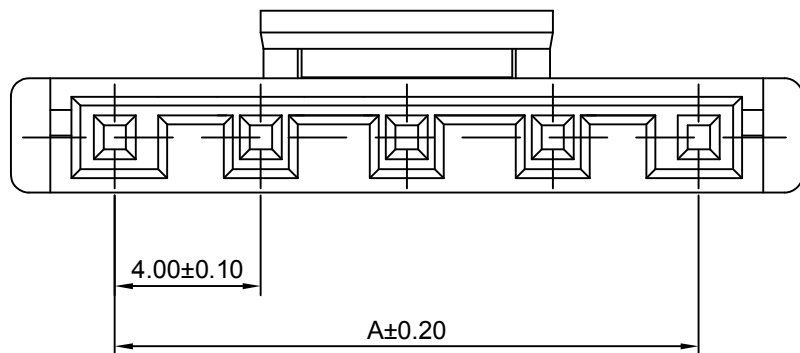

SPECIFICATIONS:

Current Rating: 1A AC,DC
Voltage Rating: 600V AC,DC
Temperature Range: -25°C ~ +85°C
Contact Resistance: 10mΩ Max
Insulation Resistance: 1000MΩ Min
Withstanding Voltage: 1800V AC/minute
Material: Nylon 66 ,UL94V-0

Ordering Information & Dimensions

Circuits	Dimensions(mm)		Circuits	Dimensions(mm)	
	A	B		A	B
2P	4.00	10.35	4P	12.00	18.35
3P	8.00	14.35	5P	16.00	22.35



深圳市华德共创科技有限公司

SHENZHEN HUADE CO-CREATE TECHNOLOGY CO.,LTD

TEL : 0755-27129737 FAX : 0755-29940187

-TOLERANCES-
UNLESS OTHERWISE SPECIFIED
公差参数表

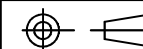

TITLE: 4.00mm Pitch
产品名称: Housing

X.X ±0.30 X.X° ±3°

APPD: 核准: XIE

PART NO: HDGC4001HA-XP
产品编号:

X.XX ±0.30 X.XX° ±2°

CHECK: 校对: WANG

DATE SCALE UNIT CODE NUMBER

X.XXX ±0.10 X.XXX° ±1°

DRAW: 绘图: WANG

2011-06-08 5:1 mm A008

修订 REV	标记 MARK	修改摘要 REVISION DESCRIPTION	签名 SIGNATURE	日期 DATE
AO		NEW RELEASE	WANG	2011-06-08

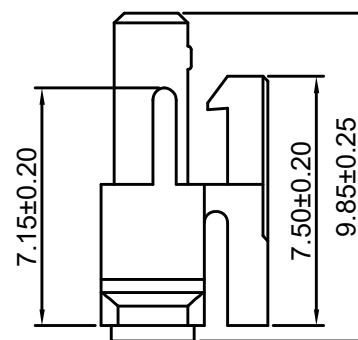
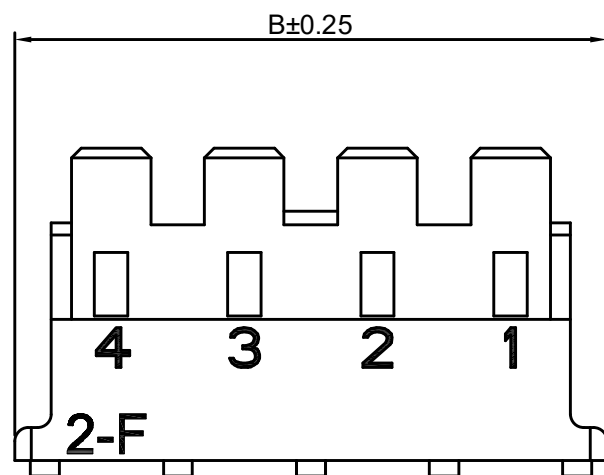
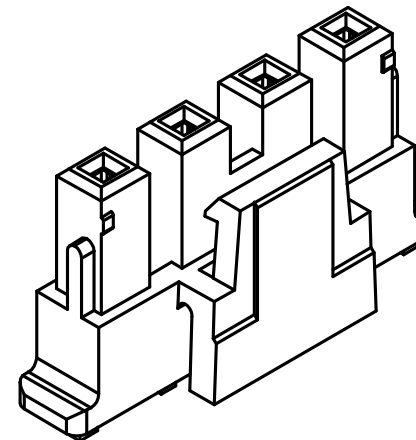
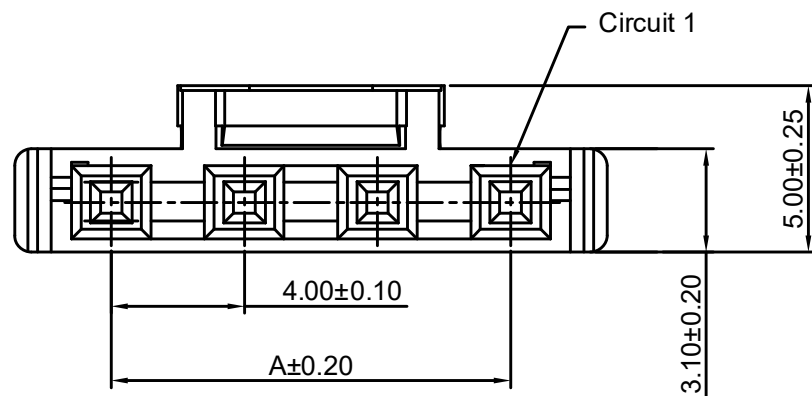

SPECIFICATIONS:

Current Rating: 1A AC,DC
Voltage Rating: 600V AC,DC
Temperature Range: -25°C ~ +85°C
Contact Resistance: 10mΩ Max
Insulation Resistance: 1000MΩ Min
Withstanding Voltage: 1800V AC/minute
Material: Nylon 66 ,UL94V-0

Ordering Information & Dimensions

Circuits	Dimensions(mm)		Circuits	Dimensions(mm)	
	A	B		A	B
2P	4.00	10.35	4P	12.00	18.35
3P	8.00	14.35	5P	16.00	22.35

HDGC 深圳市华德共创科技有限公司
SHENZHEN HUADE CO-CREATE TECHNOLOGY CO.,LTD
TEL : 0755-27129737 FAX : 0755-29940187

-TOLERANCES- UNLESS OTHERWISE SPECIFIED 公差参数表						TITLE: 产品名称: 4.00mm Pitch Housing			
X.X	±0.30	X.X°	±3°	APPD: 核准:	XIE	PART NO: 产品编号: HDGC4001HB-XP			
X.XX	±0.30	X.XX°	±2°	CHECK: 校对:	WANG	DATE	SCALE	UNIT	CODE NUMBER
X.XXX	±0.10	X.XXX°	±1°	DRAW: 绘图:	WANG	2011-06-08	5:1	mm	A008

修订 REV	标记 MARK	修改摘要 REVISION DESCRIPTION	签名 SIGNATURE	日期 DATE
AO		NEW RELEASE	WANG	2011-06-08

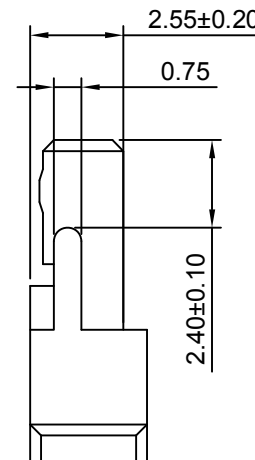
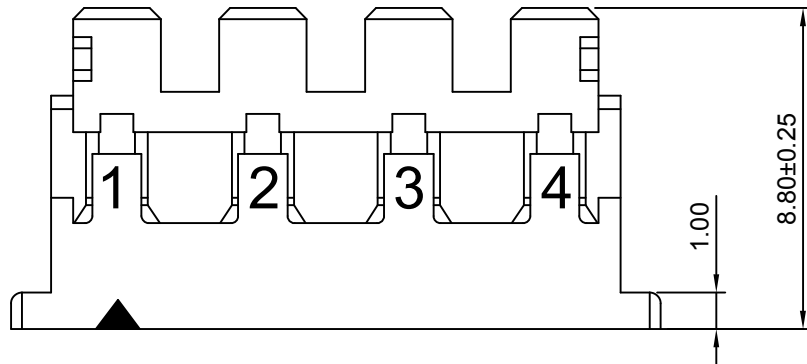
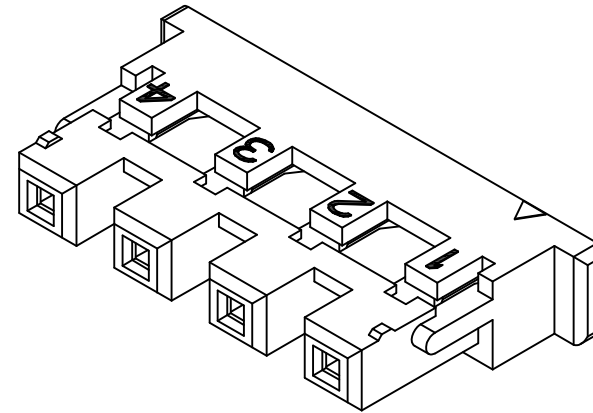
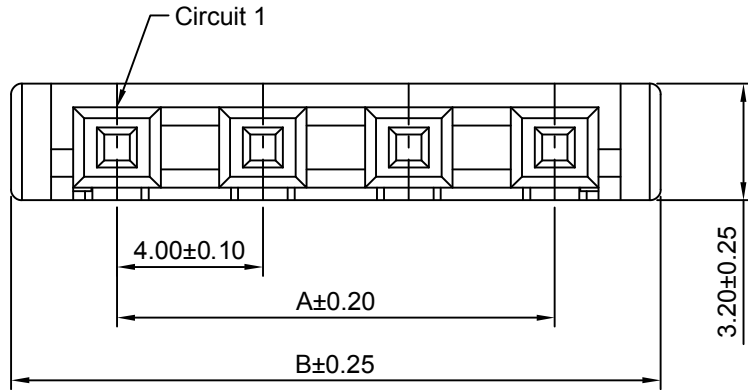

SPECIFICATIONS:

Current Rating: 1A AC,DC
Voltage Rating: 600V AC,DC
Temperature Range: -25°C ~ +85°C
Contact Resistance: 10mΩ Max
Insulation Resistance: 1000MΩ Min
Withstanding Voltage: 1800V AC/minute
Material: Nylon 66 ,UL94V-0(White)

Ordering Information & Dimensions

Circuits	Dimensions(mm)		Circuits	Dimensions(mm)	
	A	B		A	B
2P	4.00	9.80	4P	12.00	17.80
3P	8.00	13.80	5P	16.00	21.80



深圳市华德共创科技有限公司

SHENZHEN HUADE CO-CREATE TECHNOLOGY CO.,LTD

TEL : 0755-27129737 FAX : 0755-29940187

-TOLERANCES- UNLESS OTHERWISE SPECIFIED 公差参数表						TITLE: 产品名称 : 4.00mm Pitch Housing			
X.X	±0.30	X.X°	±3°	APPD: 核准 :	XIE	PART NO: 产品编号 : HDGC4001HC-XP			
X.XX	±0.30	X.XX°	±2°	CHECK: 校对 :	WANG	DATE	SCALE	UNIT	CODE NUMBER
X.XXX	±0.10	X.XXX°	±1°	DRAW: 绘图 :	WANG	2011-06-08	5:1	mm	A008

修订 REV	标记 MARK	修改摘要 REVISION DESCRIPTION	签名 SIGNATURE	日期 DATE
AO		NEW RELEASE	WANG	2012-03-21

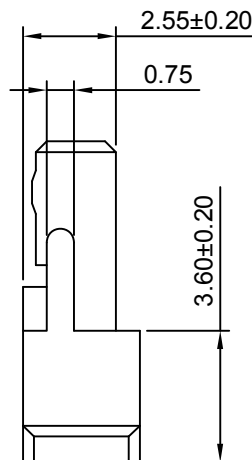
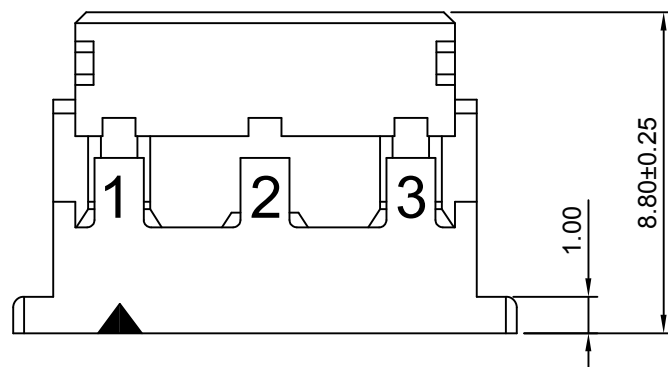
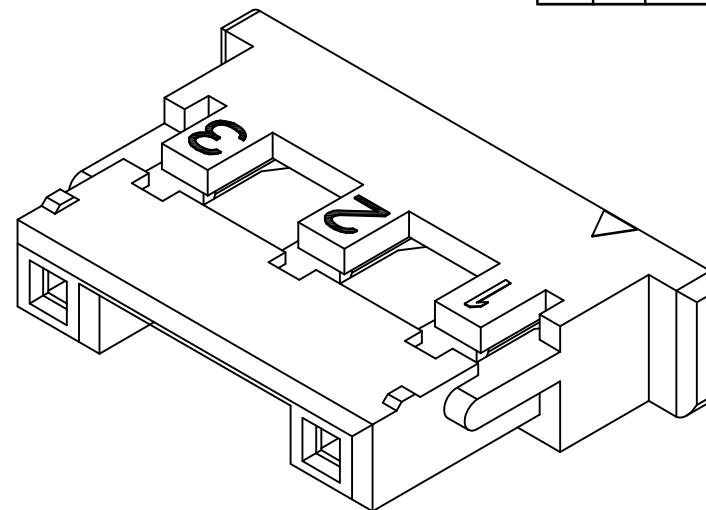
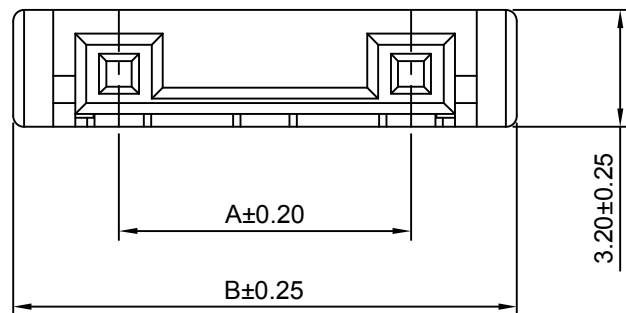

SPECIFICATIONS:

Current Rating: 1A AC,DC
Voltage Rating: 600V AC,DC
Temperature Range: -25°C ~ +85°C
Contact Resistance: 10mΩ Max
Insulation Resistance: 1000MΩ Min
Withstanding Voltage: 1800V AC/minute
Material: Nylon 66 ,UL94V-0(White)

Ordering Information & Dimensions

Circuits	Dimensions(mm)		Circuits	Dimensions(mm)	
	A	B		A	B
3P	8.00	13.80	5P	16.00	21.80



深圳市华德共创科技有限公司

SHENZHEN HUADE CO-CREATE TECHNOLOGY CO.,LTD

TEL : 0755-27129737 FAX : 0755-29940187

-TOLERANCES- UNLESS OTHERWISE SPECIFIED 公差参数表						TITLE: 4.00mm Pitch 产品名称: Housing			
X.X	±0.30	X.X°	±3°	APPD: 核准:	XIE	PART NO: 产品编号: HDGC4001H-XP-A			
X.XX	±0.30	X.XX°	±2°	CHECK: 校对:	WANG	DATE	SCALE	UNIT	CODE NUMBER
X.XXX	±0.10	X.XXX°	±1°	DRAW: 绘图:	WANG	2012-03-21	5:1	mm	A008

修订 REV	标记 MARK	修改摘要 REVISION DESCRIPTION	签名 SIGNATURE	日期 DATE
AO		NEW RELEASE	WANG	2011-06-08

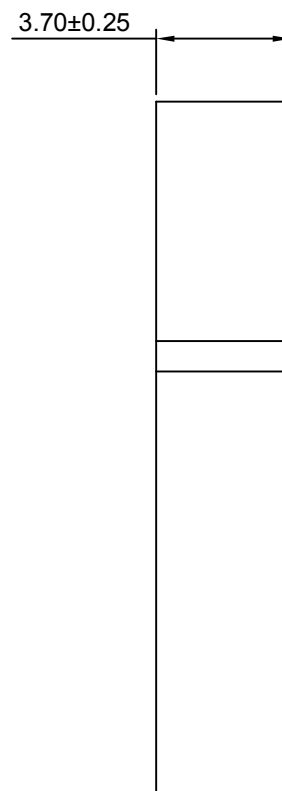
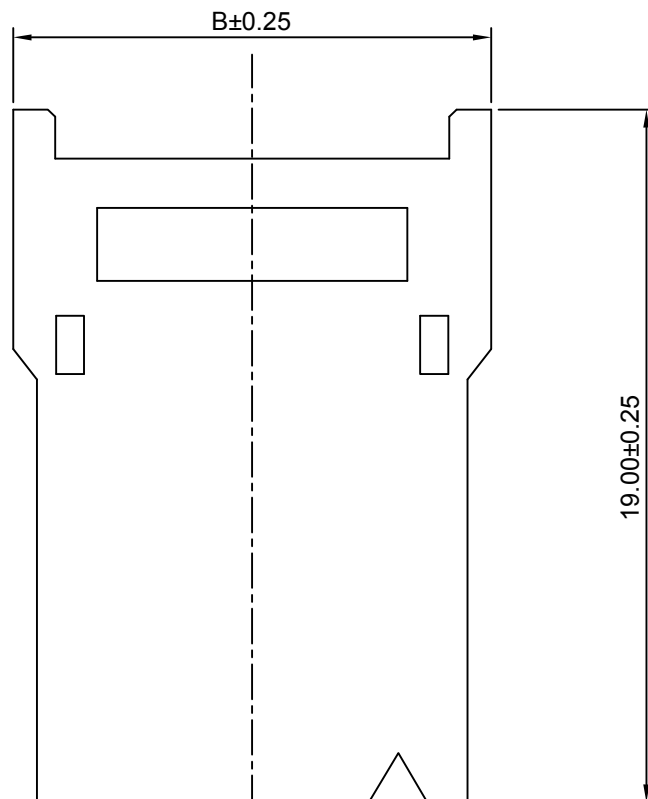
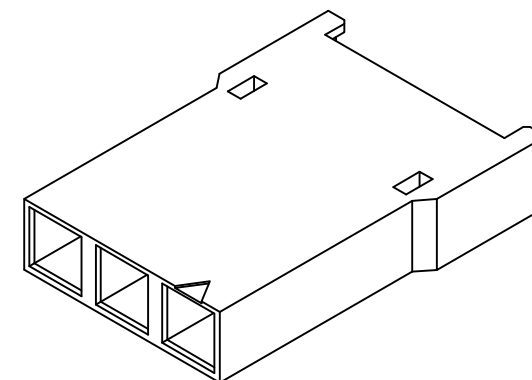
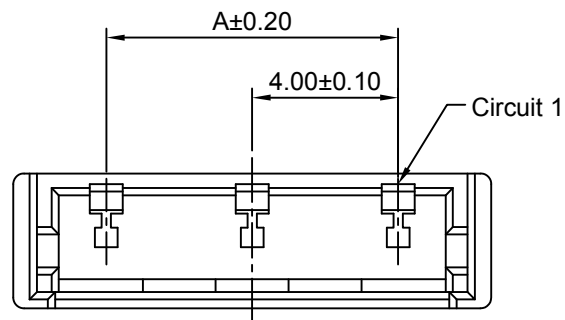

SPECIFICATIONS:

Current Rating: 1A AC,DC
Voltage Rating: 600V AC,DC
Temperature Range: -25°C ~ +85°C
Contact Resistance: 10mΩ Max
Insulation Resistance: 1000MΩ Min
Withstanding Voltage: 1800V AC/minute
Material: Nylon 66 ,UL94V-0(White)

Ordering Information & Dimensions

Circuits	Dimensions(mm)		Circuits	Dimensions(mm)	
	A	B		A	B
2P	4.00	9.10	4P	12.00	17.10
3P	8.00	13.10	5P	16.00	21.10



深圳市华德共创科技有限公司

SHENZHEN HUADE CO-CREATE TECHNOLOGY CO.,LTD

TEL : 0755-27129737 FAX : 0755-29940187

-TOLERANCES- UNLESS OTHERWISE SPECIFIED 公差参数表						TITLE: 4.00mm Pitch 产品名称: Housing			
X.X	±0.30	X.X°	±3°	APPD: 核准:	XIE	PART NO: 产品编号: HDGC4001HM-XP			
X.XX	±0.30	X.XX°	±2°	CHECK: 校对:	WANG	DATE	SCALE	UNIT	CODE NUMBER
X.XXX	±0.10	X.XXX°	±1°	DRAW: 绘图:	WANG	2011-06-08	5:1	mm	A008

修订 REV	标记 MARK	修改摘要 REVISION DESCRIPTION	签名 SIGNATURE	日期 DATE
AO		NEW RELEASE	WANG	2011-06-08

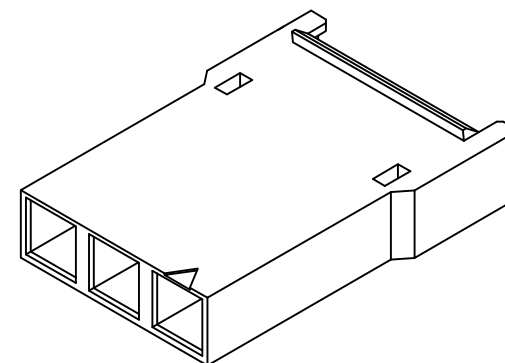
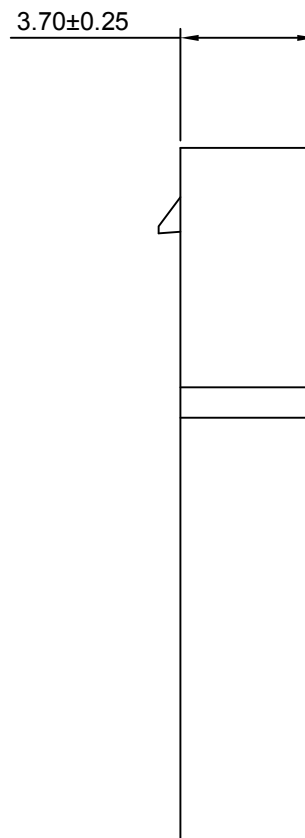
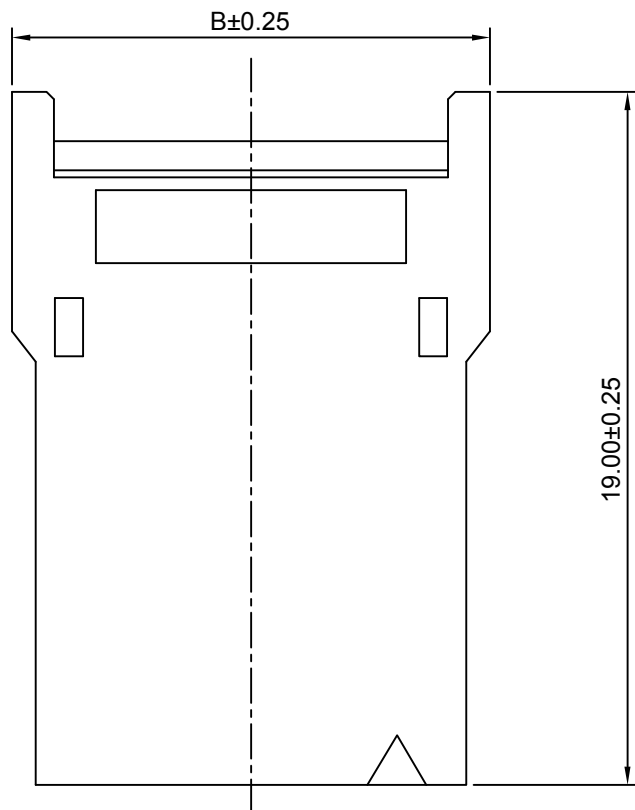
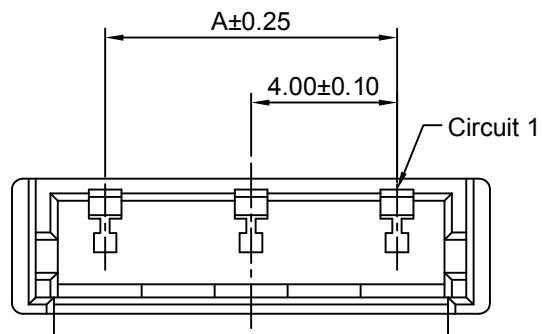

SPECIFICATIONS:

Current Rating: 1A AC,DC
Voltage Rating: 600V AC,DC
Temperature Range: -25°C ~ +85°C
Contact Resistance: 10mΩ Max
Insulation Resistance: 1000MΩ Min
Withstanding Voltage: 1800V AC/minute
Material: Nylon 66 , UL94V-0(White)

Ordering Information & Dimensions

Circuits	Dimensions(mm)		Circuits	Dimensions(mm)	
	A	B		A	B
2P	4.00	9.10	4P	12.00	17.10
3P	8.00	13.10	5P	16.00	21.10



深圳市华德共创科技有限公司

SHENZHEN HUADE CO-CREATE TECHNOLOGY CO.,LTD

TEL : 0755-27129737 FAX : 0755-29940187

-TOLERANCES- UNLESS OTHERWISE SPECIFIED 公差参数表				TITLE: 产品名称: 4.00mm Pitch Housing					
X.X	±0.30	X.X°	±3°	APPD: 核准:	XIE	PART NO: 产品编号:	HDGC4001HMA-XP		
X.XX	±0.30	X.XX°	±2°	CHECK: 校对:	WANG	DATE	SCALE	UNIT	CODE NUMBER
X.XXX	±0.10	X.XXX°	±1°	DRAW: 绘图:	WANG	2011-06-08	5:1	mm	A008

修订 REV	标记 MARK	修改摘要 REVISION DESCRIPTION	签名 SIGNATURE	日期 DATE
AO		NEW RELEASE	WANG	2012-03-21

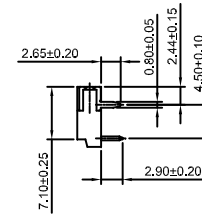
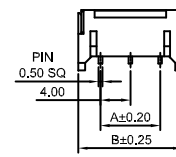
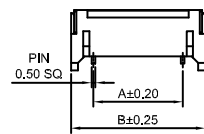
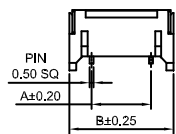
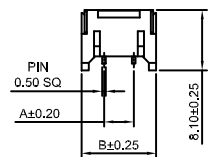
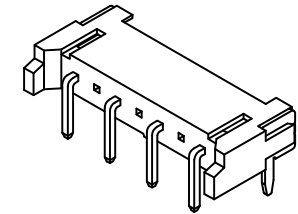
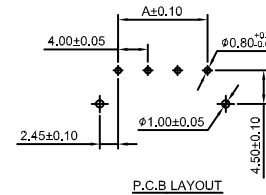
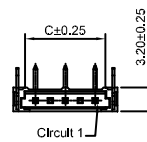
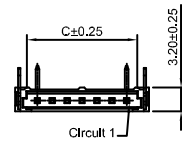
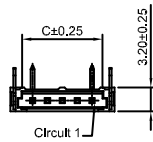
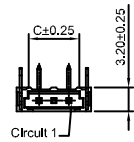

SPECIFICATIONS:

Current Rating: 1A AC,DC
Voltage Rating: 600V AC,DC
Temperature Range: -25°C ~ +85°C
Contact Resistance: 10mΩ Max
Insulation Resistance: 1000MΩ Min
Withstanding Voltage: 1800V AC/minute
PIN Material: Brass/Tin over Nickel
Solder PIN Material: Brass/Tin over Nickel
Material: Nylon 6T,UL94V-0(Beige)

HDGC4001WR-2P-1

HDGC4001WR-2P-2

HDGC4001WR-2P-3

HDGC4001WR-3P

Ordering Information & Dimensions

Circuits	Dimensions(mm)			Circuits	Dimensions(mm)		
	A	B	C		A	B	C
2P-1	4.00	10.00	6.80	4P-137	12.00	18.00	14.80
2P-2	8.00	14.00	10.80	4P-157	12.00	18.00	14.80
2P-3	12.00	18.00	14.80	4P	12.00	18.00	14.80
3P	8.00	14.00	10.80	5P	16.00	22.00	18.80

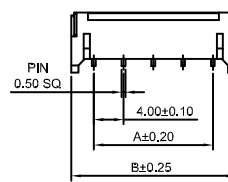
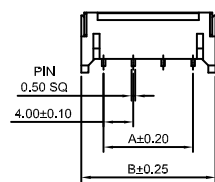
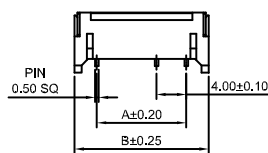
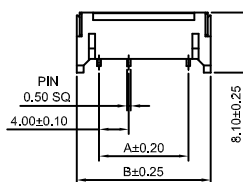
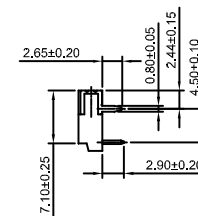
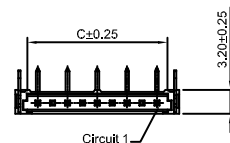
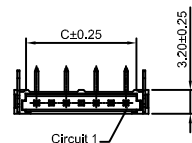
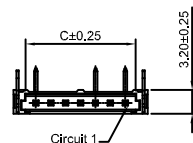
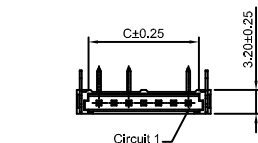

HDGC4001WR-4P-137

HDGC4001WR-4P-157

HDGC4001WR-4P

HDGC4001WR-5P



深圳市华德共创科技有限公司

SHENZHEN HUADE CO-CREATE TECHNOLOGY CO.,LTD

TEL : 0755-27129737 FAX : 0755-29940187

-TOLERANCES- UNLESS OTHERWISE SPECIFIED 公差参数表						TITLE: 4.00mm Pitch 产品名称: 90° Wafer			
X.X	±0.30	X.X°	±3°	APPD: 核准:	XIE	PART NO: 产品编号: HDGC4001WR-XP			
X.XX	±0.30	X.XX°	±2°	CHECK: 校对:	WANG	DATE	SCALE	UNIT	CODE NUMBER
X.XXX	±0.10	X.XXX°	±1°	DRAW: 绘图:	WANG	2012-03-21	1:1	mm	A008

修订 REV	标记 MARK	修改摘要 REVISION DESCRIPTION	签名 SIGNATURE	日期 DATE
AO		NEW RELEASE	WANG	2012-03-21

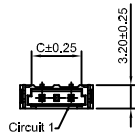

Circuit 1

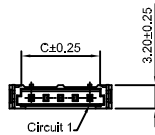

Circuit 1

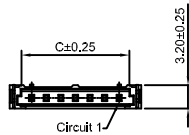

Circuit 1

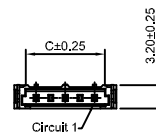

Circuit 1

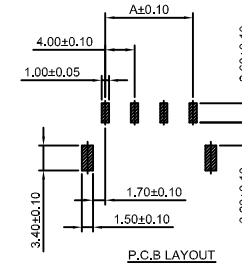

P.C.B LAYOUT

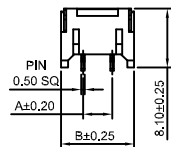
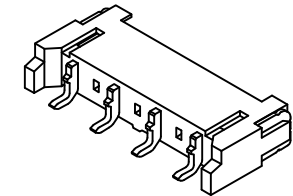

HDGC4001WR-S-2P-1

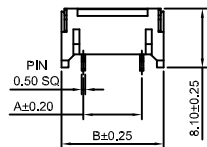

HDGC4001WR-S-2P-2

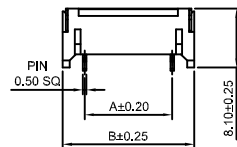

HDGC4001WR-S-2P-3

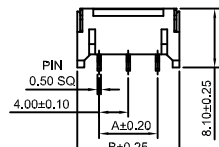

HDGC4001WR-S-3P

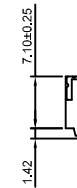
7.10±0.25
1.42

SPECIFICATIONS:

Current Rating: 1A AC,DC
Voltage Rating: 600V AC,DC
Temperature Range: -25°C ~ +85°C
Contact Resistance: 10mΩ Max
Insulation Resistance: 1000MΩ Min
Withstanding Voltage: 1800V AC/minute
PIN Material: Brass/Tin over Nickel
Solder PIN Material: Brass/Tin over Nickel
Material: Nylon 6T,UL94V-0(Beige)

Ordering Information & Dimensions

Circuits	Dimensions(mm)			Circuits	Dimensions(mm)		
	A	B	C		A	B	C
2P-1	4.00	10.00	6.80	4P-137	12.00	18.00	14.80
2P-2	8.00	14.00	10.80	4P-157	12.00	18.00	14.80
2P-3	12.00	18.00	14.80	4P	12.00	18.00	14.80
3P	8.00	14.00	10.80	5P	16.00	22.00	18.80

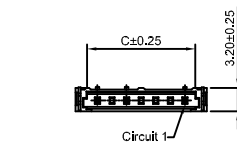

Circuit 1

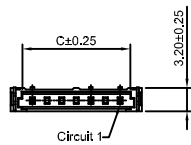

Circuit 1

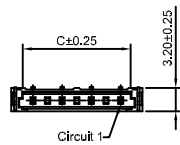

Circuit 1

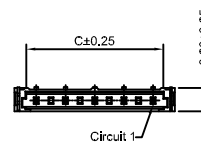

Circuit 1

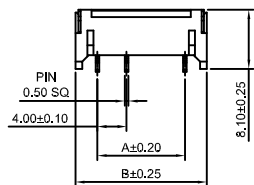

HDGC4001WR-S-4P-137

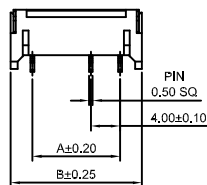

HDGC4001WR-S-4P-157

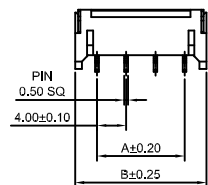

HDGC4001WR-S-4P

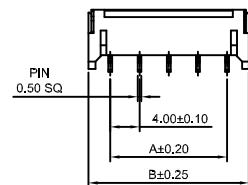

HDGC4001WR-S-5P

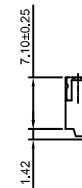
7.10±0.25
1.42



深圳市华德共创科技有限公司
SHENZHEN HUADE CO-CREATE TECHNOLOGY CO.,LTD
TEL : 0755-27129737 FAX : 0755-29940187

-TOLERANCES- UNLESS OTHERWISE SPECIFIED 公差参数表				TITLE: 4.00mm Pitch 产品名称: 90° Wafer							
X.X	±0.30	X.X°	±3°	APPD: 核准:	XIE			PART NO: 产品编号:	HDGC4001WR-S-XP		
X.XX	±0.30	X.XX°	±2°	CHECK: 校对:	WANG			DATE	SCALE	UNIT	CODE NUMBER
X.XXX	±0.10	X.XXX°	±1°	DRAW: 绘图:	WANG			2012-03-21	1:1	mm	A008

修订 REV	标记 MARK	修改摘要 REVISION DESCRIPTION	签名 SIGNATURE	日期 DATE
AO		NEW RELEASE	WANG	2012-03-21

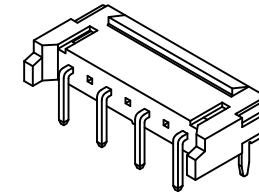
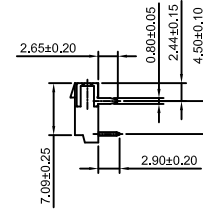
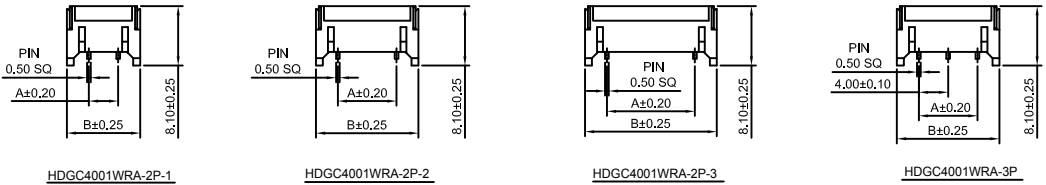
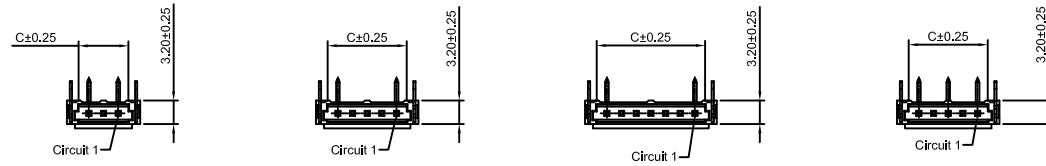

SPECIFICATIONS:

Current Rating: 1A AC,DC
Voltage Rating: 600V AC,DC
Temperature Range: -25°C ~ +85°C
Contact Resistance: 10mΩ Max
Insulation Resistance: 1000MΩ Min
Withstanding Voltage: 1800V AC/minute
PIN Material: Brass/Tin over Nickel
Solder PIN Material: Brass/Tin over Nickel
Material: Nylon 6T,UL94V-0 (Beige)

Ordering Information & Dimensions

Circuits	Dimensions(mm)			Circuits	Dimensions(mm)		
	A	B	C		A	B	C
2P-1	4.00	10.00	6.80	4P-137	12.00	18.00	14.80
2P-2	8.00	14.00	10.80	4P-157	12.00	18.00	14.80
2P-3	12.00	18.00	14.80	4P	12.00	18.00	14.80
3P	8.00	14.00	10.80	5P	16.00	22.00	18.80

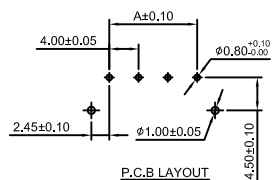
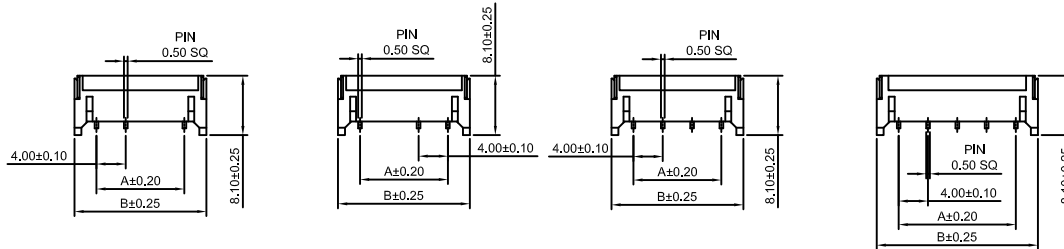
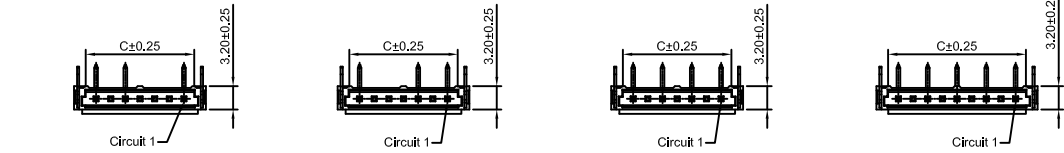
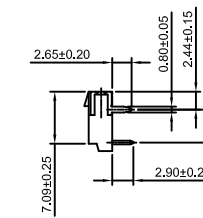



深圳市华德共创科技有限公司
SHENZHEN HUADE CO-CREATE TECHNOLOGY CO.,LTD
TEL : 0755-27129737 FAX : 0755-29940187

-TOLERANCES- UNLESS OTHERWISE SPECIFIED 公差参数表					TITLE: 4.00mm Pitch			
				产品名称: 90° Wafer				
X.X	±0.30	X.X°	±3°	APPD: 核准:	XIE			
X.XX	±0.30	X.XX°	±2°	CHECK: 校对:	WANG			
X.XXX	±0.10	X.XXX°	±1°	DRAW: 绘图:	WANG			
PART NO: 产品编号:					HDGC4001WRA-XP			
		DATE	SCALE	UNIT	CODE NUMBER			
		2012-03-21	1:1	mm	A008			

修订 REV	标记 MARK	修改摘要 REVISION DESCRIPTION	签名 SIGNATURE	日期 DATE
AO		NEW RELEASE	WANG	2012-03-21

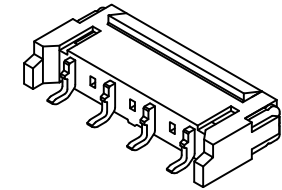
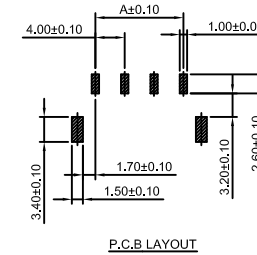
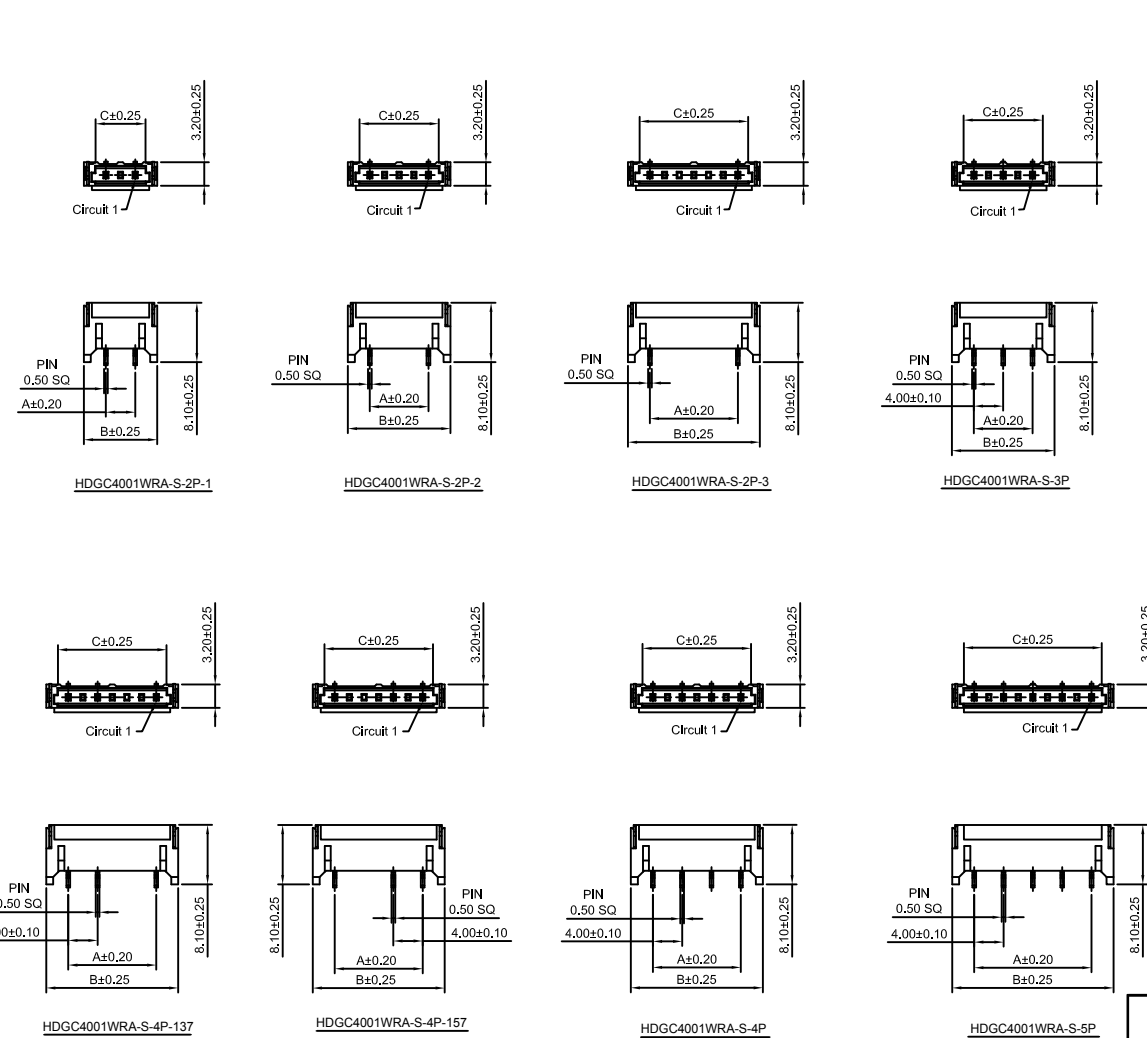

SPECIFICATIONS:

Current Rating: 1A AC,DC
Voltage Rating: 600V AC,DC
Temperature Range: -25°C ~ +85°C
Contact Resistance: 10mΩ Max
Insulation Resistance: 1000MΩ Min
Withstanding Voltage: 1800V AC/minute
PIN Material: Brass/Tin over Nickel
Solder PIN Material: Brass/Tin over Nickel
Material: Nylon 6T, UL94V-0 (Beige)

Ordering Information & Dimensions

Circuits	Dimensions(mm)			Circuits	Dimensions(mm)		
	A	B	C		A	B	C
2P-1	4.00	10.00	6.80	4P-137	12.00	18.00	14.80
2P-2	8.00	14.00	10.80	4P-157	12.00	18.00	14.80
2P-3	12.00	18.00	14.80	4P	12.00	18.00	14.80
3P	8.00	14.00	10.80	5P	16.00	22.00	18.80



深圳市华德共创科技有限公司

SHENZHEN HUADE CO-CREATE TECHNOLOGY CO.,LTD

TEL : 0755-27129737 FAX : 0755-29940187

-TOLERANCES- UNLESS OTHERWISE SPECIFIED 公差参数表						TITLE: 4.00mm Pitch 产品名称: 90° Wafer			
X.X	±0.30	X.X°	±3°	APPD: 核准:	XIE	PART NO: 产品编号: HDGC4001WRA-S-XP			
X.XX	±0.30	X.XX°	±2°	CHECK: 校对:	WANG	DATE	SCALE	UNIT	CODE NUMBER
X.XXX	±0.10	X.XXX°	±1°	DRAW: 绘图:	WANG	2012-03-21	1:1	mm	A008