

修订 REV	标记 MARK	修改摘要 REVISION DESCRIPTION	签名 SIGNATURE	日期 DATE
AO		NEW RELEASE	WANG	2017-03-29

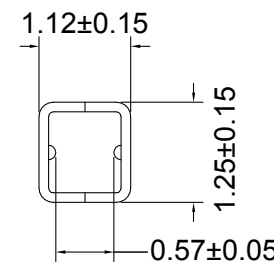
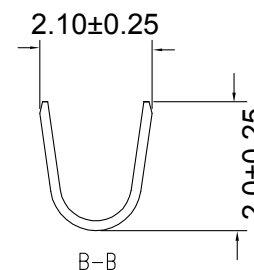
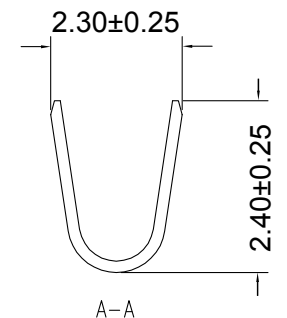
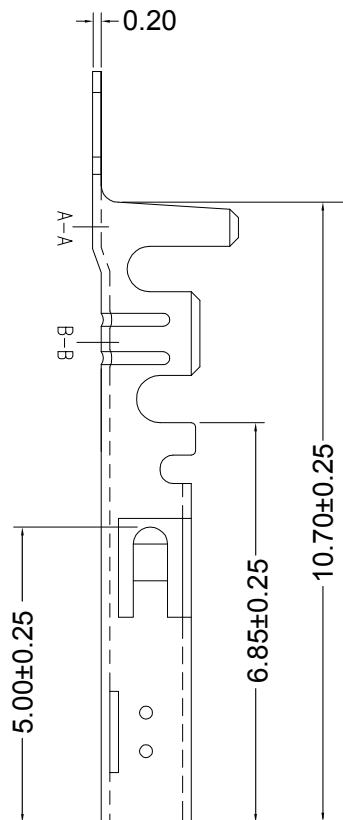
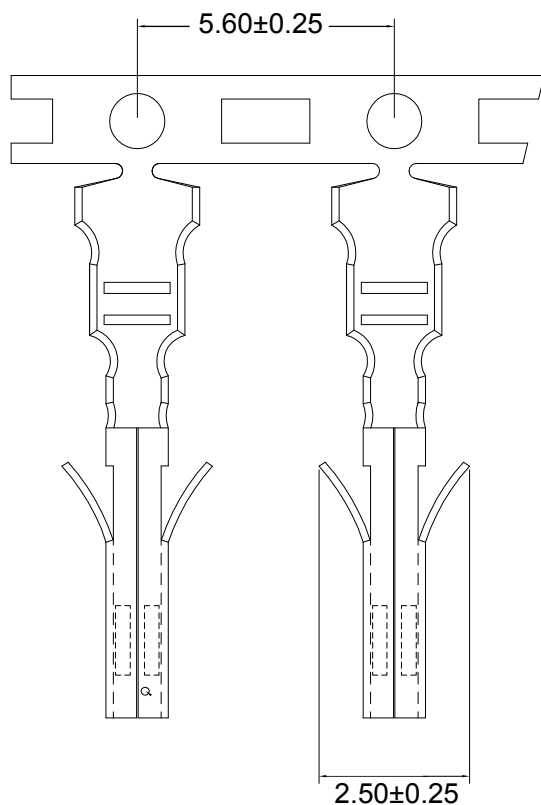

注意：配用的公座针是0.65四方PIN

NOTE:

1. THICKNE: 0.20mm.
2. MATERIAL: PHOSPHOR/BRASS BRONZE
3. FINISH: 镍底30-50<sup>U</sup> 镀锡80-120<sup>U</sup>
4. APPLICABLE WIRE: AWG20-24 #

5. 使用量具为电子卡尺
6. PVC与铜丝包脚需压角.

		<b>深圳市华德共创科技有限公司</b> Shenzhen Huade co-create Technology Co.,LTD TEL : 0755-27129737 FAX : 0755-29940187					
		TITLE: 产品名称: MX3.0母端 PART NO: 产品编号: HDGC3030-T					
-TOLERANCES- UNLESS OTHERWISE SPECIFIED 公差参数表				APPD: 核准: XIE CHECK: 校对: WANG DRAW: 绘图: WANG			
X.X	±0.30	X.X°	±3°	DATE	SCALE	UNIT	CODE NUMBER
X.XX	±0.30	X.XX°	±2°	2017-03-29	8:1	mm	A002
X.XXX	±0.10	X.XXX°	±1°				

修订 REV	标记 MARK	修改摘要 REVISION DESCRIPTION	签名 SIGNATURE	日期 DATE
AO		NEW RELEASE	WANG	2015-10-30

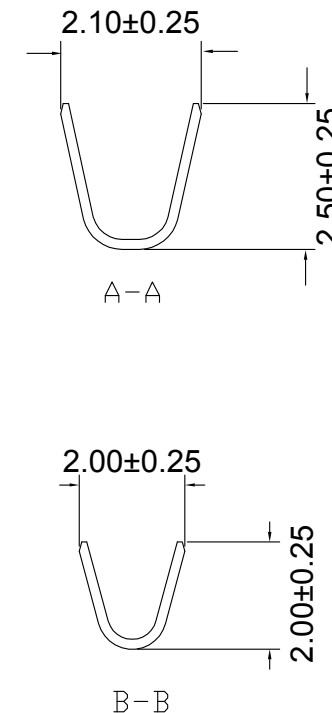
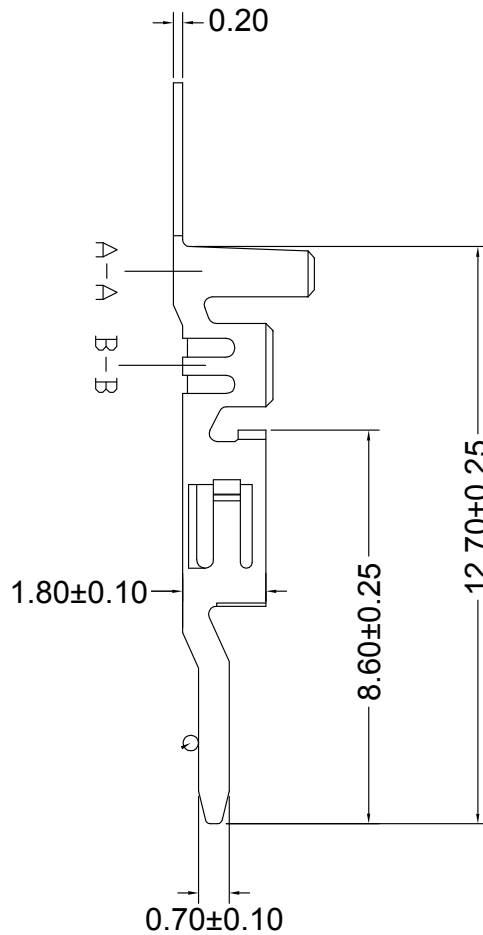
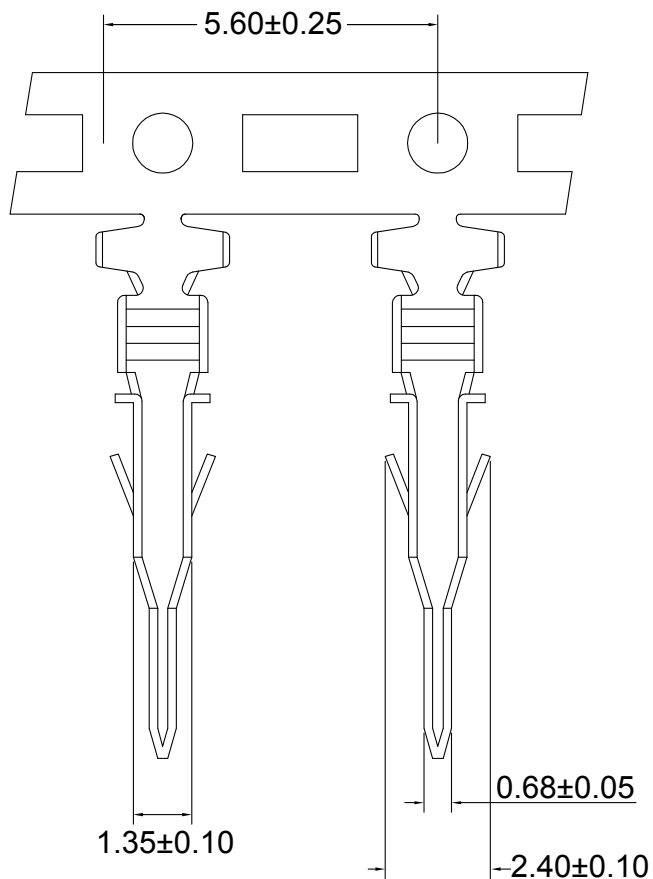

NOTE:

1. THICKNE : 0.20mm.
2. MATERIAL : PHOSPHOR/BRASS BRONZE
3. FINISH : 镍底30-50<sup>U</sup> 镀锡80-120<sup>U</sup>
4. APPLICABLE WIRE : AWG20-24 #

5. 使用量具为电子卡尺
6. PVC与铜丝包脚需压角.

		<b>深圳市华德共创科技有限公司</b> Shenzhen Huade co-create Technology Co.,LTD TEL : 0755-27129737 FAX : 0755-29940187						
		-TOLERANCES- UNLESS OTHERWISE SPECIFIED 公差参数表				TITLE: 产品名称: MX3.0公端		
X.X	±0.30	X.X°	±3°	APPD: 核准: XIE	PART NO: 产品编号: HDGC3030M-T			
X.XX	±0.30	X.XX°	±2°	CHECK: 校对: WANG	DATE	SCALE	UNIT	CODE NUMBER
X.XXX	±0.10	X.XXX°	±1°	DRAW: 绘图: WANG	2015-10-30	8:1	mm	A002

修订 REV	标记 MARK	修改摘要 REVISION DESCRIPTION	签名 SIGNATURE	日期 DATE
AO		NEW RELEASE	WANG	2015-07-12

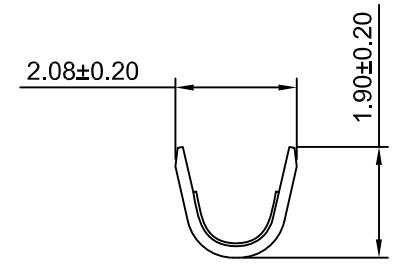
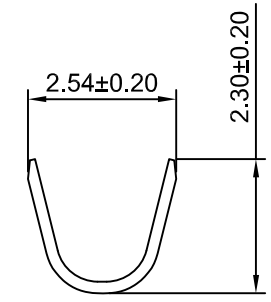
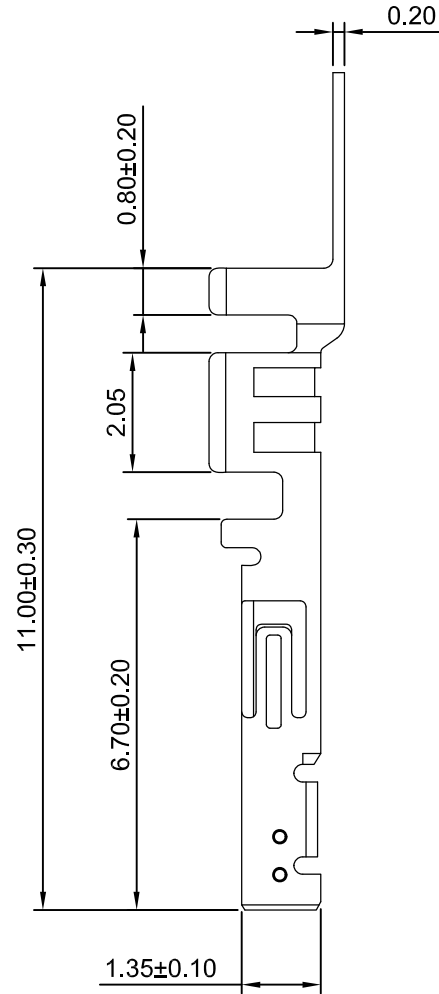
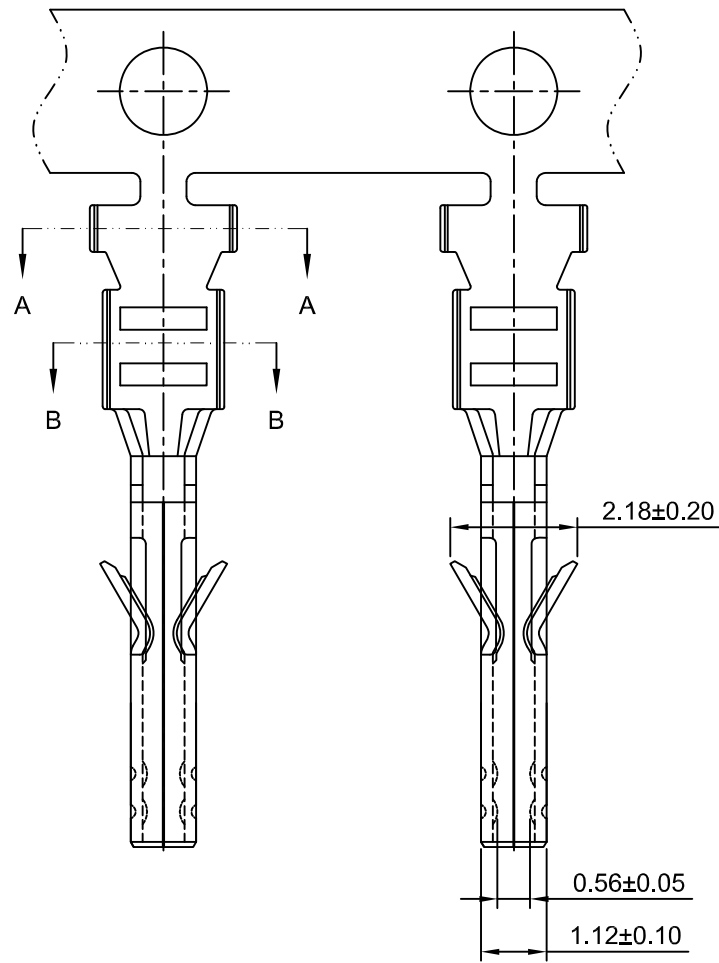

Ordering information & Specifications

Part No	Wire Range	Insulation O.D.	Material	Finish	Qty/reel
HDGCC3030F-TP-A	AWG#20-#24	1.85mm(max)	Phosphor Bronze	Tin over Nickel	10,000 PCS
HDGCC3030F-GP-A	AWG#20-#24	1.85mm(max)	Phosphor Bronze	Gold over Nickel	10,000 PCS

Optional Gold plating available but MOQ requested



深圳市华德共创科技有限公司

SHENZHEN HUADE CO-CREATE TECHNOLOGY CO.,LTD  
TEL : 0755-27129737 FAX : 0755-29940187

-TOLERANCES- UNLESS OTHERWISE SPECIFIED 公差参数表				TITLE: 产品名称: 3.00mm Pitch Crimp Terminal	
X.X	±0.30	X.X°	±3°	APPD: 核准: XIE	PART NO: 产品编号: HDGCC3030F-T-A
X.XX	±0.30	X.XX°	±2°	CHECK: 校对: WANG	DATE
X.XXX	±0.10	X.XXX°	±1°	DRAW: 绘图: WANG	SCALE
					UNIT
					CODE NUMBER
					A008

修订 REV	标记 MARK	修改摘要 REVISION DESCRIPTION	签名 SIGNATURE	日期 DATE
AO		NEW RELEASE	WANG	2017-10-12

Ordering Information:  
 HDGCC3030F-TP-A-H - \*\*  
 1 2

- Part No.
- Finish  
 (blank): Gold-flash  
 100µin (2.54µm) MIN.Select Tin  
 G15:15µin (0.38µm) MIN.Select Gold  
 100µin (2.54µm) MIN.Select Tin  
 G30:30µin (0.76µm) MIN.Select Gold  
 100µin (2.54µm) MIN.Select Tin

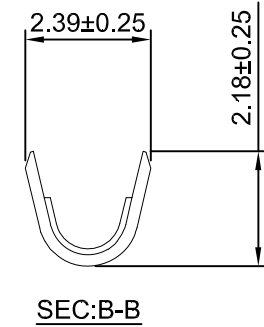
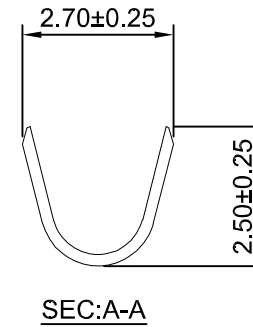
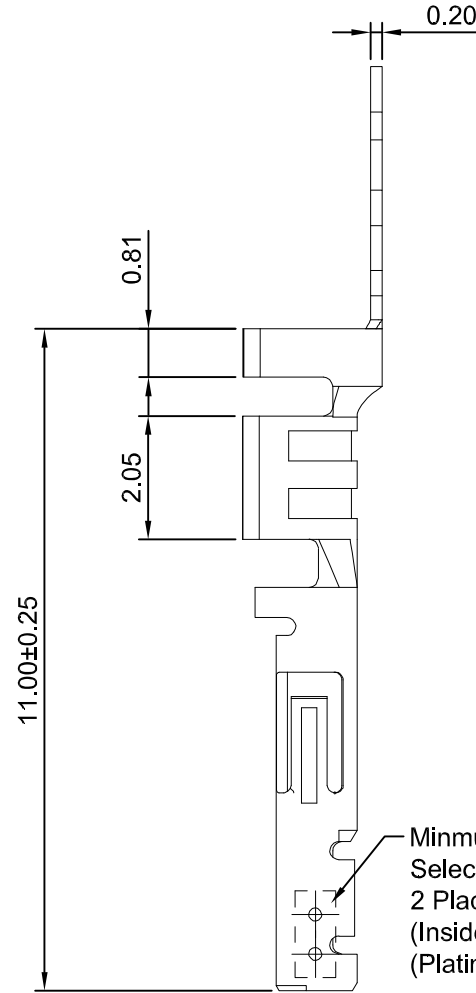
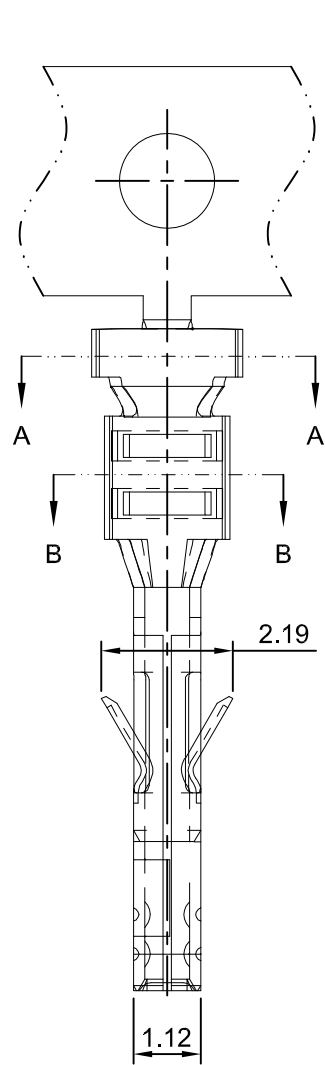

Ordering information & Specifications

Unit:mm

Part No	Wire Range	Insulation O.D.	Material	Finish	Qty/reel
HDGCC3030F-TP-A-H	AWG#18 OR 0.75mm <sup>2</sup>	1.85mm(max)	Phosphor Bronze	Tin over Nickel	10,000 PCS
HDGCC3030F-GP-A-H	AWG#18 OR 0.75mm <sup>2</sup>	1.85mm(max)	Phosphor Bronze	Gold over Nickel	10,000 PCS



深圳市华德共创科技有限公司

SHENZHEN HUADE CO-CREATE TECHNOLOGY CO.,LTD

TEL : 0755-27129737 FAX : 0755-29940187

-TOLERANCES- UNLESS OTHERWISE SPECIFIED 公差参数表					TITLE: 3.00mm Pitch 产品名称: Crimp Terminal				
X.X	±0.30	X.X°	±3°	APPD: 核准:	XIE				
X.XX	±0.30	X.XX°	±2°	CHECK: 校对:	WANG	DATE	SCALE	UNIT	CODE NUMBER
X.XXX	±0.10	X.XXX°	±1°	DRAW: 绘图:	WANG	2017-10-12	8:1	mm	A008

修订 REV	标记 MARK	修改摘要 REVISION DESCRIPTION	签名 SIGNATURE	日期 DATE
AO		NEW RELEASE	WANG	2015-07-12

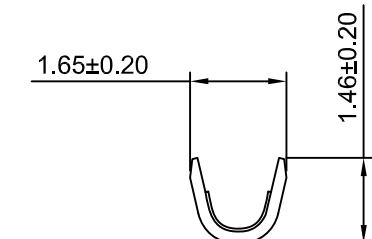
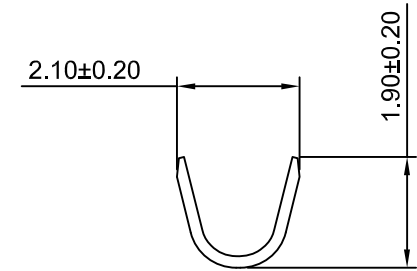
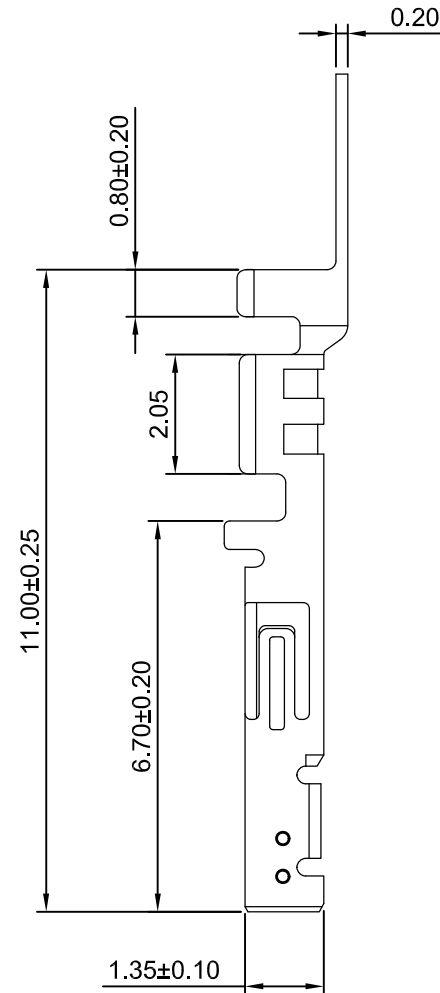
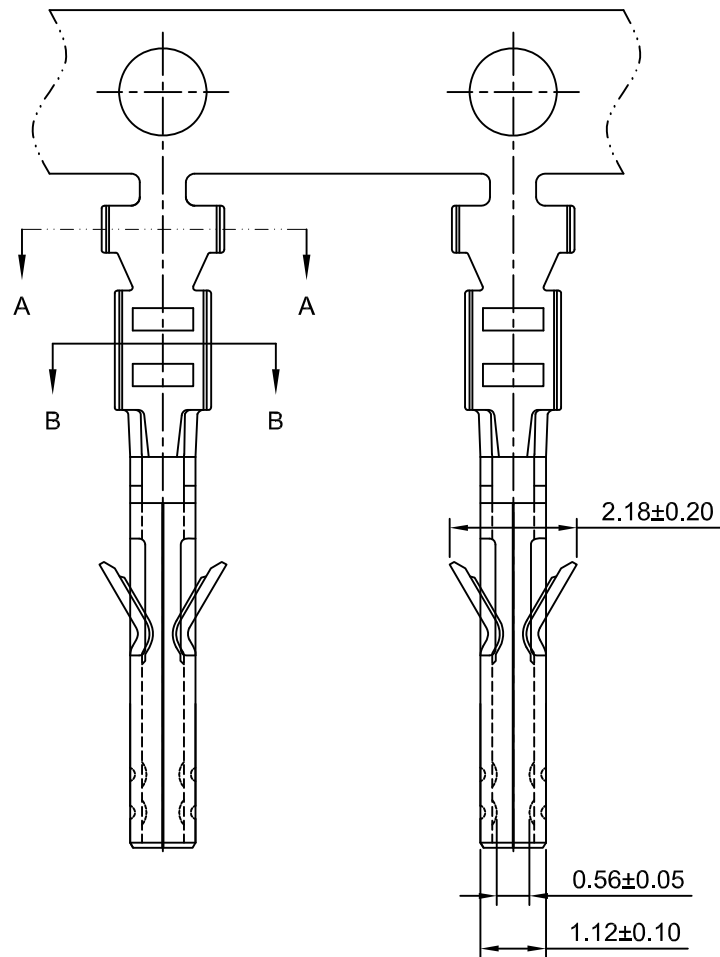

Ordering information & Specifications

Unit:mm

Part No	Wire Range	Insultion O.D.	Material	Finish	Qty/reel
HDGCC3030F-TP-A-L	AWG#26-#30	1.27mm(max)	Phosphor Bronze	Tin over Nickel	10,000 PCS
HDGCC3030F-GP-A-L	AWG#26-#30	1.27mm(max)	Phosphor Bronze	Gold over Nickel	10,000 PCS

Optional Gold plating available but MOQ requested



深圳市华德共创科技有限公司

SHENZHEN HUADE CO-CREATE TECHNOLOGY CO.,LTD

TEL : 0755-27129737 FAX : 0755-29940187

-TOLERANCES- UNLESS OTHERWISE SPECIFIED 公差参数表					TITLE: 产品名称: 3.00mm Pitch Crimp Terminal			
X.X	±0.30	X.X°	±3°	APPD: 核准: XIE	PART NO: 产品编号: HDGC3030F-T-A-L			
X.XX	±0.30	X.XX°	±2°	CHECK: 校对: WANG	DATE	SCALE	UNIT	CODE NUMBER
X.XXX	±0.10	X.XXX°	±1°	DRAW: 绘图: WANG	2015-07-12	8:1	mm	A008

修订 REV	标记 MARK	修改摘要 REVISION DESCRIPTION	签名 SIGNATURE	日期 DATE
AO		NEW RELEASE	WANG	2015-07-12

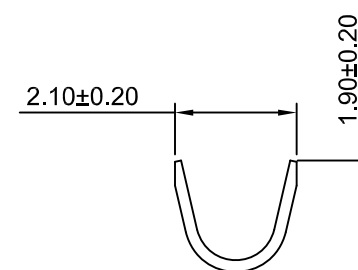
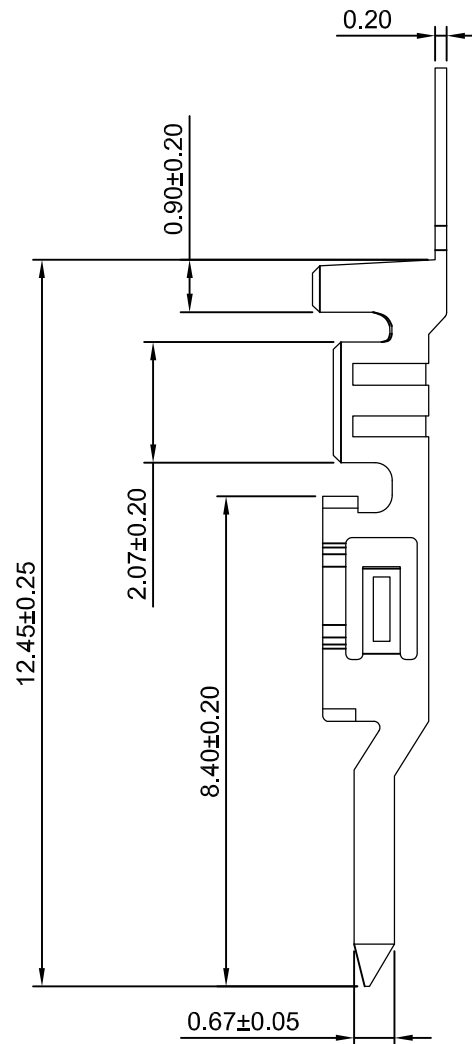
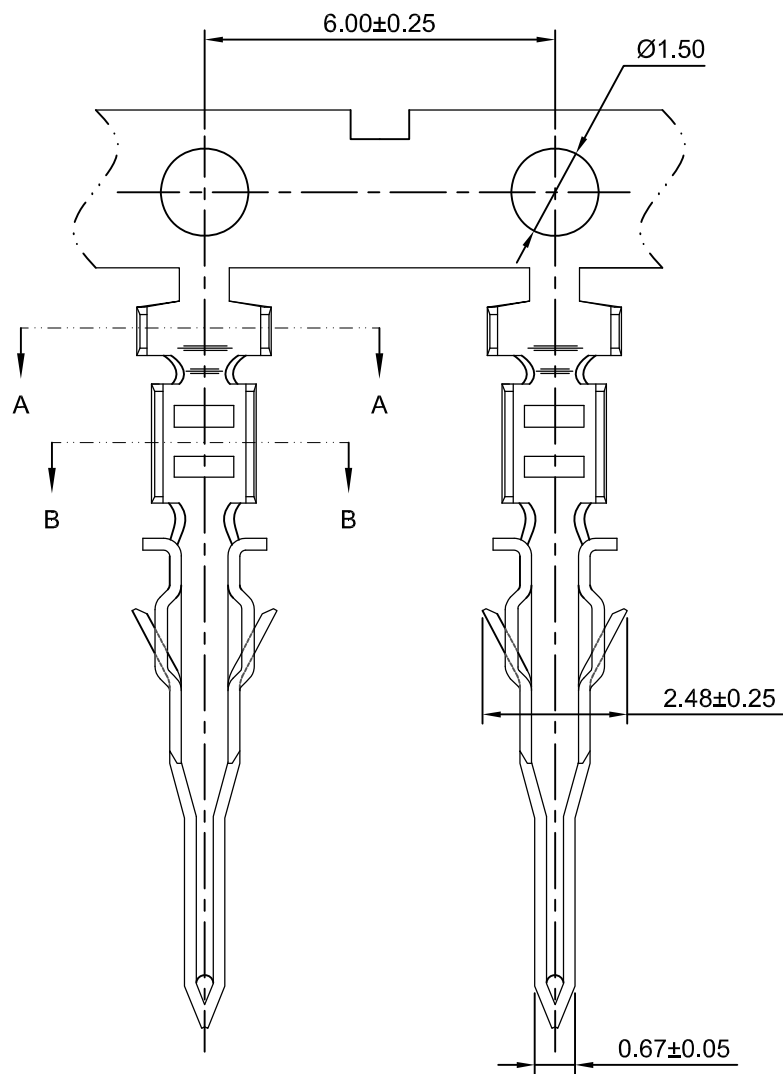

SEC:A-A

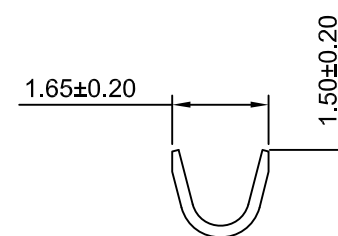

SEC:B-B

Ordering information & Specifications

Unit:mm

Part No	Wire Range	Insulation O.D.	Material	Finish	Qty/reel
HDGCC3030M-TP-L	AWG#26-#30	1.27mm(max)	Phosphor Bronze	Tin over Nickel	10,000 PCS
HDGCC3030M-GP-L	AWG#26-#30	1.27mm(max)	Phosphor Bronze	Gold over Nickel	10,000 PCS

Optional Gold plating available but MOQ requested



深圳市华德共创科技有限公司

SHENZHEN HUADE CO-CREATE TECHNOLOGY CO.,LTD

TEL : 0755-27129737 FAX : 0755-29940187

-TOLERANCES- UNLESS OTHERWISE SPECIFIED 公差参数表						TITLE: 3.00mm Pitch 产品名称: Crimp Terminal			
X.X	±0.30	X.X°	±3°	APPD: 核准:	XIE	PART NO: 产品编号: HDGC3030M-T-L			
X.XX	±0.30	X.XX°	±2°	CHECK: 校对:	WANG	DATE	SCALE	UNIT	CODE NUMBER
X.XXX	±0.10	X.XXX°	±1°	DRAW: 绘图:	WANG	2015-07-12	8:1	mm	A008

修订 REV	标记 MARK	修改摘要 REVISION DESCRIPTION	签名 SIGNATURE	日期 DATE
AO		NEW RELEASE	WANG	2015-07-12

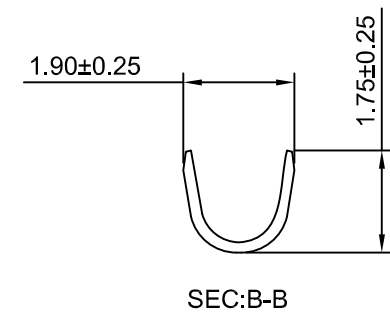
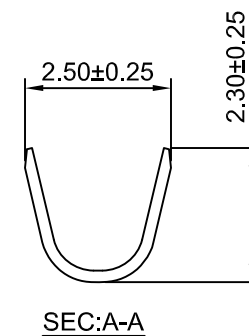
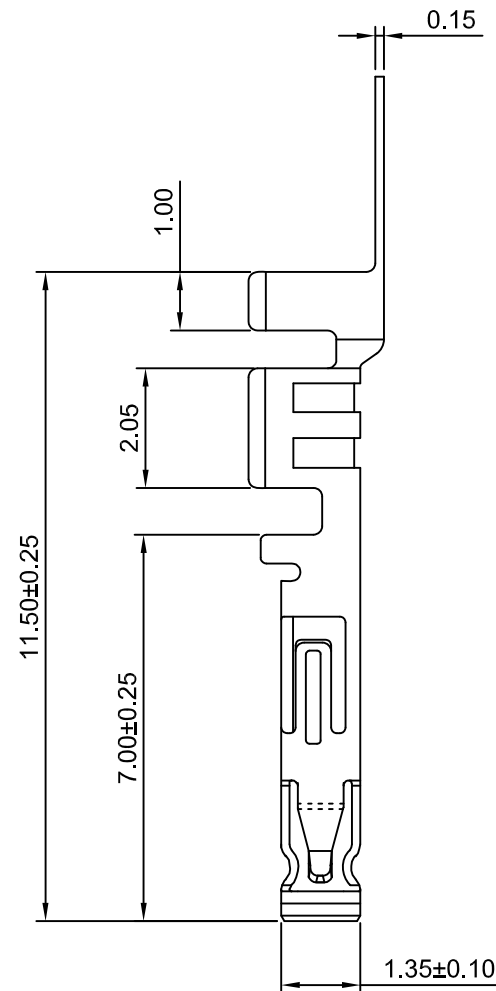
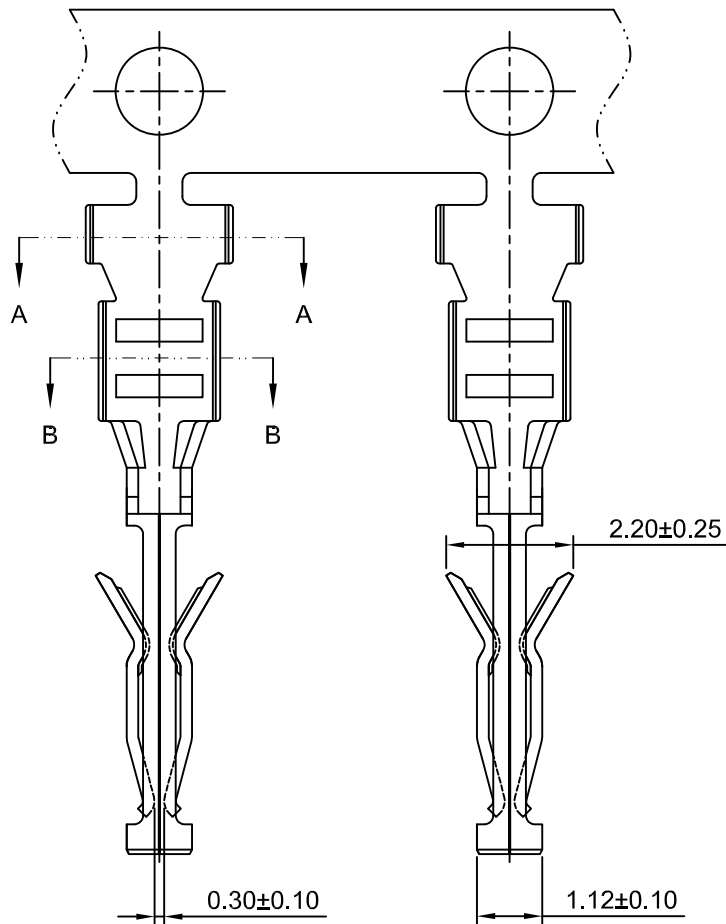

Ordering information & Specifications

Unit:mm

Part No	Wire Range	Insultion O.D.	Material	Finish	Qty/reel
HDGCC3030F-TP-C	AWG#20-#24	1.85mm(max)	Phosphor Bronze	Tin over Nickel	10,000 PCS
HDGCC3030F-GP-C	AWG#20-#24	1.85mm(max)	Phosphor Bronze	Gold over Nickel	10,000 PCS

Optional Gold plating available but MOQ requested



深圳市华德共创科技有限公司

SHENZHEN HUADE CO-CREATE TECHNOLOGY CO.,LTD

TEL : 0755-27129737 FAX : 0755-29940187

-TOLERANCES- UNLESS OTHERWISE SPECIFIED 公差参数表						TITLE: 3.00mm Pitch 产品名称: Crimp Terminal			
X.X	±0.30	X.X°	±3°	APPD: 核准:	XIE	PART NO: 产品编号: HDGC3030F-T-C			
X.XX	±0.30	X.XX°	±2°	CHECK: 校对:	WANG	DATE	SCALE	UNIT	CODE NUMBER
X.XXX	±0.10	X.XXX°	±1°	DRAW: 绘图:	WANG	2015-07-12	8:1	mm	A008

修订 REV	标记 MARK	修改摘要 REVISION DESCRIPTION	签名 SIGNATURE	日期 DATE
AO		NEW RELEASE	WANG	2015-07-12

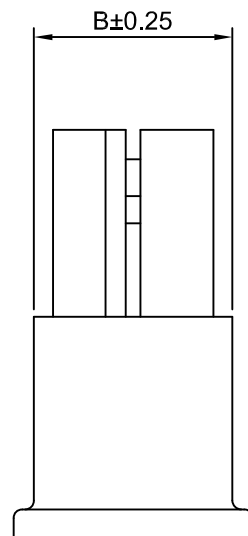
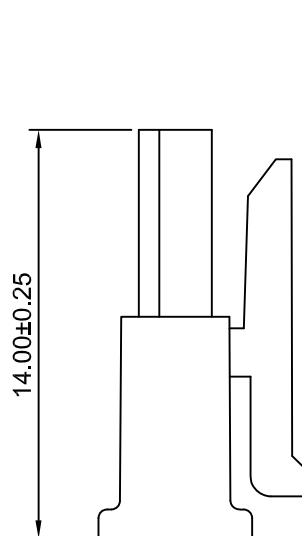
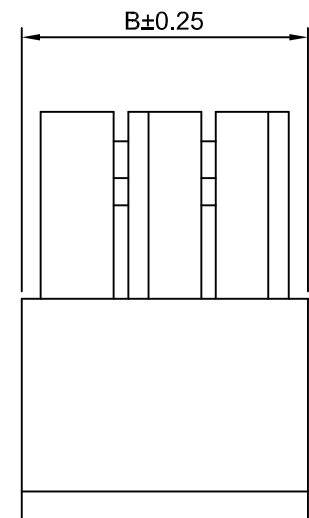
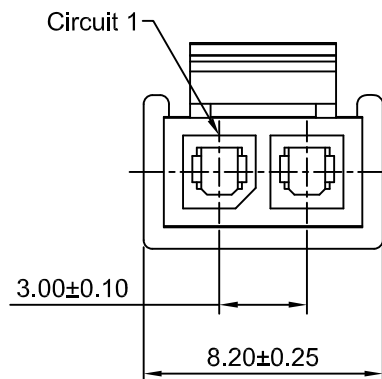
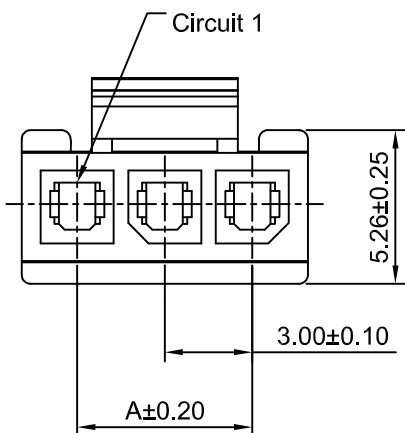

3P~12P

2P

Ordering Information:

HDGC3030HF-XP - \*\*  
1 2

1.Part No.

2.Material:

(blank):Nylon 66 UL94V-0

GWT:Nylon 66 UL94V-0,GWT 750°C

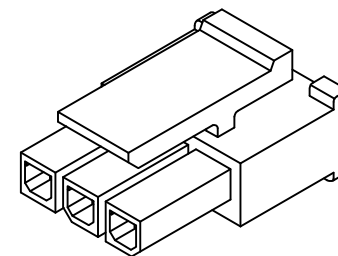

SPECIFICATIONS:

Current Rating: 5A AC,DC  
Voltage Rating: 250V AC,DC  
Temperature Range: -25°C ~ +85°C  
Contact Resistance: 10mΩ Max  
Insulation Resistance: 1000MΩ Min  
Withstanding Voltage: 1500V AC/minute  
Material: Nylon 66,UL94V-0 (Black)

Ordering Information & Dimensions

Circuits	Dimensions(mm)		Circuits	Dimensions(mm)	
	A	B		A	B
2P	3.00	6.85	8P	21.00	24.85
3P	6.00	9.85	9P	24.00	27.85
4P	9.00	12.85	10P	27.00	30.85
5P	12.00	15.85	11P	30.00	33.85
6P	15.00	18.85	12P	33.00	36.85
7P	18.00	21.85			



深圳市华德共创科技有限公司

SHENZHEN HUADE CO-CREATE TECHNOLOGY CO.,LTD

TEL : 0755-27129737 FAX : 0755-29940187

-TOLERANCES- UNLESS OTHERWISE SPECIFIED 公差参数表				TITLE: 产品名称: 3.00mm Pitch Housing	
X.X	±0.30	X.X°	±3°	APPD: 核准:	XIE
X.XX	±0.30	X.XX°	±2°	CHECK: 校对:	WANG
X.XXX	±0.10	X.XXX°	±1°	DRAW: 绘图:	WANG
PART NO: 产品编号:			HDGC3030HF-XP		
DATE	SCALE	UNIT	CODE NUMBER		
2015-07-12	4:1	mm	A008		

修订 REV	标记 MARK	修改摘要 REVISION DESCRIPTION	签名 SIGNATURE	日期 DATE
AO		NEW RELEASE	WANG	2015-07-12

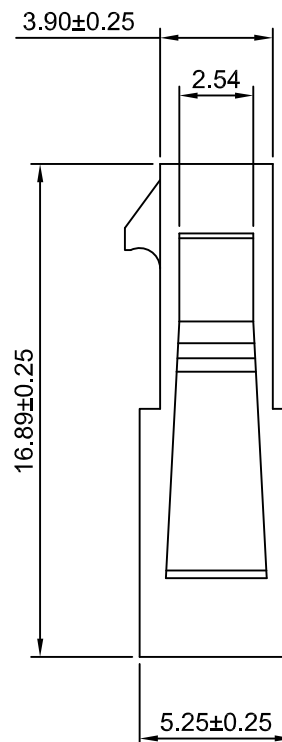
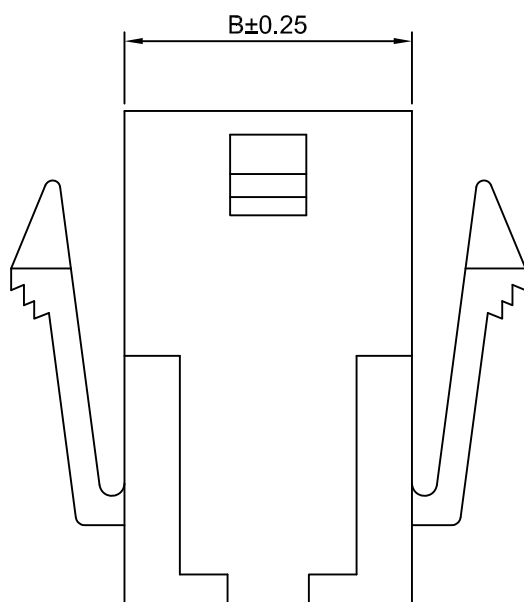
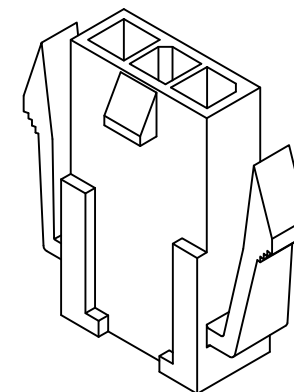
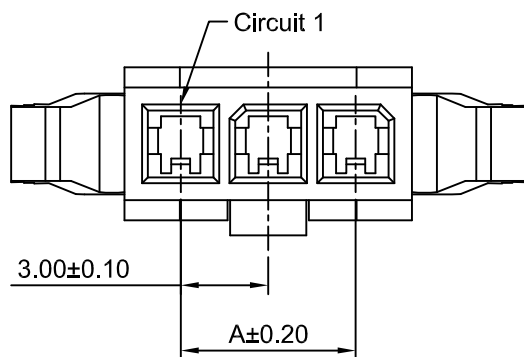

**SPECIFICATIONS:**

Current Rating: 5A AC,DC  
Voltage Rating: 250V AC,DC  
Temperature Range: -25°C ~ +85°C  
Contact Resistance: 10mΩ Max  
Insulation Resistance: 1000MΩ Min  
Withstanding Voltage: 1500V AC/minute  
Material: Nylon 66,UL94V-0(Black)

**Ordering Information & Dimensions**

Circuits	Dimensions(mm)		Circuits	Dimensions(mm)	
	A	B		A	B
2P	3.00	6.85	8P	21.00	24.85
3P	6.00	9.85	9P	24.00	27.85
4P	9.00	12.85	10P	27.00	30.85
5P	12.00	15.85	11P	30.00	33.85
6P	15.00	18.85	12P	33.00	36.85
7P	18.00	21.85			



**深圳市华德共创科技有限公司**

SHENZHEN HUADE CO-CREATE TECHNOLOGY CO.,LTD

TEL : 0755-27129737 FAX : 0755-29940187

-TOLERANCES- UNLESS OTHERWISE SPECIFIED 公差参数表						TITLE: 3.00mm Pitch Housing 产品名称:			
X.X	±0.30	X.X°	±3°	APPD: 核准:	XIE	PART NO: HDGC3030HM-XP 产品编号:			
X.XX	±0.30	X.XX°	±2°	CHECK: 校对:	WANG	DATE	SCALE	UNIT	CODE NUMBER
X.XXX	±0.10	X.XXX°	±1°	DRAW: 绘图:	WANG	2015-07-12	4:1	mm	A008

修订 REV	标记 MARK	修改摘要 REVISION DESCRIPTION	签名 SIGNATURE	日期 DATE
AO		NEW RELEASE	WANG	2015-07-12

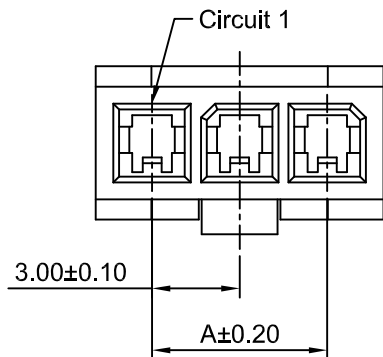

**Ordering Information:**

HDGC3030HMA-XP - \*\*  
1 2

1.Part No.

2.Material:

(blank):Nylon 66 UL94V-0

GWT:Nylon 66 UL94V-0,GWT 750°C

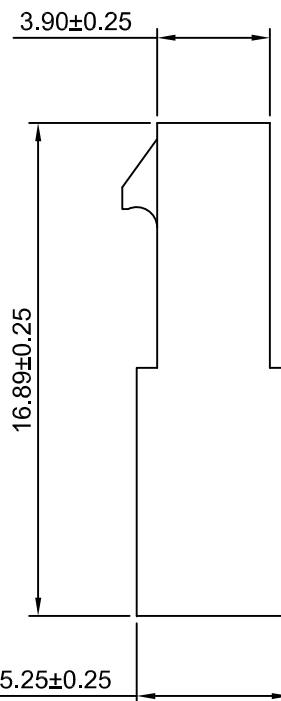
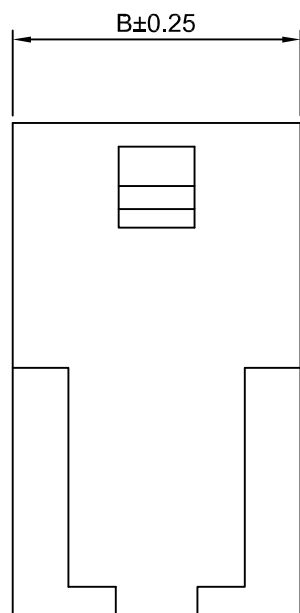
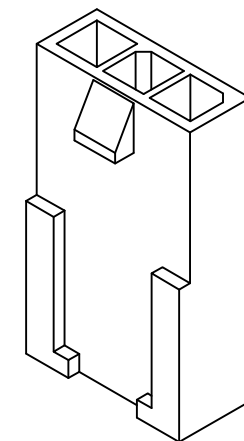

**SPECIFICATIONS:**

Current Rating: 5A AC,DC

Voltage Rating: 250V AC,DC

Temperature Range: -25°C ~ +85°C

Contact Resistance: 10mΩ Max

Insulation Resistance: 1000MΩ Min

Withstanding Voltage: 1500V AC/minute

Material: Nylon 66,UL94V-0(Black)

**Ordering Information & Dimensions**

Circuits	Dimensions(mm)		Circuits	Dimensions(mm)	
	A	B		A	B
2P	3.00	6.85	8P	21.00	24.85
3P	6.00	9.85	9P	24.00	27.85
4P	9.00	12.85	10P	27.00	30.85
5P	12.00	15.85	11P	30.00	33.85
6P	15.00	18.85	12P	33.00	36.85
7P	18.00	21.85			



**深圳市华德共创科技有限公司**

SHENZHEN HUADE CO-CREATE TECHNOLOGY CO.,LTD

TEL : 0755-27129737 FAX : 0755-29940187

-TOLERANCES- UNLESS OTHERWISE SPECIFIED 公差参数表						TITLE: 3.00mm Pitch Housing 产品名称:			
X.X	±0.30	X.X°	±3°	APPD: 核准:	XIE	PART NO: 产品编号: HDGC3030HMA-XP			
X.XX	±0.30	X.XX°	±2°	CHECK: 校对:	WANG	DATE	SCALE	UNIT	CODE NUMBER
X.XXX	±0.10	X.XXX°	±1°	DRAW: 绘图:	WANG	2015-07-12	4:1	mm	A008

修订 REV	标记 MARK	修改摘要 REVISION DESCRIPTION	签名 SIGNATURE	日期 DATE
AO		NEW RELEASE	WANG	2015-07-12

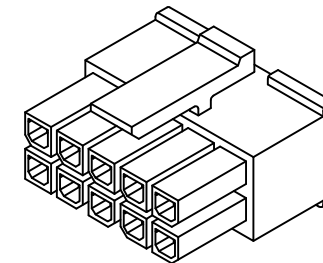
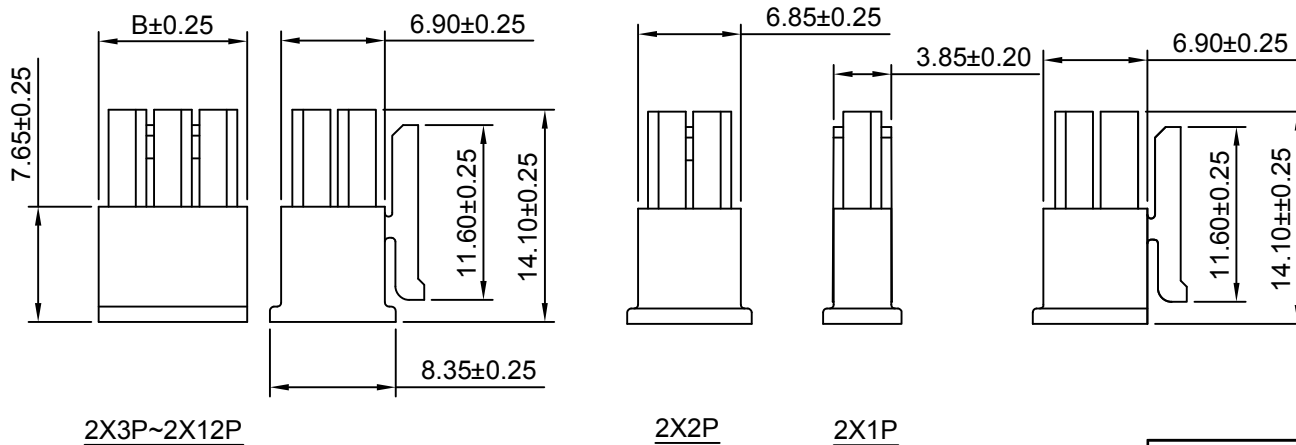
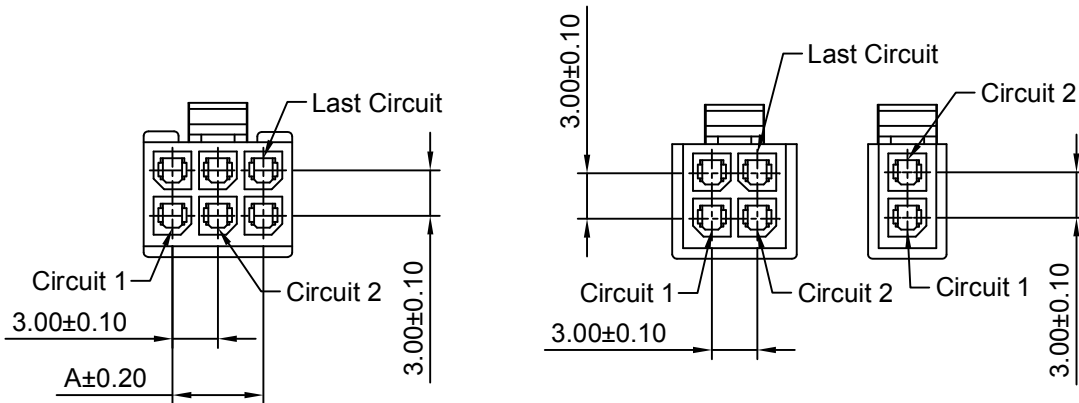

**Ordering Information:**

HDGC3030HF-2xXP - \*\*  
1 2

1.Part No.

2.Material:

(blank):Nylon 66 UL94V-0

GWT:Nylon 66 UL94V-0,GWT 750°C

**SPECIFICATIONS:**

Current Rating: 5A AC,DC

Voltage Rating: 250V AC,DC

Temperature Range: -25°C ~ +85°C

Contact Resistance: 10mΩ Max

Insulation Resistance: 1000MΩ Min

Withstanding Voltage: 1500V AC/minute

Material: Nylon 66,UL94V-0 (Black)

**Ordering Information & Dimensions**

Circuits	Dimensions(mm)		Circuits	Dimensions(mm)	
	A	B		A	B
2x1P	----	3.85	2x7P	18.00	21.85
2x2P	3.00	6.85	2x8P	21.00	24.85
2x3P	6.00	9.85	2x9P	24.00	27.85
2x4P	9.00	12.85	2x10P	27.00	30.85
2x5P	12.00	15.85	2x11P	30.00	33.85
2x6P	15.00	18.85	2x12P	33.00	36.85



**深圳市华德共创科技有限公司**

SHENZHEN HUADE CO-CREATE TECHNOLOGY CO.,LTD

TEL : 0755-27129737 FAX : 0755-29940187

-TOLERANCES- UNLESS OTHERWISE SPECIFIED 公差参数表						TITLE: 3.00mm Pitch Housing 产品名称:			
X.X	±0.30	X.X°	±3°	APPD: 核准:	XIE	PART NO: 产品编号: HDGC3030HF-2xXP			
X.XX	±0.30	X.XX°	±2°	CHECK: 校对:	WANG	DATE	SCALE	UNIT	CODE NUMBER
X.XXX	±0.10	X.XXX°	±1°	DRAW: 绘图:	WANG	2015-07-12	2:1	mm	A008

修订 REV	标记 MARK	修改摘要 REVISION DESCRIPTION	签名 SIGNATURE	日期 DATE
AO		NEW RELEASE	WANG	2015-07-12

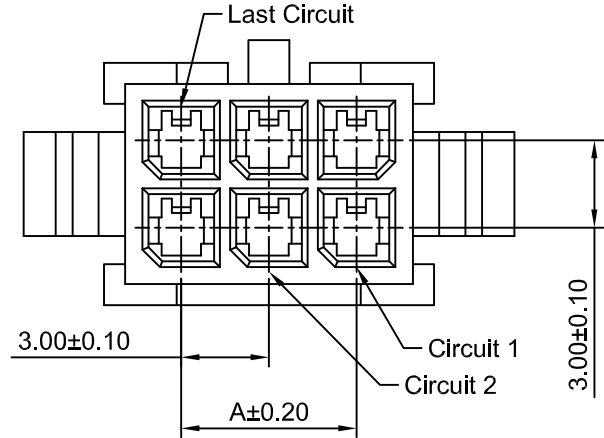

**Ordering Information:**  
**HDGC3030HM-2xXP - \*\***  
 1                      2

1.Part No.  
 2.Material:  
 (blank):Nylon 66 UL94V-0  
 GWT:Nylon 66 UL94V-0,GWT 750°C

HDGCC3030HMA-XP

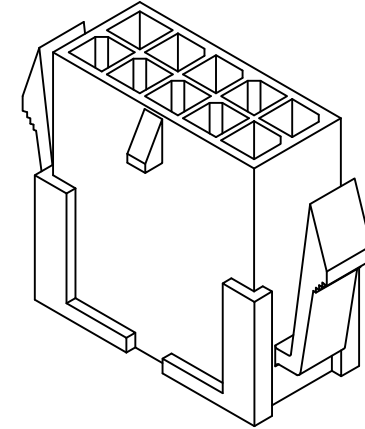
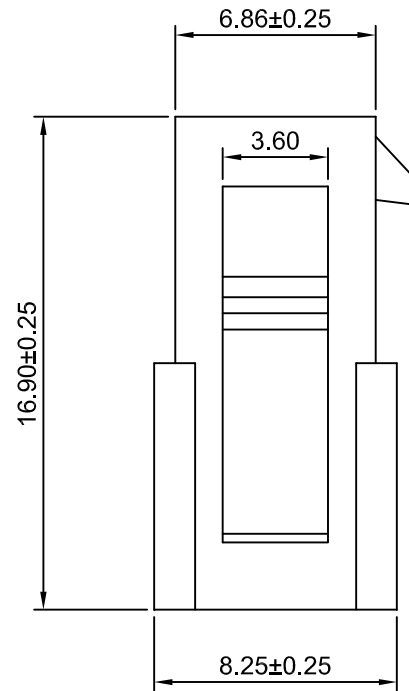
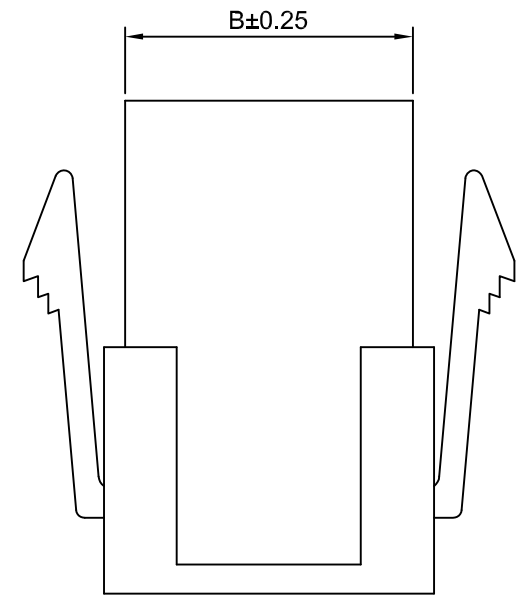

**SPECIFICATIONS:**

Current Rating: 5A AC,DC  
 Voltage Rating: 250V AC,DC  
 Temperature Range: -25°C ~ +85°C  
 Contact Resistance: 10mΩ Max  
 Insulation Resistance: 1000MΩ Min  
 Withstanding Voltage: 1500V AC/minute  
 Material: Nylon 66,UL94V-0(Black)

**Ordering Information & Dimensions**

Circuits	Dimensions(mm)		Circuits	Dimensions(mm)	
	A	B		A	B
2x1P	----	3.85	2x7P	18.00	21.85
2x2P	3.00	6.85	2x8P	21.00	24.85
2x3P	6.00	9.85	2x9P	24.00	27.85
2x4P	9.00	12.85	2x10P	27.00	30.85
2x5P	12.00	15.85	2x11P	30.00	33.85
2x6P	15.00	18.85	2x12P	33.00	36.85



**深圳市华德共创科技有限公司**

SHENZHEN HUADE CO-CREATE TECHNOLOGY CO.,LTD

TEL : 0755-27129737 FAX : 0755-29940187

-TOLERANCES- UNLESS OTHERWISE SPECIFIED 公差参数表						TITLE: 3.00mm Pitch Housing 产品名称:			
X.X	±0.30	X.X°	±3°	APPD: 核准:	XIE	PART NO: 产品编号: HDGC3030HM-2xXP			
X.XX	±0.30	X.XX°	±2°	CHECK: 校对:	WANG	DATE	SCALE	UNIT	CODE NUMBER
X.XXX	±0.10	X.XXX°	±1°	DRAW: 绘图:	WANG	2015-07-12	4:1	mm	A008

修订 REV	标记 MARK	修改摘要 REVISION DESCRIPTION	签名 SIGNATURE	日期 DATE
AO		NEW RELEASE	WANG	2015-07-12

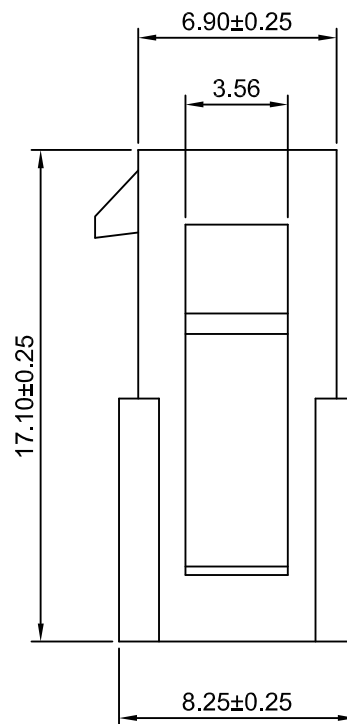
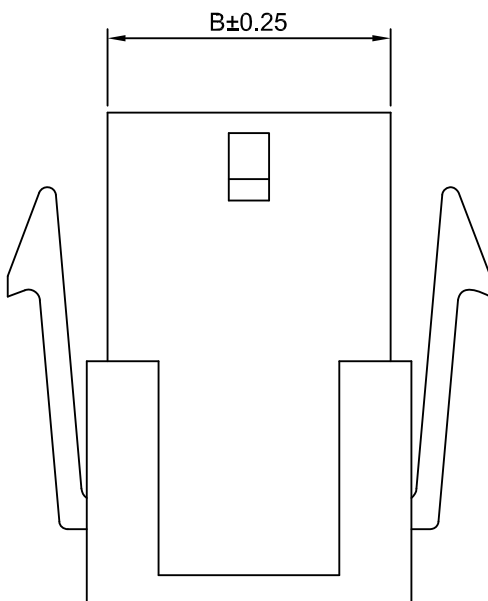
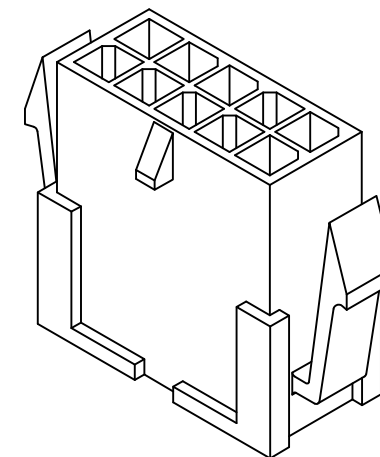
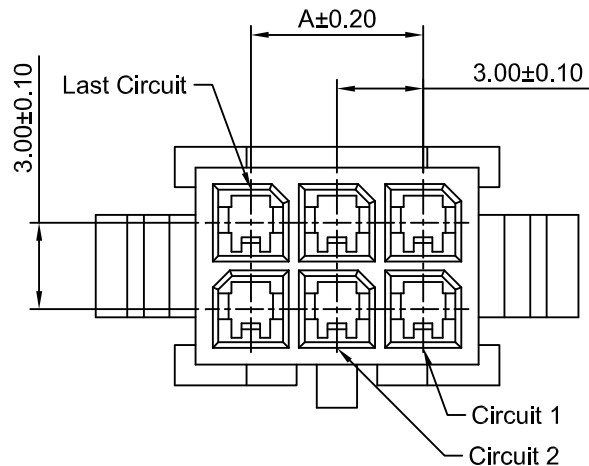

**SPECIFICATIONS:**

Current Rating: 5A AC,DC  
Voltage Rating: 250V AC,DC  
Temperature Range: -25°C ~ +85°C  
Contact Resistance: 10mΩ Max  
Insulation Resistance: 1000MΩ Min  
Withstanding Voltage: 1500V AC/minute  
Material: Nylon 66,UL94V-0 (Black)

**Ordering Information & Dimensions**

Circuits	Dimensions(mm)		Circuits	Dimensions(mm)	
	A	B		A	B
2x1P	----	3.85	2x7P	18.00	21.85
2x2P	3.00	6.85	2x8P	21.00	24.85
2x3P	6.00	9.85	2x9P	24.00	27.85
2x4P	9.00	12.85	2x10P	27.00	30.85
2x5P	12.00	15.85	2x11P	30.00	33.85
2x6P	15.00	18.85	2x12P	33.00	36.85



**深圳市华德共创科技有限公司**

SHENZHEN HUADE CO-CREATE TECHNOLOGY CO.,LTD

TEL : 0755-27129737 FAX : 0755-29940187

-TOLERANCES- UNLESS OTHERWISE SPECIFIED 公差参数表					TITLE: 3.00mm Pitch Housing 产品名称:			
X.X	±0.30	X.X° ±3°	APPD: 核准:	XIE	PART NO: 产品编号: HDGC3030HM-2xXP-A			
X.XX	±0.30	X.XX° ±2°	CHECK: 校对:	WANG	DATE	SCALE	UNIT	CODE NUMBER
X.XXX	±0.10	X.XXX° ±1°	DRAW: 绘图:	WANG	2015-07-12	4:1	mm	A008

修订 REV	标记 MARK	修改摘要 REVISION DESCRIPTION	签名 SIGNATURE	日期 DATE
AO		NEW RELEASE	WANG	2015-07-12

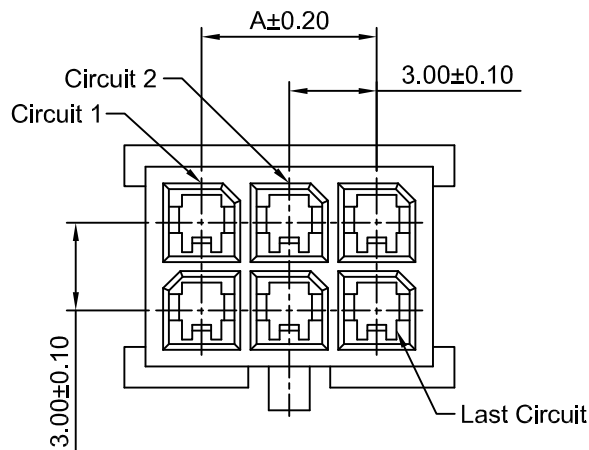

Ordering Information:  
 HDGC3030HMA-2xXP - \*\*  
 1 2

1.Part No.  
 2.Material:  
 (blank):Nylon 66 UL94V-0  
 GWT:Nylon 66 UL94V-0,GWT 750°C

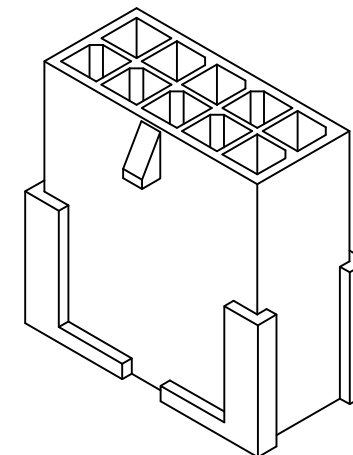

**SPECIFICATIONS:**

Current Rating: 5A AC,DC  
 Voltage Rating: 250V AC,DC  
 Temperature Range: -25°C ~ +85°C  
 Contact Resistance: 10mΩ Max  
 Insulation Resistance: 1000MΩ Min  
 Withstanding Voltage: 1500V AC/minute  
 Material: Nylon 66,UL94V-0(Black)

**Ordering Information & Dimensions**

Circuits	Dimensions(mm)		Circuits	Dimensions(mm)	
	A	B		A	B
2x1P	---	3.85	2x7P	18.00	21.85
2x2P	3.00	6.85	2x8P	21.00	24.85
2x3P	6.00	9.85	2x9P	24.00	27.85
2x4P	9.00	12.85	2x10P	27.00	30.85
2x5P	12.00	15.85	2x11P	30.00	33.85
2x6P	15.00	18.85	2x12P	33.00	36.85

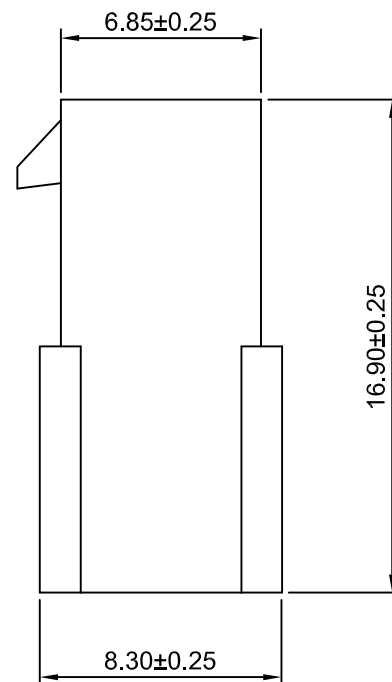
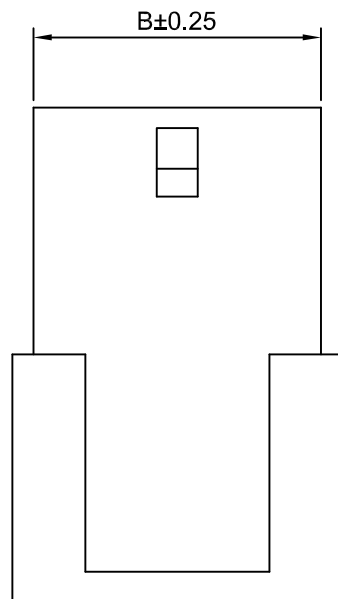

深圳市华德共创科技有限公司

SHENZHEN HUADE CO-CREATE TECHNOLOGY CO.,LTD

TEL : 0755-27129737 FAX : 0755-29940187

-TOLERANCES- UNLESS OTHERWISE SPECIFIED 公差参数表						TITLE: 3.00mm Pitch Housing 产品名称:			
X.X	$\pm 0.30$	X.X°	$\pm 3^\circ$	APPD: 核准:	XIE	PART NO: HDGC3030HMA-2xXP 产品编号:			
X.XX	$\pm 0.30$	X.XX°	$\pm 2^\circ$	CHECK: 校对:	WANG	DATE	SCALE	UNIT	CODE NUMBER
X.XXX	$\pm 0.10$	X.XXX°	$\pm 1^\circ$	DRAW: 绘图:	WANG	2015-07-12	4:1	mm	A008

修订 REV	标记 MARK	修改摘要 REVISION DESCRIPTION	签名 SIGNATURE	日期 DATE
AO		NEW RELEASE	WANG	2015-07-12

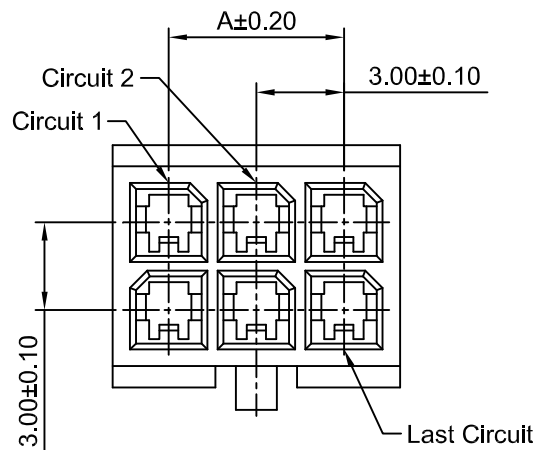

**Ordering Information:**

HDGC3030HMC-2xXP - \*\*  
1 2

1.Part No.

2.Material:

(blank):Nylon 66 UL94V-0

GWT:Nylon 66 UL94V-0,GWT 750°C

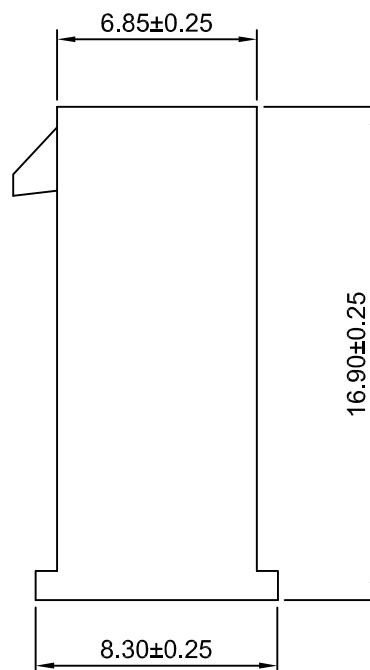
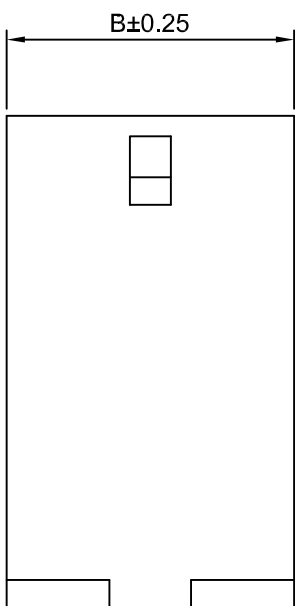
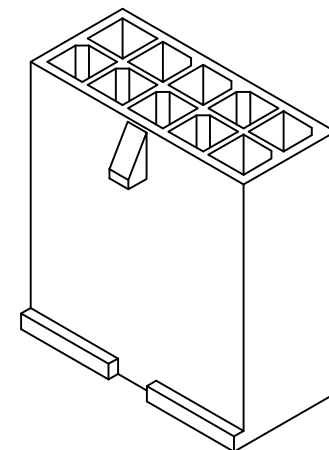

**SPECIFICATIONS:**

Current Rating: 5A AC,DC

Voltage Rating: 250V AC,DC

Temperature Range: -25°C ~ +85°C

Contact Resistance: 10mΩ Max

Insulation Resistance: 1000MΩ Min

Withstanding Voltage: 1500V AC/minute

Material: Nylon 66,UL94V-0(Black)

**Ordering Information & Dimensions**

Circuits	Dimensions(mm)		Circuits	Dimensions(mm)	
	A	B		A	B
2x1P	----	3.85	2x7P	18.00	21.85
2x2P	3.00	6.85	2x8P	21.00	24.85
2x3P	6.00	9.85	2x9P	24.00	27.85
2x4P	9.00	12.85	2x10P	27.00	30.85
2x5P	12.00	15.85	2x11P	30.00	33.85
2x6P	15.00	18.85	2x12P	33.00	36.85



深圳市华德共创科技有限公司

SHENZHEN HUADE CO-CREATE TECHNOLOGY CO.,LTD

TEL : 0755-27129737 FAX : 0755-29940187

-TOLERANCES- UNLESS OTHERWISE SPECIFIED 公差参数表					TITLE: 3.00mm Pitch Housing 产品名称:			
X.X	±0.30	X.X° ±3°	APPD: 核准:	XIE	PART NO: HDGC3030HMC-2xXP 产品编号:			
X.XX	±0.30	X.XX° ±2°	CHECK: 校对:	WANG	DATE	SCALE	UNIT	CODE NUMBER
X.XXX	±0.10	X.XXX° ±1°	DRAW: 绘图:	WANG	2015-07-12	4:1	mm	A008

修订 REV	标记 MARK	修改摘要 REVISION DESCRIPTION	签名 SIGNATURE	日期 DATE
AO		NEW RELEASE	WANG	2015-07-12

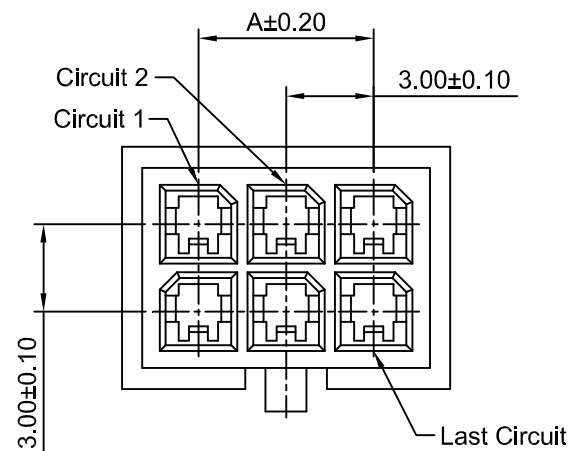

**Ordering Information:**

HDGC3030HMC-2xXP-A - \*\*  
1 2

1.Part No.

2.Material:

(blank):Nylon 66 UL94V-0

GWT:Nylon 66 UL94V-0,GWT 750°C

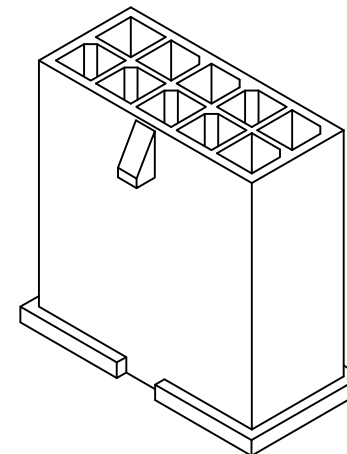

**SPECIFICATIONS:**

Current Rating: 5A AC,DC

Voltage Rating: 250V AC,DC

Temperature Range: -25°C ~ +85°C

Contact Resistance: 10mΩ Max

Insulation Resistance: 1000MΩ Min

Withstanding Voltage: 1500V AC/minute

Material: Nylon 66,UL94V-0(Black)

**Ordering Information & Dimensions**

Circuits	Dimensions(mm)		Circuits	Dimensions(mm)	
	A	B		A	B
2x1P	----	3.85	2x7P	18.00	21.85
2x2P	3.00	6.85	2x8P	21.00	24.85
2x3P	6.00	9.85	2x9P	24.00	27.85
2x4P	9.00	12.85	2x10P	27.00	30.85
2x5P	12.00	15.85	2x11P	30.00	33.85
2x6P	15.00	18.85	2x12P	33.00	36.85

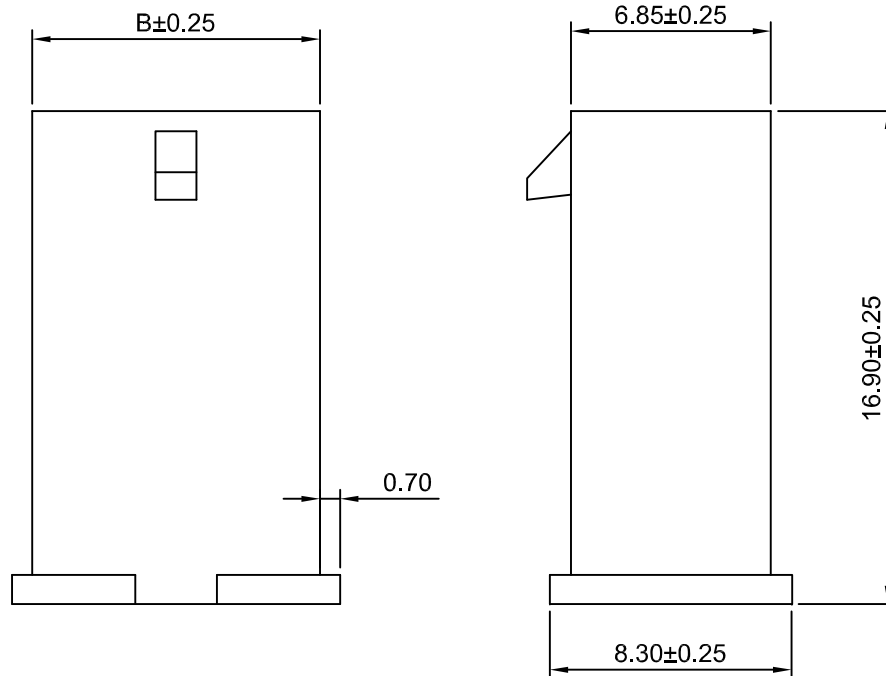

**深圳市华德共创科技有限公司**  
SHENZHEN HUADE CO-CREATE TECHNOLOGY CO.,LTD  
TEL : 0755-27129737 FAX : 0755-29940187

-TOLERANCES- UNLESS OTHERWISE SPECIFIED 公差参数表				TITLE: 3.00mm Pitch Housing 产品名称: 3.00mm Pitch Housing			
X.X	±0.30	X.X° ±3°	APPD: 核准: XIE	PART NO: 产品编号: HDGC3030HMC-2xXP-A			
X.XX	±0.30	X.XX° ±2°	CHECK: 校对: WANG	DATE	SCALE	UNIT	CODE NUMBER
X.XXX	±0.10	X.XXX° ±1°	DRAW: 绘图: WANG	2015-07-12	4:1	mm	A008

修订 REV	标记 MARK	修改摘要 REVISION DESCRIPTION	签名 SIGNATURE	日期 DATE
A0		NEW RELEASE	WANG	2015-07-12
A1		CHANGE THE Current Rating	WANG	2018-12-14

**Ordering Information:**

HDGC3030HFB-2xXP - \*\*  
1 2

1.Part No.

2.Material:

(blank):Nylon 66 UL94V-0

GWT:Nylon 66 UL94V-0,GWT 750°C

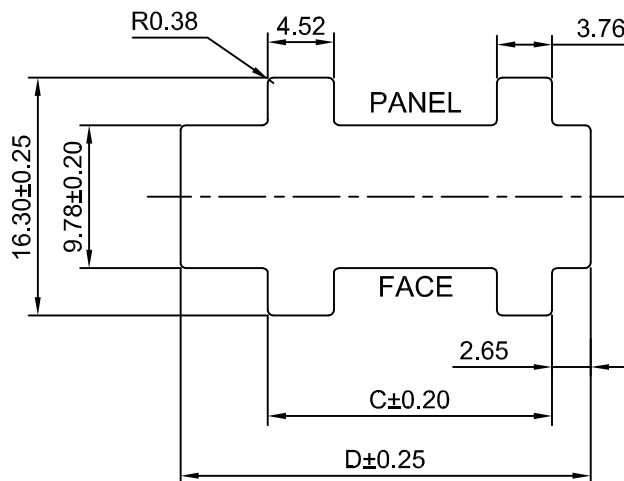
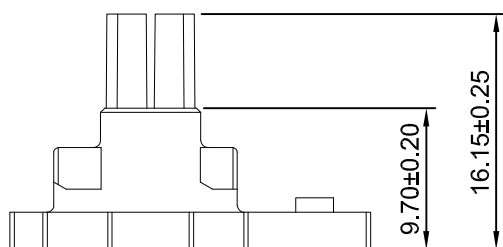
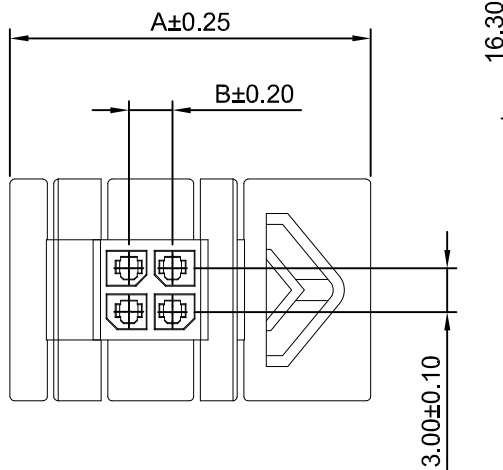

PANEL OPENING  
RECOMMENDED PANEL THICKNESS  
1.57/1.27

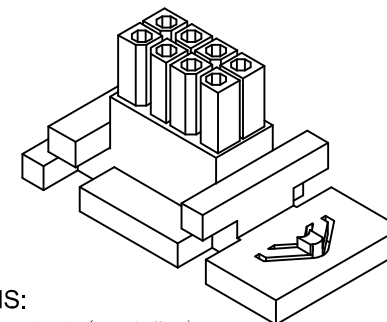
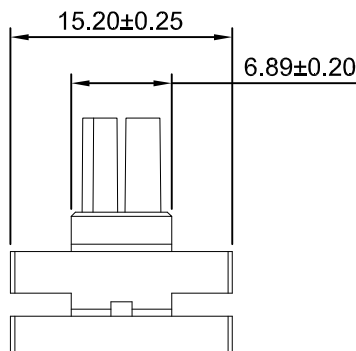

**SPECIFICATIONS:**

Current Rating: 8.5A AC,DC (AWG #18)

Voltage Rating: 250V AC,DC

Temperature Range: -25°C ~ +85°C

Contact Resistance: 10mΩ Max

Insulation Resistance: 1000MΩ Min

Withstanding Voltage: 1500V AC/minute

Material: Nylon 66,UL94V-0(Black)

**Ordering Information & Dimensions**

Circuits	Dimensions(mm)			
	A	B	C	D
2x2P	24.70	3.00	13.46	22.10
2x3P	27.70	6.00	16.46	25.10
2x4P	30.70	9.00	19.46	28.10
2x5P	33.70	12.00	22.46	31.10
2x6P	36.70	15.00	25.46	34.10
2x7P	39.70	18.00	28.46	37.10
2x8P	42.70	21.00	31.46	40.10
2x9P	45.70	24.00	34.46	43.10
2x10P	48.70	27.00	37.46	46.10
2x11P	51.70	30.00	40.46	49.10
2x12P	54.70	33.00	43.46	52.10



深圳市华德共创科技有限公司

SHENZHEN HUADE CO-CREATE TECHNOLOGY CO.,LTD

TEL : 0755-27129737 FAX : 0755-29940187

-TOLERANCES- UNLESS OTHERWISE SPECIFIED 公差参数表				TITLE: 产品名称: 3.00mm Pitch Housing				
X.X	±0.30	X.X°	±3°	APPD: 核准: XIE	PART NO: 产品编号: HDGC3030HFB-2xXP			
X.XX	±0.30	X.XX°	±2°	CHECK: 校对: WANG	DATE	SCALE	UNIT	CODE NUMBER
X.XXX	±0.10	X.XXX°	±1°	DRAW: 绘图: WANG	2018-12-14	2:1	mm	A008

修订 REV	标记 MARK	修改摘要 REVISION DESCRIPTION	签名 SIGNATURE	日期 DATE
AO		NEW RELEASE	WANG	2015-07-12

Ordering Information:  
 HDGC3030HMB-2xXP - \*\*  
 1 2

1.Part No.  
 2.Material:  
 (blank):Nylon 66 UL94V-0  
 GWT:Nylon 66 UL94V-0,GWT 750°C

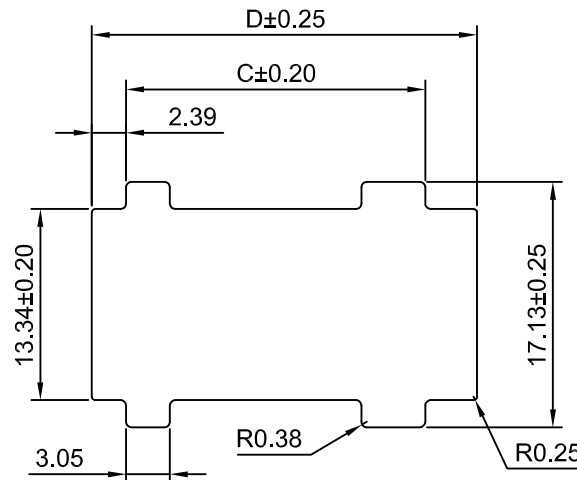
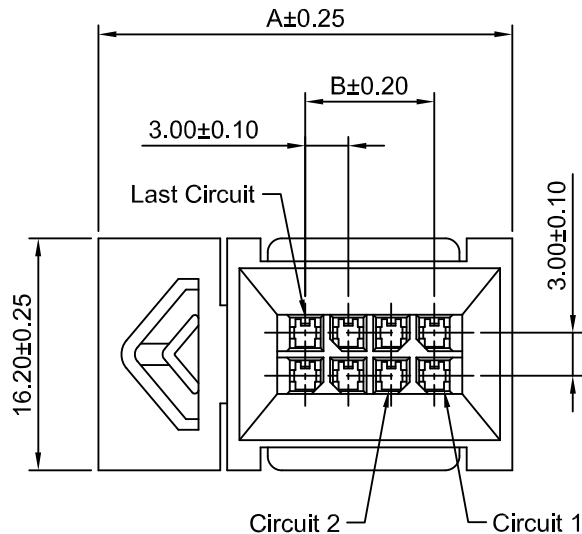
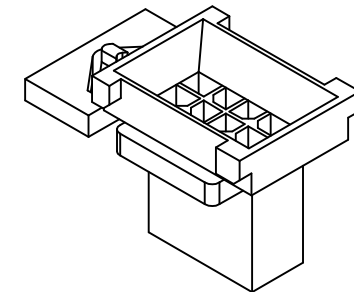

PANEL OPENING  
 RECOMMENDED PANEL THICKNESS  
 1.57/1.27

**SPECIFICATIONS:**

Current Rating: 5A AC,DC  
 Voltage Rating: 250V AC,DC  
 Temperature Range: -25°C ~ +85°C  
 Contact Resistance: 10mΩ Max  
 Insulation Resistance: 1000MΩ Min  
 Withstanding Voltage: 1500V AC/minute  
 Material: Nylon 66,UL94V-0(Black)

Ordering Information & Dimensions

Circuits	Dimensions(mm)			
	A	B	C	D
2x2P	22.84	3.00	14.85	20.85
2x3P	25.84	6.00	17.85	23.85
2x4P	28.84	9.00	20.85	26.85
2x5P	31.84	12.00	23.85	29.85
2x6P	34.84	15.00	26.85	32.85
2x7P	37.84	18.00	29.85	35.85
2x8P	40.84	21.00	32.85	38.85
2x9P	43.84	24.00	35.85	41.85
2x10P	46.84	27.00	38.85	44.85
2x11P	49.84	30.00	41.85	47.85
2x12P	52.84	33.00	44.85	50.85

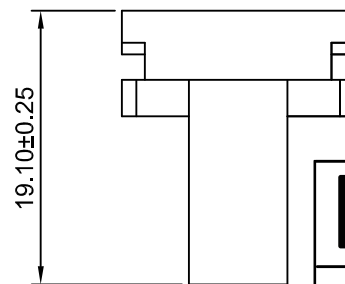
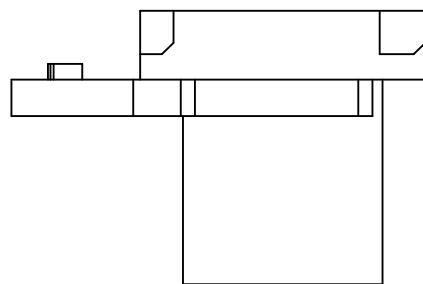

**HDGC** 深圳市华德共创科技有限公司  
 SHENZHEN HUADE CO-CREATE TECHNOLOGY CO.,LTD  
 TEL : 0755-27129737 FAX : 0755-29940187

-TOLERANCES- UNLESS OTHERWISE SPECIFIED 公差参数表						TITLE: 3.00mm Pitch Housing 产品名称:			
X.X	±0.30	X.X°	±3°	APPD: 核准:	XIE	PART NO: 产品编号: HDGC3030HMB-2xXP			
X.XX	±0.30	X.XX°	±2°	CHECK: 校对:	WANG	DATE	SCALE	UNIT	CODE NUMBER
X.XXX	±0.10	X.XXX°	±1°	DRAW: 绘图:	WANG	2015-07-12	2:1	mm	A008

修订 REV	标记 MARK	修改摘要 REVISION DESCRIPTION	签名 SIGNATURE	日期 DATE
AO		NEW RELEASE	WANG	2015-07-12

Ordering Information:

HDGC3030WV-XP - \* - \*\*\* - \*\*\*  
1 2 3 4

- Part No.
- Style:  
(blank):Type 1  
2:Type 2
- Material:  
(blank):Nylon 66, UL94V-0  
LCP:LCP, UL94V-0  
GWT:LCP, UL94V-0,GWT 750°C
- Finish:  
(blank):Tin over Nickel  
G:Gold over Nickel(1"U)  
G3:Gold over Nickel(3"U)  
G15:Gold over Nickel(15"U)  
G30:Gold over Nickel(30"U)

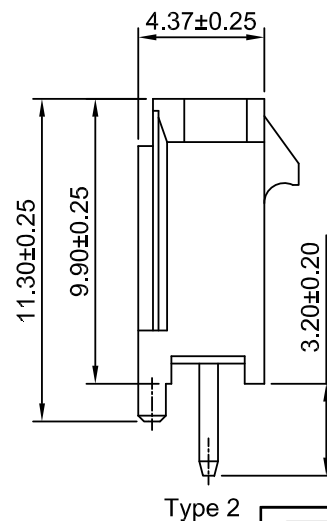
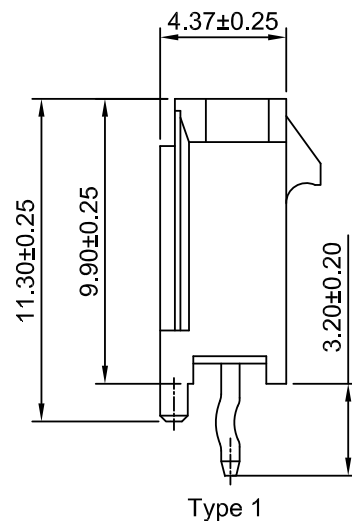
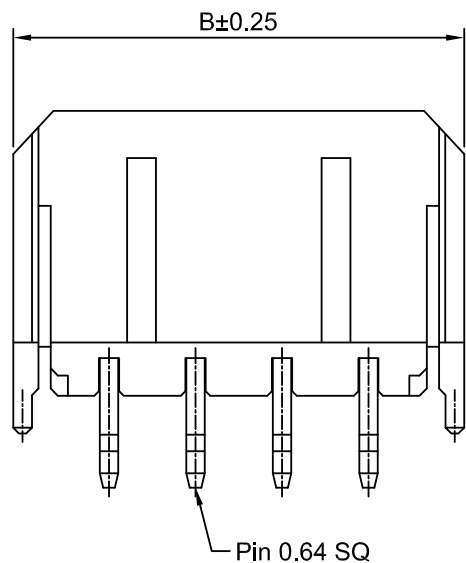
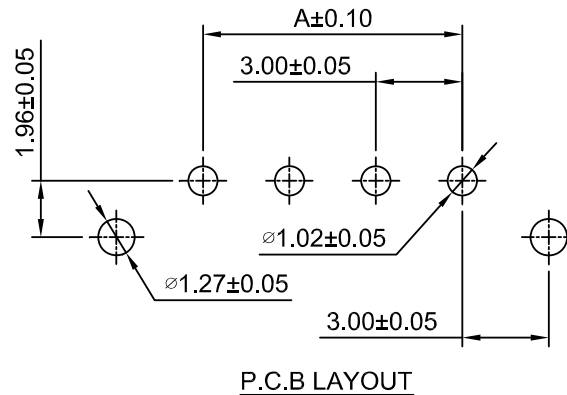
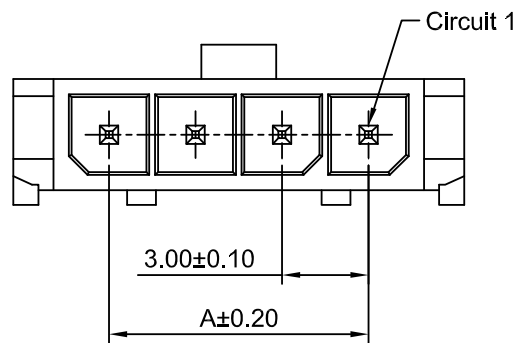
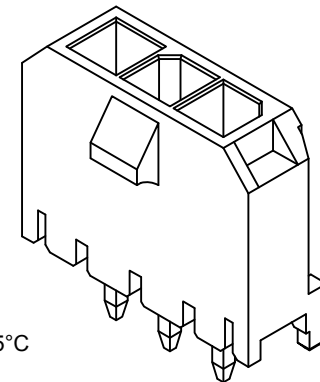

SPECIFICATIONS:

Current Rating: 5A AC,DC  
Voltage Rating: 250V AC,DC  
Temperature Range: -25°C ~ +85°C  
Contact Resistance: 10mΩ Max  
Insulation Resistance: 1000MΩ Min  
Withstanding Voltage: 1500V AC/minute  
Pin Material:Brass/Tin over Nickel  
Material: Nylon 66,UL94V-0(Black)

Ordering Information & Dimensions

Circuits	Dimensions(mm)		Circuits	Dimensions(mm)	
	A	B		A	B
2P	3.00	9.65	8P	21.00	27.65
3P	6.00	12.65	9P	24.00	30.65
4P	9.00	15.65	10P	27.00	33.65
5P	12.00	18.65	11P	30.00	36.65
6P	15.00	21.65	12P	33.00	39.65
7P	18.00	24.65			



深圳市华德共创科技有限公司

SHENZHEN HUADE CO-CREATE TECHNOLOGY CO.,LTD

TEL : 0755-27129737 FAX : 0755-29940187

-TOLERANCES- UNLESS OTHERWISE SPECIFIED 公差参数表				TITLE: 产品名称: 3.00mm Pitch 180° Wafer	
X.X	±0.30	X.X°	±3°	APPD: 核准:	XIE
X.XX	±0.30	X.XX°	±2°	CHECK: 校对:	WANG
X.XXX	±0.10	X.XXX°	±1°	DRAW: 绘图:	WANG
PART NO: 产品编号:		HDGC3030WV-XP			
DATE	SCALE	UNIT	CODE NUMBER		
2015-07-12	4:1	mm	A008		

修订 REV	标记 MARK	修改摘要 REVISION DESCRIPTION	签名 SIGNATURE	日期 DATE
AO		NEW RELEASE	WANG	2015-07-12

Ordering Information:  
 HDGC3030WR-XP - \*\* - \*\*  
 1 2 3

- Part No.
- Material:  
 (blank):Nylon 66 UL94V-0  
 LCP:LCP UL94V-0  
 GWT:Nylon 66 UL94V-0,GWT 750°C
- Finish:  
 (blank):Tin over Nickel  
 G:Gold over Nickel(1"U)  
 G3:Gold over Nickel(3"U)  
 G15:Gold over Nickel(15"U)  
 G30:Gold over Nickel(30"U)

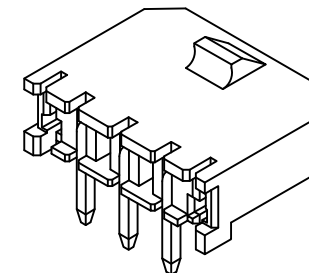

SPECIFICATIONS:  
 Current Rating: 5A AC,DC  
 Voltage Rating: 250V AC,DC  
 Temperature Range: -25°C ~ +85°C  
 Contact Resistance: 10mΩ Max  
 Insulation Resistance: 1000MΩ Min  
 Withstanding Voltage: 1500V AC/minute  
 Pin Material:Brass/Tin over Nickel  
 Material: Nylon 66,UL94V-0(Black)

Ordering Information & Dimensions

Circuits	Dimensions(mm)		Circuits	Dimensions(mm)	
	A	B		A	B
2P	3.00	9.65	8P	21.00	27.65
3P	6.00	12.65	9P	24.00	30.65
4P	9.00	15.65	10P	27.00	33.65
5P	12.00	18.65	11P	30.00	36.65
6P	15.00	21.65	12P	33.00	39.65
7P	18.00	24.65			

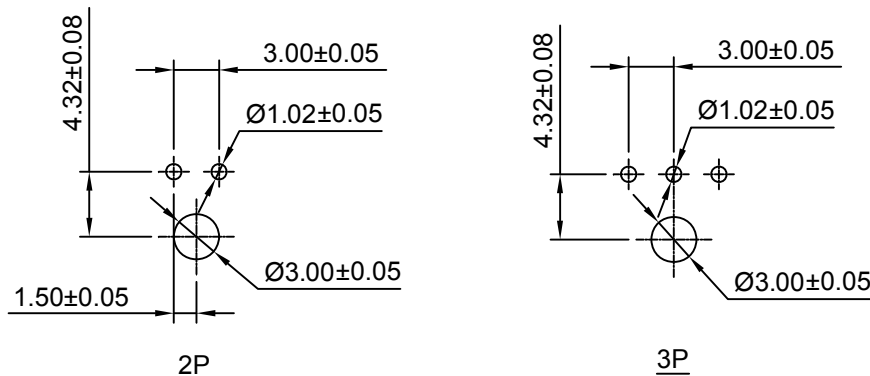

P.C.B LAYOUT

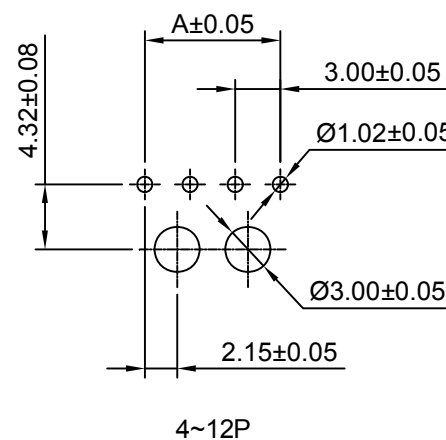
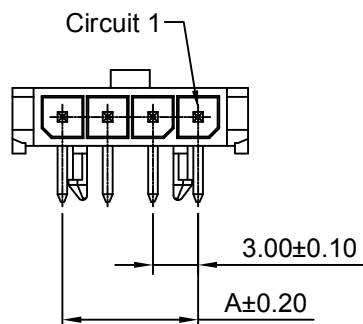

P.C.B LAYOUT

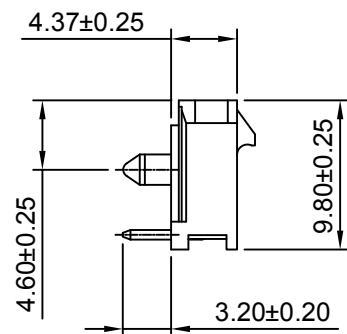
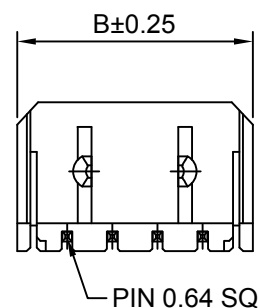

深圳市华德共创科技有限公司

SHENZHEN HUADE CO-CREATE TECHNOLOGY CO.,LTD

TEL : 0755-27129737 FAX : 0755-29940187

-TOLERANCES- UNLESS OTHERWISE SPECIFIED 公差参数表				TITLE: 产品名称 : 3.00mm Pitch 90° Wafer	
X.X	±0.30	X.X°	±3°	APPD: 核准 :	XIE
X.XX	±0.30	X.XX°	±2°	CHECK: 校对 :	WANG
X.XXX	±0.10	X.XXX°	±1°	DRAW: 绘图 :	WANG
PART NO: 产品编号 :			HDGC3030WR-XP		
DATE	SCALE	UNIT	CODE NUMBER		
2015-07-12	2:1	mm	A008		

修订 REV	标记 MARK	修改摘要 REVISION DESCRIPTION	签名 SIGNATURE	日期 DATE
AO		NEW RELEASE	WANG	2015-07-12

Ordering Information:  
 HDGC3030WV-F-XP - \*\*\* - \*\*\* - \*\*\*  
 1 2 3 4

- Part No.
- Size(H):  
 (blank):2.00mm  
 H30:3.00mm
- Material:  
 (blank):Nylon 66, UL94V-0  
 (blank):LCP, UL94V-0  
 GWT:LCP, UL94V-0,GWT 750°C
- Finish:  
 (blank):Tin over Nickel  
 G:Gold over Nickel(1"U)  
 G3:Gold over Nickel(3"U)  
 G15:Gold over Nickel(15"U)  
 G30:Gold over Nickel(30"U)

**SPECIFICATIONS:**

Current Rating: 5A AC,DC  
 Voltage Rating: 250V AC,DC  
 Temperature Range: -25°C ~ +85°C  
 Contact Resistance: 10mΩ Max  
 Insulation Resistance: 1000MΩ Min  
 Withstanding Voltage: 1500V AC/minute  
 Pin Material: Brass/Tin over Nickel  
 Material: Nylon 66,UL94V-0(Black)

Ordering Information & Dimensions

Circuits	Dimensions(mm)			Circuits	Dimensions(mm)		
	A	B	C		A	B	C
2P	3.00	9.65	7.30	8P	21.00	27.65	25.30
3P	6.00	12.65	10.30	9P	24.00	30.65	28.30
4P	9.00	15.65	13.30	10P	27.00	33.65	31.30
5P	12.00	18.65	16.30	11P	30.00	36.65	34.30
6P	15.00	21.65	19.30	12P	33.00	39.65	37.30
7P	18.00	24.65	22.30				

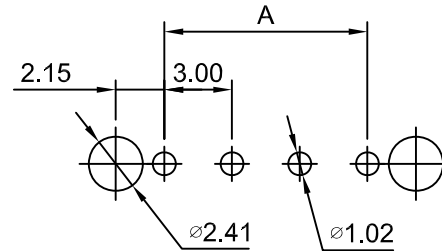
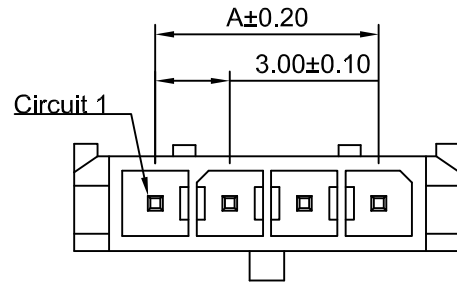

P.C.B LAYOUT

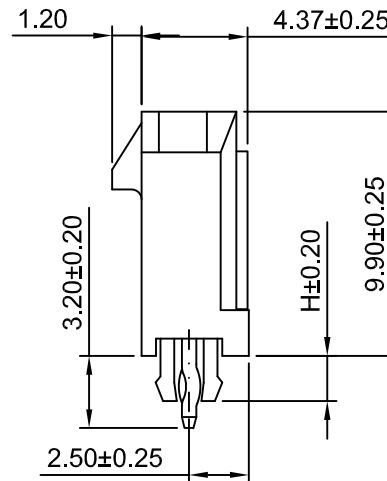
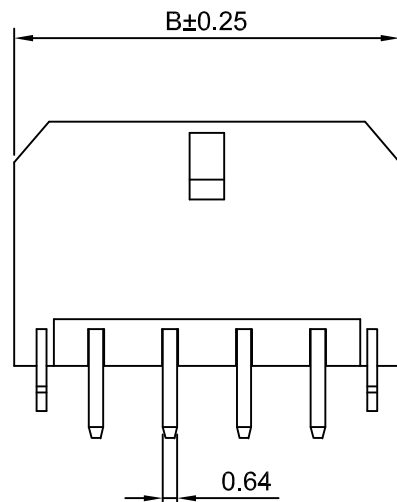

**HDGC** 深圳市华德共创科技有限公司  
 SHENZHEN HUADE CO-CREATE TECHNOLOGY CO.,LTD  
 TEL : 0755-27129737 FAX : 0755-29940187

-TOLERANCES- UNLESS OTHERWISE SPECIFIED 公差参数表				TITLE: 产品名称: 3.00mm Pitch 180° Wafer	
X.X	±0.30	X.X°	±3°	APPD: 核准:	XIE
X.XX	±0.30	X.XX°	±2°	CHECK: 校对:	WANG
X.XXX	±0.10	X.XXX°	±1°	DRAW: 绘图:	WANG
PART NO: 产品编号:		HDGC3030WV-F-XP			
DATE	SCALE	UNIT	CODE NUMBER		
2015-07-12	3:1	mm	A008		

修订 REV	标记 MARK	修改摘要 REVISION DESCRIPTION	签名 SIGNATURE	日期 DATE
AO		NEW RELEASE	WANG	2017-10-16

### Ordering Information:

HDGC3030WR-S-F-XP - \*\*\* - \*\*\* - \*\*\*  
1 2 3 4

- Part No.
- Size(H):  
(blank):2.00mm  
H30:3.00mm
- Material:  
(blank):Nylon 66 UL94V-0  
GWT:Nylon 66 UL94V-0,GWT 750°C
- Finish:  
(blank):Tin over Nickel  
G:Gold over Nickel(1"U)  
G3:Gold over Nickel(3"U)  
G15:Gold over Nickel(15"U)  
G30:Gold over Nickel(30"U)

### SPECIFICATIONS:

Current Rating: 5A AC,DC  
Voltage Rating: 250V AC,DC  
Temperature Range:-25°C ~ +85°C  
Contact Resistance: 10mΩ Max  
Insulation Resistance: 1000MΩ Min  
Withstanding Voltage: 1500V AC/minute  
Pin Material: Brass/Tin over Nickel  
Material: Nylon 66,UL94V-0(Black)

### Ordering Information & Dimensions

Circuits	Dimensions(mm)		Circuits	Dimensions(mm)	
	A	B		A	B
2P	3.00	9.65	8P	21.00	27.65
3P	6.00	12.65	9P	24.00	30.65
4P	9.00	15.65	10P	27.00	33.65
5P	12.00	18.65	11P	30.00	36.65
6P	15.00	21.65	12P	33.00	39.65
7P	18.00	24.65			

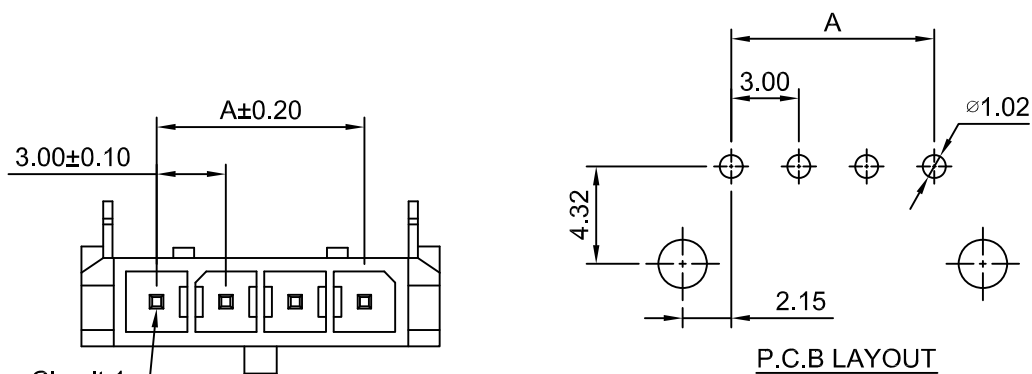

P.C.B LAYOUT

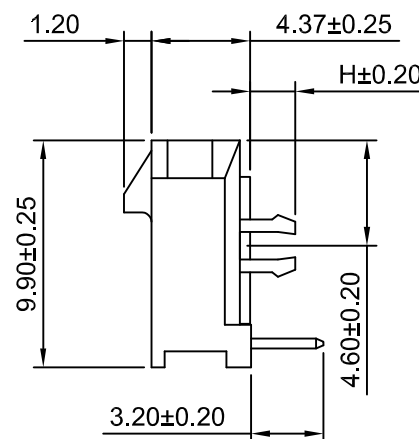
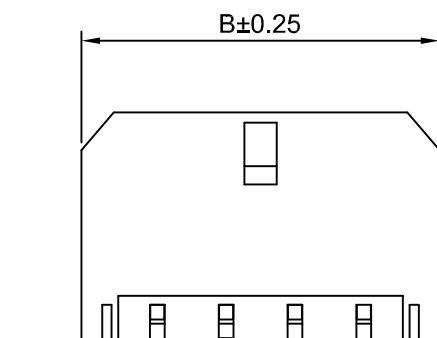

深圳市华德共创科技有限公司

SHENZHEN HUADE CO-CREATE TECHNOLOGY CO.,LTD

TEL : 0755-27129737 FAX : 0755-29940187

-TOLERANCES- UNLESS OTHERWISE SPECIFIED 公差参数表				TITLE: 产品名称: 3.00mm Pitch 90° Wafer	
X.X	±0.30	X.X°	±3°	APPD: 核准:	XIE
X.XX	±0.30	X.XX°	±2°	CHECK: 校对:	WANG
X.XXX	±0.10	X.XXX°	±1°	DRAW: 绘图:	WANG
PART NO: 产品编号:		HDGC3030WR-F-XP			
DATE	SCALE	UNIT	CODE NUMBER		
2017-10-16	3:1	mm	A008		

修订 REV	标记 MARK	修改摘要 REVISION DESCRIPTION	签名 SIGNATURE	日期 DATE
AO		NEW RELEASE	WANG	2015-07-12

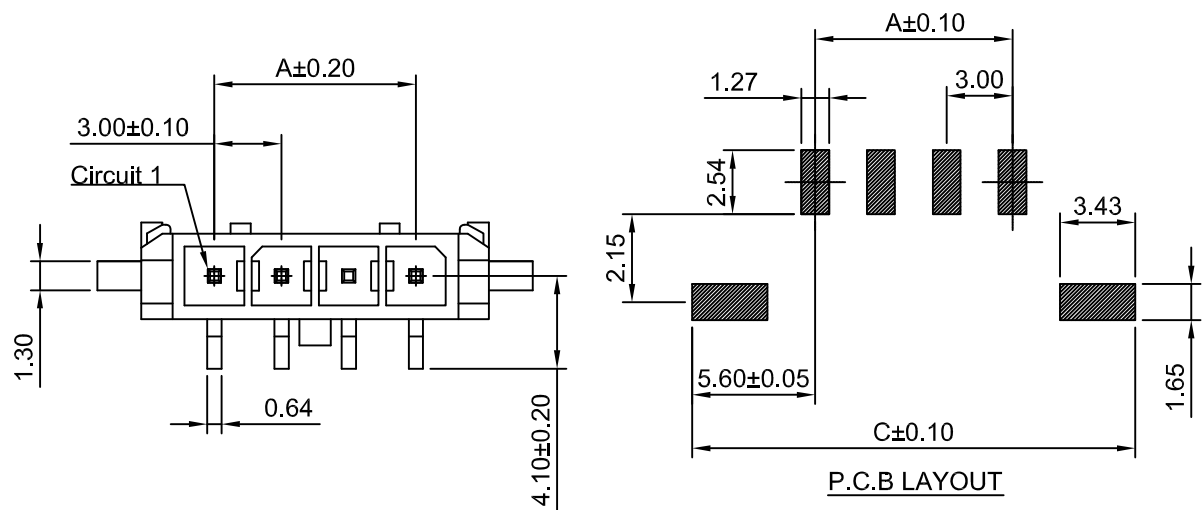

P.C.B LAYOUT

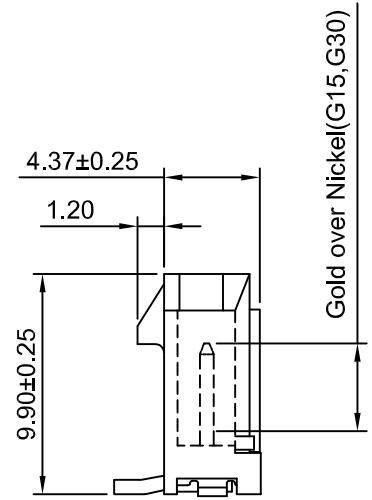
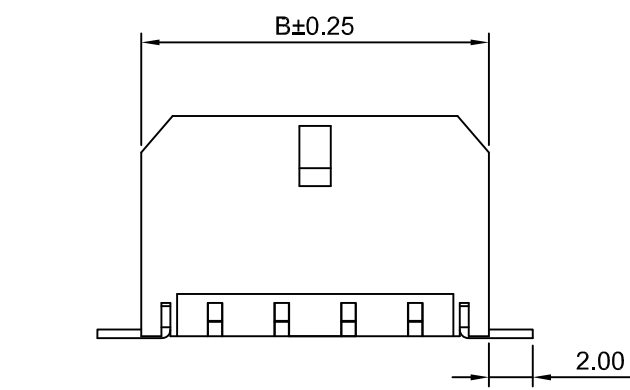

Ordering Information:  
 HDGC3030WV-S-XP - \*\* - \*\*  
 1 2 3

- Part No.
- Material:  
 (blank);LCP UL94V-0  
 GWT:LCP UL94V-0,GWT 750°C
- Finish:  
 (blank);Tin over Nickel  
 G:Gold over Nickel(1"U)  
 G15:Gold over Nickel(15"U)  
 G30:Gold over Nickel(30"U)

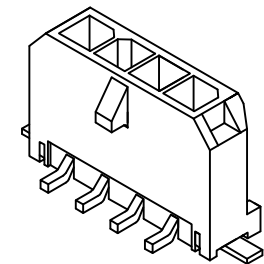

SPECIFICATIONS:

Current Rating: 5A AC,DC  
 Voltage Rating: 250V AC,DC  
 Temperature Range: -25°C ~ +85°C  
 Contact Resistance: 10mΩ Max  
 Insulation Resistance: 1000MΩ Min  
 Withstanding Voltage: 1500V AC/minute  
 Pin Material: Brass/Tin over Nickel  
 Material: LCP,UL94V-0 (Black)

Ordering Information & Dimensions

Circuits	Dimensions(mm)			Circuits	Dimensions(mm)		
	A	B	C		A	B	C
2P	3.00	9.65	14.20	8P	21.00	27.65	32.20
3P	6.00	12.65	17.20	9P	24.00	30.65	35.20
4P	9.00	15.65	20.20	10P	27.00	33.65	38.20
5P	12.00	18.65	23.20	11P	30.00	36.65	41.20
6P	15.00	21.65	26.20	12P	33.00	39.65	44.20
7P	18.00	24.65	29.20				

**HDGC** 深圳市华德共创科技有限公司  
 SHENZHEN HUADE CO-CREATE TECHNOLOGY CO.,LTD  
 TEL : 0755-27129737 FAX : 0755-29940187

-TOLERANCES- UNLESS OTHERWISE SPECIFIED 公差参数表						TITLE: 3.00mm Pitch 产品名称: 180° Wafer			
X.X	±0.30	X.X°	±3°	APPD: 核准:	XIE	PART NO: 产品编号: HDGC3030WV-S-XP			
X.XX	±0.30	X.XX°	±2°	CHECK: 校对:	WANG	DATE	SCALE	UNIT	CODE NUMBER
X.XXX	±0.10	X.XXX°	±1°	DRAW: 绘图:	WANG	2015-07-12	3:1	mm	A008

修订 REV	标记 MARK	修改摘要 REVISION DESCRIPTION	签名 SIGNATURE	日期 DATE
AO		NEW RELEASE	WANG	2015-07-12

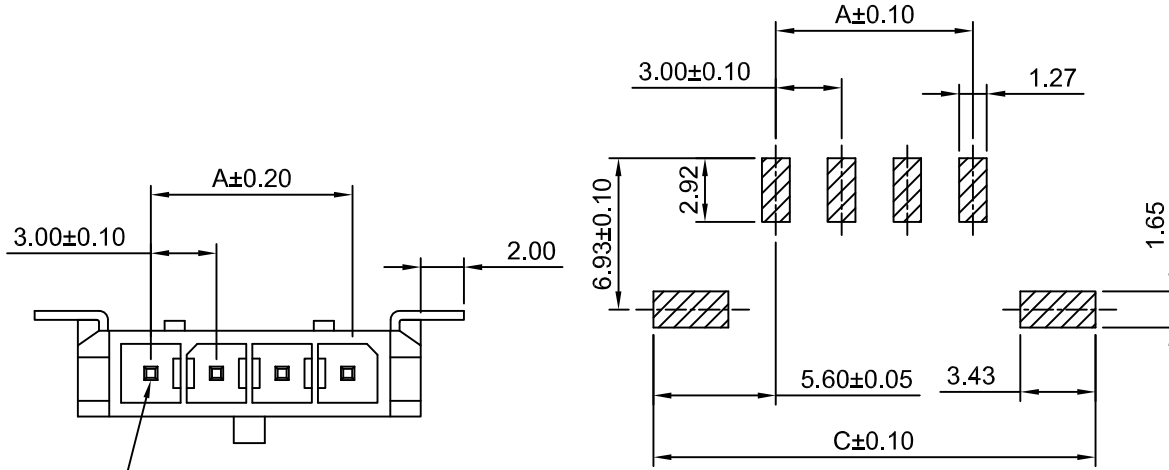

P.C.B LAYOUT

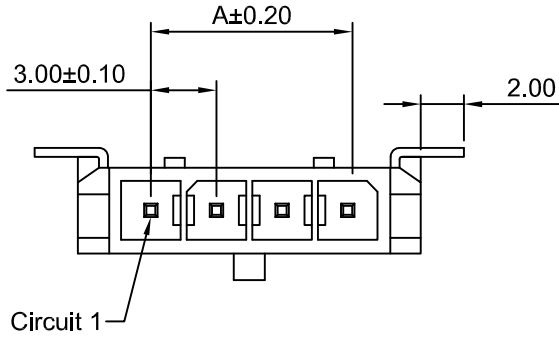

Circuit 1

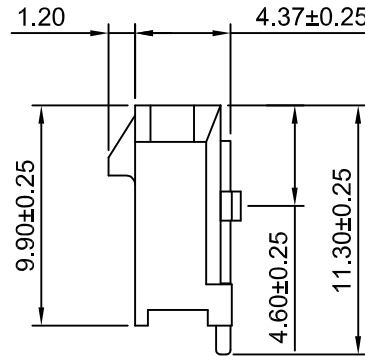
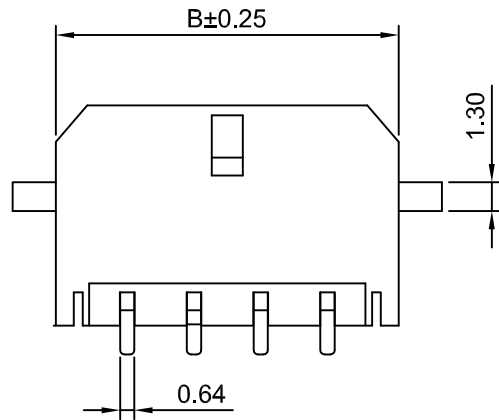

Ordering Information:

HDGC3030WR-S-XP - \*\* - \*\*  
1 2 3

- Part No.
- Material:  
(blank):LCP UL94V-0  
GWT:LCP UL94V-0,GWT 750°C
- Finish:  
(blank):Tin over Nickel  
G:Gold over Nickel(1"U)  
G3:Gold over Nickel(3"U)  
G15:Gold over Nickel(15"U)  
G30:Gold over Nickel(30"U)

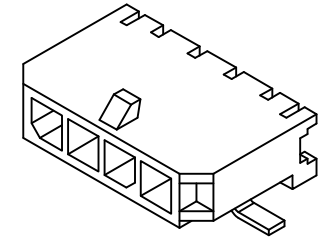

SPECIFICATIONS:

Current Rating: 5A AC,DC  
Voltage Rating: 250V AC,DC  
Temperature Range: -25°C ~ +85°C  
Contact Resistance: 10mΩ Max  
Insulation Resistance: 1000MΩ Min  
Withstanding Voltage: 1500V AC/minute  
Pin Material: Brass/Tin over Nickel  
Material: LCP,UL94V-0(Black)

Ordering Information & Dimensions

Circuits	Dimensions(mm)			Circuits	Dimensions(mm)		
	A	B	C		A	B	C
2P	3.00	9.65	14.20	8P	21.00	27.65	32.20
3P	6.00	12.65	17.20	9P	24.00	30.65	35.20
4P	9.00	15.65	20.20	10P	27.00	33.65	38.20
5P	12.00	18.65	23.20	11P	30.00	36.65	41.20
6P	15.00	21.65	26.20	12P	33.00	39.65	44.20
7P	18.00	24.65	29.20				



深圳市华德共创科技有限公司

SHENZHEN HUADE CO-CREATE TECHNOLOGY CO.,LTD

TEL : 0755-27129737 FAX : 0755-29940187

-TOLERANCES- UNLESS OTHERWISE SPECIFIED 公差参数表			TITLE: 产品名称 : 3.00mm Pitch 90° Wafer	
X.X	±0.30	X.X° ±3°	APPD: 核准 : XIE	PART NO: 产品编号 : HDGC3030WR-S-XP
X.XX	±0.30	X.XX° ±2°	CHECK: 校对 : WANG	DATE
X.XXX	±0.10	X.XXX° ±1°	DRAW: 绘图 : WANG	SCALE
				UNIT
				CODE NUMBER
				A008

修订 REV	标记 MARK	修改摘要 REVISION DESCRIPTION	签名 SIGNATURE	日期 DATE
AO		NEW RELEASE	WANG	2015-07-12

**Ordering Information:**

HDGC3030WV-S-F-XP - \*\*\* - \*\*\* - \*\*\*  
1 2 3 4

- 1.Part No.
- 2.Size(H):  
(blank);2.00mm  
H30;3.00mm
- 3.Material:  
(blank);LCP UL94V-0  
GWT;LCP UL94V-0,GWT 750°C
- 4.Finish:  
(blank);Tin over Nickel  
G;Gold over Nickel(1"U)  
G3;Gold over Nickel(3"U)  
G15;Gold over Nickel(15"U)  
G30;Gold over Nickel(30"U)

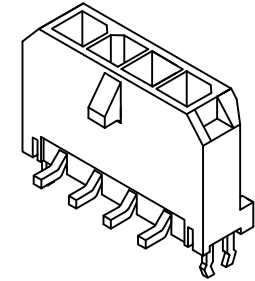

**SPECIFICATIONS:**

Current Rating: 5A AC,DC  
Voltage Rating: 250V AC,DC  
Temperature Range: -25°C ~ +85°C  
Contact Resistance: 10mΩ Max  
Insulation Resistance: 1000MΩ Min  
Withstanding Voltage: 1500V AC/minute  
Pin Material: Brass/Tin over Nickel  
Material: LCP,UL94V-0(Black)

**Ordering Information & Dimensions**

Circuits	Dimensions(mm)			Circuits	Dimensions(mm)		
	A	B	C		A	B	C
2P	3.00	9.65	7.30	8P	21.00	27.65	25.30
3P	6.00	12.65	10.30	9P	24.00	30.65	28.30
4P	9.00	15.65	13.30	10P	27.00	33.65	31.30
5P	12.00	18.65	16.30	11P	30.00	36.65	34.30
6P	15.00	21.65	19.30	12P	33.00	39.65	37.30
7P	18.00	24.65	22.30				

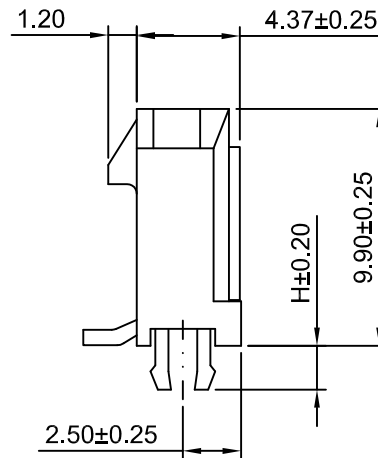
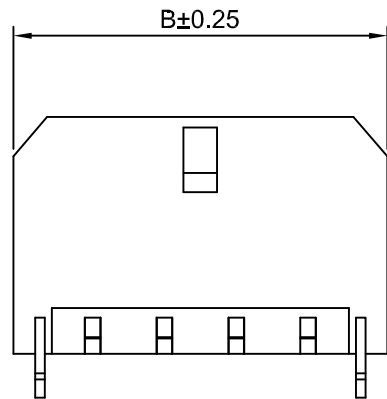
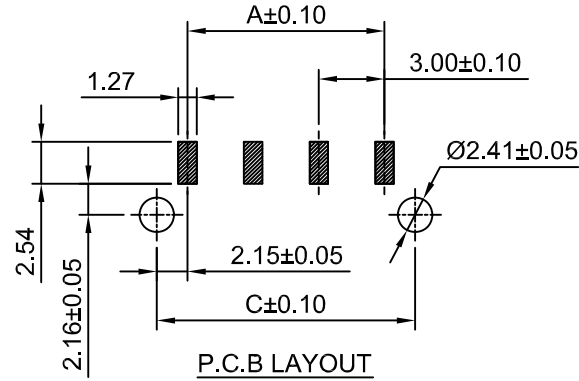
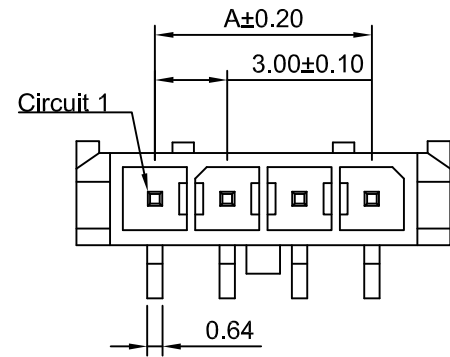

深圳市华德共创科技有限公司

SHENZHEN HUADE CO-CREATE TECHNOLOGY CO.,LTD

TEL : 0755-27129737 FAX : 0755-29940187

-TOLERANCES- UNLESS OTHERWISE SPECIFIED 公差参数表				TITLE: 产品名称 : 3.00mm Pitch 180° Wafer	
X.X	±0.30	X.X°	±3°	APPD: 核准 :	XIE
X.XX	±0.30	X.XX°	±2°	CHECK: 校对 :	WANG
X.XXX	±0.10	X.XXX°	±1°	DRAW: 绘图 :	WANG
PART NO: 产品编号 :		HDGC3030WV-S-F-XP			
DATE	SCALE	UNIT	CODE NUMBER		
2015-07-12	3:1	mm	A008		

修订 REV	标记 MARK	修改摘要 REVISION DESCRIPTION	签名 SIGNATURE	日期 DATE
AO		NEW RELEASE	WANG	2015-07-12

**Ordering Information:**

HDGC3030WR-S-F-XP - \*\*\* - \*\*\* - \*\*\*  
1 2 3 4

- Part No.
- Size(H):  
(blank):2.00mm  
H30:3.10mm
- Material:  
(blank):LCP UL94V-0  
GWT:LCP UL94V-0,GWT 750°C
- Finish:  
(blank):Tin over Nickel  
G:Gold over Nickel(1"U)  
G3:Gold over Nickel(3"U)  
G15:Gold over Nickel(15"U)  
G30:Gold over Nickel(30"U)

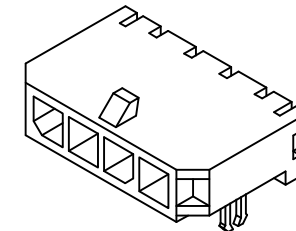

**SPECIFICATIONS:**

Current Rating: 5A AC,DC  
Voltage Rating: 250V AC,DC  
Temperature Range: -25°C ~ +85°C  
Contact Resistance: 10mΩ Max  
Insulation Resistance: 1000MΩ Min  
Withstanding Voltage: 1500V AC/minute  
Pin Material: Brass/Tin over Nickel  
Material: LCP,UL94V-0(Black)

**Ordering Information & Dimensions**

Circuits	Dimensions(mm)			Circuits	Dimensions(mm)		
	A	B	C		A	B	C
2P	3.00	9.65	7.30	8P	21.00	27.65	25.30
3P	6.00	12.65	10.30	9P	24.00	30.65	28.30
4P	9.00	15.65	13.30	10P	27.00	33.65	31.30
5P	12.00	18.65	16.30	11P	30.00	36.65	34.30
6P	15.00	21.65	19.30	12P	33.00	39.65	37.30
7P	18.00	24.65	22.30				

**HDGC** 深圳市华德共创科技有限公司  
SHENZHEN HUADE CO-CREATE TECHNOLOGY CO.,LTD  
TEL : 0755-27129737 FAX : 0755-29940187

-TOLERANCES- UNLESS OTHERWISE SPECIFIED 公差参数表			 		TITLE: 3.00mm Pitch 产品名称: 90° Wafer			
X.X	±0.30	X.X°	±3°	APPD: 核准:	XIE			
X.XX	±0.30	X.XX°	±2°	CHECK: 校对:	WANG			
X.XXX	±0.10	X.XXX°	±1°	DRAW: 绘图:	WANG			
PART NO: 产品编号:					HDGC3030WR-S-F-XP			
DATE					SCALE	UNIT	CODE NUMBER	
2015-07-12					3:1	mm	A008	

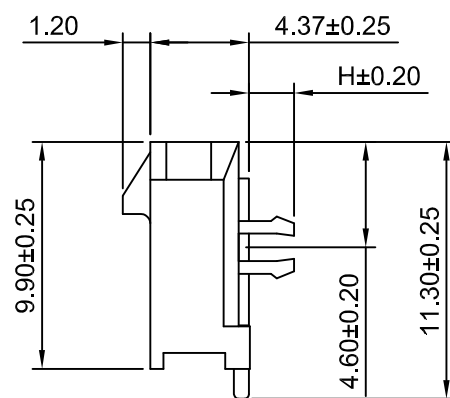
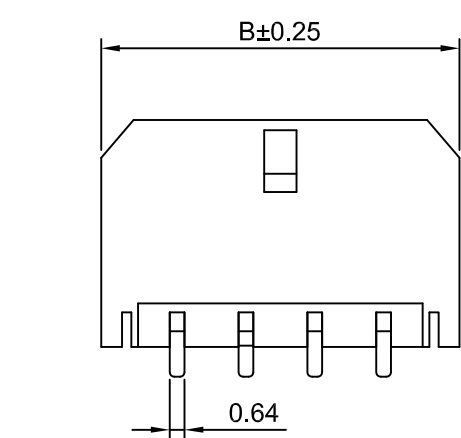
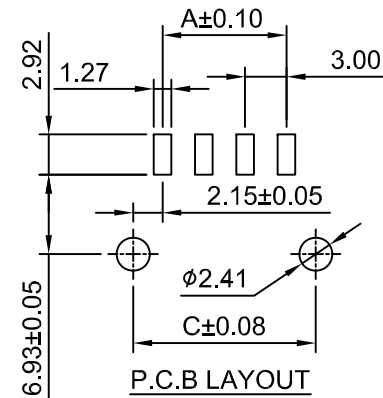
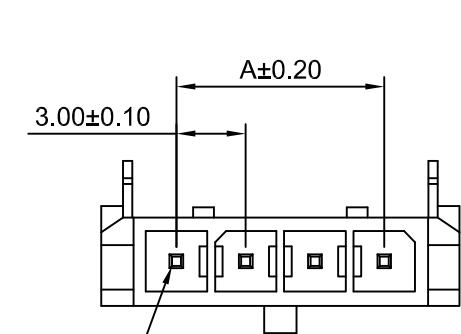

修订 REV	标记 MARK	修改摘要 REVISION DESCRIPTION	签名 SIGNATURE	日期 DATE
AO		NEW RELEASE	WANG	2015-07-12

Ordering Information:

HDGC3030WV-2xXP -  $\frac{-}{1}$  -  $\frac{*}{2}$  -  $\frac{*}{3}$  -  $\frac{*}{4}$

- Part No.
- Style:  
(blank):Type 1  
2:Type 2  
3:Type 3
- Material:  
(blank):Nylon 66 UL94V-0  
LCP:LCP UL94V-0  
GWT:LCP UL94V-0,GWT 750°C
- Finish:  
(blank):Tin over Nickel  
G:Gold over Nickel(1"U)  
G3:Gold over Nickel(3"U)  
G15:Gold over Nickel(15"U)  
G30:Gold over Nickel(30"U)

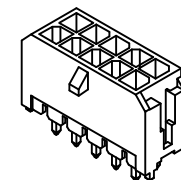

SPECIFICATIONS:

Current Rating: 5A AC,DC  
Voltage Rating: 250V AC,DC  
Temperature Range: -25°C ~ +85°C  
Contact Resistance: 10mΩ Max  
Insulation Resistance: 1000MΩ Min  
Withstanding Voltage: 1500V AC/minute  
Pin Material: Brass/Tin over Nickel  
Material: Nylon 66,UL94V-0(Black)

Ordering Information & Dimensions

Circuits	Dimensions(mm)		Circuits	Dimensions(mm)	
	A	B		A	B
2x1P	—	6.65	2x7P	18.00	24.65
2x2P	3.00	9.65	2x8P	21.00	27.65
2x3P	6.00	12.65	2x9P	24.00	30.65
2x4P	9.00	15.65	2x10P	27.00	33.65
2x5P	12.00	18.65	2x11P	30.00	36.65
2x6P	15.00	21.65	2x12P	33.00	39.65

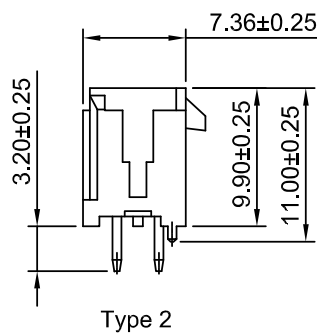
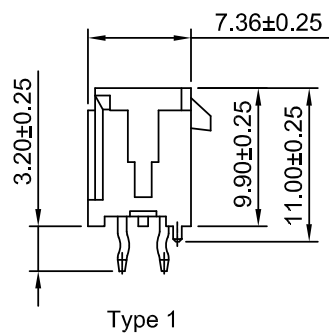
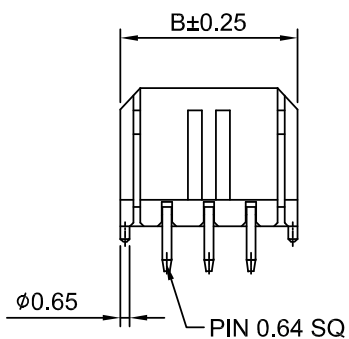
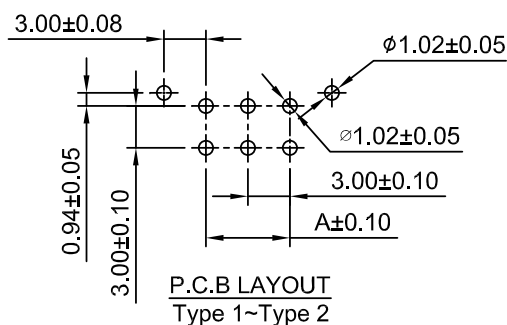
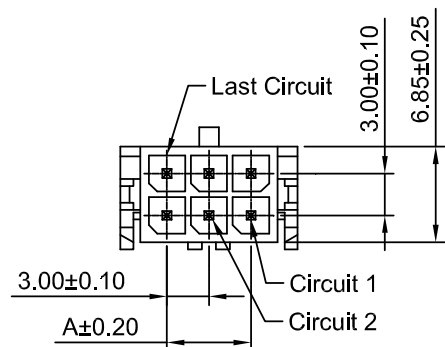
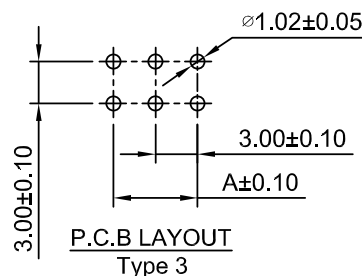
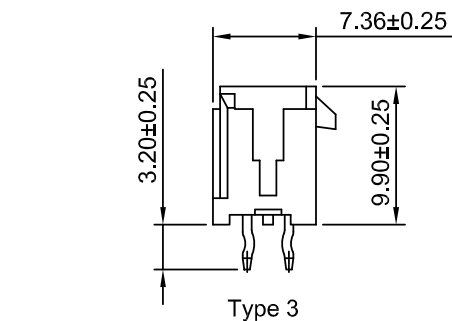

深圳市华德共创科技有限公司

SHENZHEN HUADE CO-CREATE TECHNOLOGY CO.,LTD

TEL : 0755-27129737 FAX : 0755-29940187

-TOLERANCES- UNLESS OTHERWISE SPECIFIED 公差参数表				TITLE: 产品名称: 3.00mm Pitch 180° Wafer	
X.X	±0.30	X.X°	±3°	APPD: 核准:	XIE
X.XX	±0.30	X.XX°	±2°	CHECK: 校对:	WANG
X.XXX	±0.10	X.XXX°	±1°	DRAW: 绘图:	WANG
PART NO: 产品编号:				HDGC3030WV-2xXP	
DATE		SCALE	UNIT	CODE NUMBER	
2015-07-12		3:1	mm	A008	

修订 REV	标记 MARK	修改摘要 REVISION DESCRIPTION	签名 SIGNATURE	日期 DATE
AO		NEW RELEASE	WANG	2015-07-12

Ordering Information:  
 HDGC3030WR-2xXP - \*\* - \*\*  
 1 2 3

- Part No.
- Material:  
 (blank):Nylon 66 UL94V-0  
 LCP:LCP UL94V-0  
 GWT:Nylon 66 UL94V-0,GWT 750°C
- Finish:  
 (blank):Tin over Nickel  
 G:Gold over Nickel(1"U)  
 G3:Gold over Nickel(3"U)  
 G15:Gold over Nickel(15"U)  
 G30:Gold over Nickel(30"U)

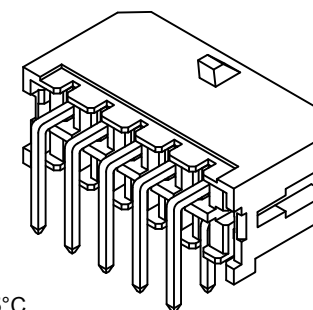

**SPECIFICATIONS:**

Current Rating: 5A AC,DC  
 Voltage Rating: 250V AC,DC  
 Temperature Range: -25°C ~ +85°C  
 Contact Resistance: 10mΩ Max  
 Insulation Resistance: 1000MΩ Min  
 Withstanding Voltage: 1500V AC/minute  
 Pin Material: Brass/Tin over Nickel  
 Material: Nylon 66,UL94V-0(Black)

Ordering Information & Dimensions

Circuits	Dimensions(mm)		Circuits	Dimensions(mm)	
	A	B		A	B
2x1P	---	6.65	2x7P	18.00	24.65
2x2P	3.00	9.65	2x8P	21.00	27.65
2x3P	6.00	12.65	2x9P	24.00	30.65
2x4P	9.00	15.65	2x10P	27.00	33.65
2x5P	12.00	18.65	2x11P	30.00	36.65
2x6P	15.00	21.65	2x12P	33.00	39.65

**P.C.B LAYOUT**

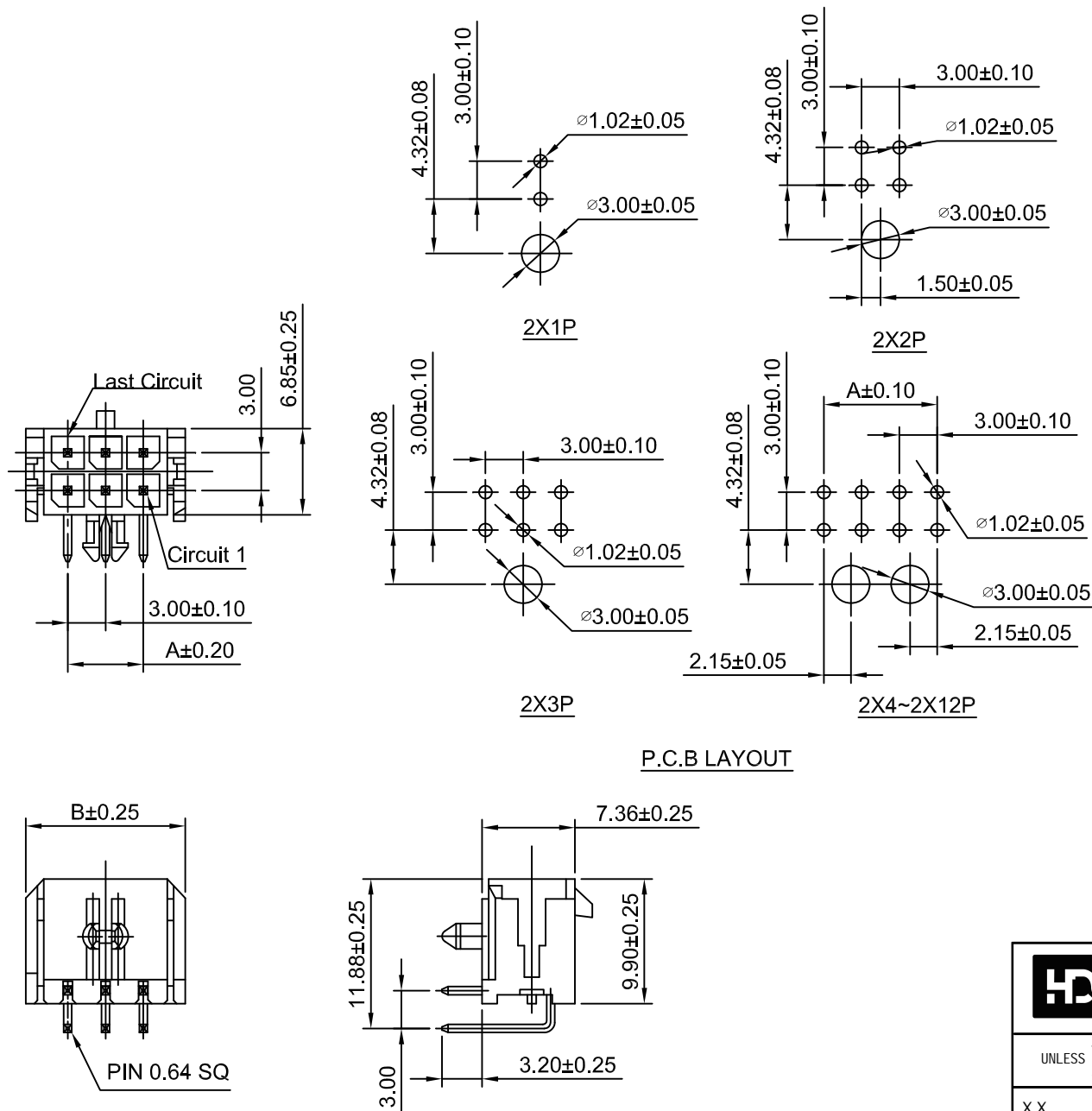

**深圳市华德共创科技有限公司**  
 SHENZHEN HUADE CO-CREATE TECHNOLOGY CO.,LTD  
 TEL : 0755-27129737 FAX : 0755-29940187

-TOLERANCES- UNLESS OTHERWISE SPECIFIED 公差参数表				TITLE: 3.00mm Pitch 产品名称: 90° Wafer							
X.X	±0.30	X.X°	±3°	APPD: 核准:	XIE			PART NO: 产品编号:	HDGC3030WR-2xXP		
X.XX	±0.30	X.XX°	±2°	CHECK: 校对:	WANG			DATE	SCALE	UNIT	CODE NUMBER
X.XXX	±0.10	X.XXX°	±1°	DRAW: 绘图:	WANG			2015-07-12	3:1	mm	A008

修订 REV	标记 MARK	修改摘要 REVISION DESCRIPTION	签名 SIGNATURE	日期 DATE
AO		NEW RELEASE	WANG	2015-07-12

**Ordering Information:**

HDGC3030WV-S-2xXP - \*\* - \*\*  
1 2 3

- Part No.
- Material:  
(blank):LCP UL94V-0  
GWT:LCP UL94V-0,GWT 750°C
- Finish:  
(blank):Tin over Nickel  
G:Gold over Nickel(1"U)  
G3:Gold over Nickel(3"U)  
G15:Gold over Nickel(15"U)  
G30:Gold over Nickel(30"U)

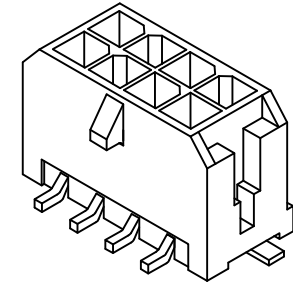

**SPECIFICATIONS:**

Current Rating: 5A AC,DC  
Voltage Rating: 250V AC,DC  
Temperature Range: -25°C ~ +85°C  
Contact Resistance: 10mΩ Max  
Insulation Resistance: 1000MΩ Min  
Withstanding Voltage: 1500V AC/minute  
Pin Material: Brass/Tin over Nickel  
Material: LCP,UL94-V0(Black)

**Ordering Information & Dimensions**

Circuits	Dimensions(mm)			Circuits	Dimensions(mm)		
	A	B	C		A	B	C
2x1P	---	6.65	11.20	2x7P	18.00	24.65	29.20
2x2P	3.00	9.65	14.20	2x8P	21.00	27.65	32.20
2x3P	6.00	12.65	17.20	2x9P	24.00	30.65	35.20
2x4P	9.00	15.65	20.20	2x10P	27.00	33.65	38.20
2x5P	12.00	18.65	23.20	2x11P	30.00	36.65	41.20
2x6P	15.00	21.65	26.20	2x12P	33.00	39.65	44.20

**HDGC** 深圳市华德共创科技有限公司  
SHENZHEN HUADE CO-CREATE TECHNOLOGY CO.,LTD  
TEL : 0755-27129737 FAX : 0755-29940187

-TOLERANCES- UNLESS OTHERWISE SPECIFIED 公差参数表					TITLE: 3.00mm Pitch 产品名称: 180° Wafer			
X.X	±0.30	X.X°	±3°	APPD: 核准:	XIE			
X.XX	±0.30	X.XX°	±2°	CHECK: 校对:	DATE	SCALE	UNIT	CODE NUMBER
X.XXX	±0.10	X.XXX°	±1°	DRAW: 绘图:	2015-07-12	3:1	mm	A008

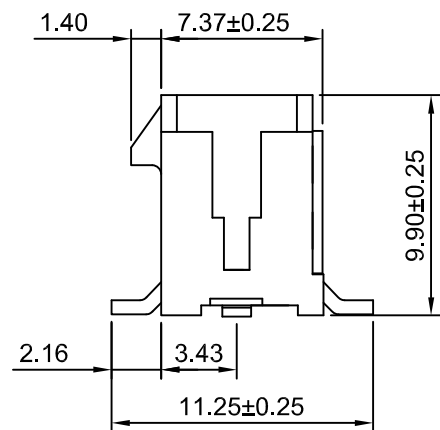
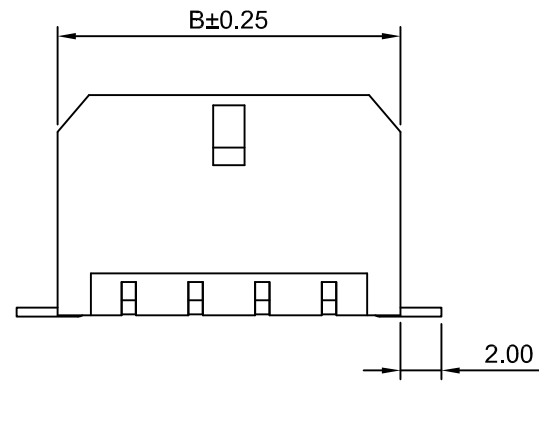
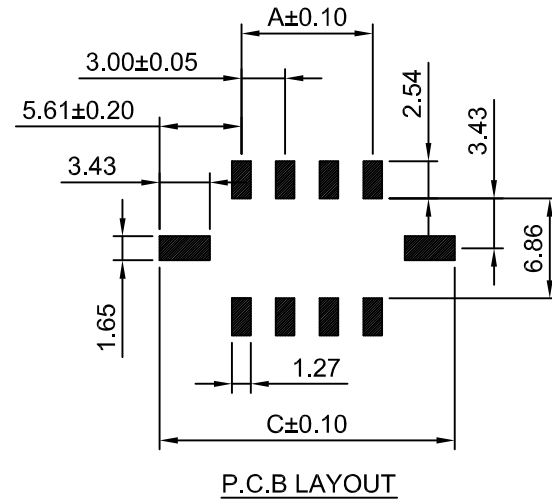
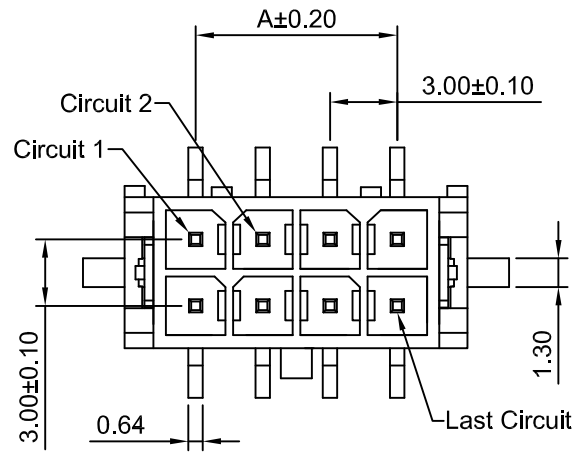

修订 REV	标记 MARK	修改摘要 REVISION DESCRIPTION	签名 SIGNATURE	日期 DATE
AO		NEW RELEASE	WANG	2015-07-12

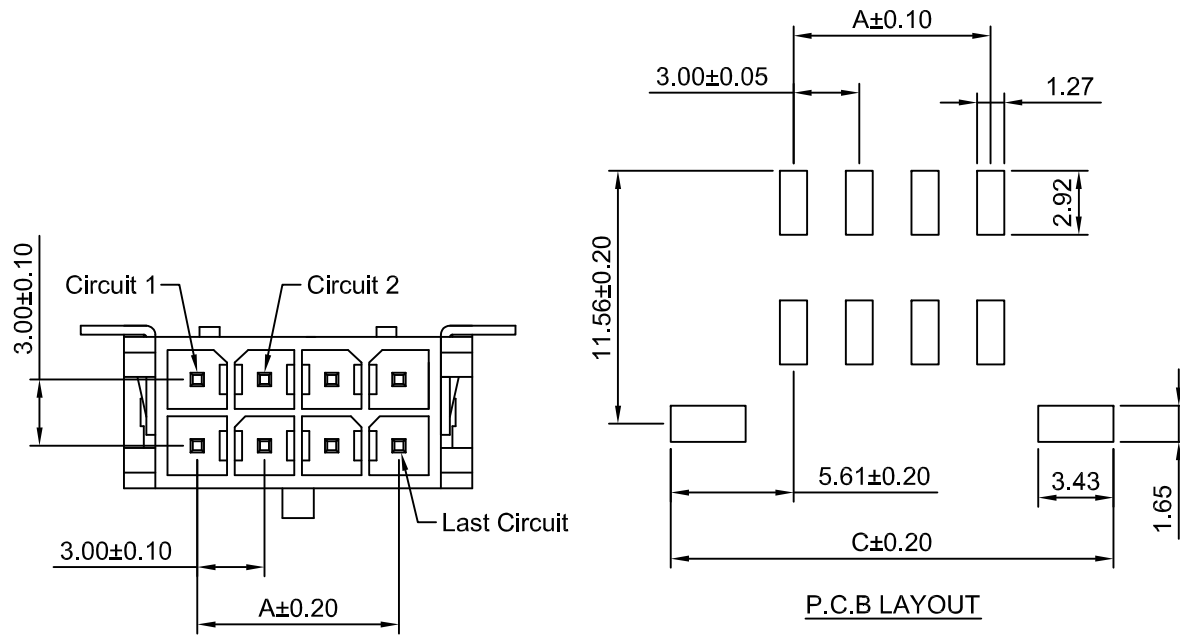

P.C.B LAYOUT

Ordering Information:

HDGC3030WR-S-2xXP - \*\* - \*\*  
1 2 3

- Part No.
- Material:  
(blank):LCP UL94V-0  
GWT:LCP UL94V-0,GWT 750°C
- Finish:  
(blank):Tin over Nickel  
G:Gold over Nickel(1"U)  
G3:Gold over Nickel(3"U)  
G15:Gold over Nickel(15"U)  
G30:Gold over Nickel(30"U)

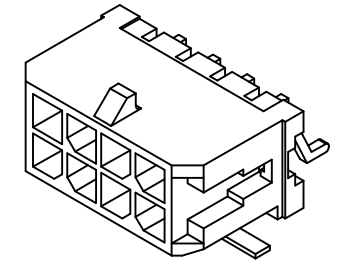

SPECIFICATIONS:

Current Rating: 5A AC,DC  
Voltage Rating: 250V AC,DC  
Temperature Range: -25°C ~ +85°C  
Contact Resistance: 10mΩ Max  
Insulation Resistance: 1000MΩ Min  
Withstanding Voltage: 1500V AC/minute  
Pin Material: Brass/Tin over Nickel  
Material: LCP,UL94V-0(Black)

Ordering Information & Dimensions

Circuits	Dimensions(mm)			Circuits	Dimensions(mm)		
	A	B	C		A	B	C
2x1P	---	6.65	11.20	2x7P	18.00	24.65	29.20
2x2P	3.00	9.65	14.20	2x8P	21.00	27.65	32.20
2x3P	6.00	12.65	17.20	2x9P	24.00	30.65	35.20
2x4P	9.00	15.65	20.20	2x10P	27.00	33.65	38.20
2x5P	12.00	18.65	23.20	2x11P	30.00	36.65	41.20
2x6P	15.00	21.65	26.20	2x12P	33.00	39.65	44.20

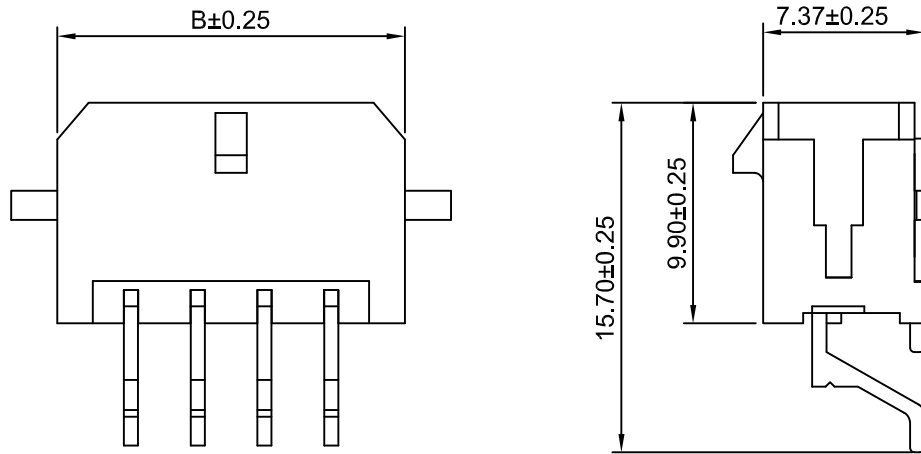

**深圳市华德共创科技有限公司**

SHENZHEN HUADE CO-CREATE TECHNOLOGY CO.,LTD

TEL : 0755-27129737 FAX : 0755-29940187

-TOLERANCES- UNLESS OTHERWISE SPECIFIED 公差参数表					TITLE: 3.00mm Pitch				
					产品名称: 90° Wafer				
X.X	±0.30	X.X°	±3°	APPD: 核准:	PART NO: 产品编号: HDGC3030WR-S-2xXP				
X.XX	±0.30	X.XX°	±2°	CHECK: 校对:	WANG	DATE	SCALE	UNIT	CODE NUMBER
X.XXX	±0.10	X.XXX°	±1°	DRAW: 绘图:	WANG	2015-07-12	3:1	mm	A008

修订 REV	标记 MARK	修改摘要 REVISION DESCRIPTION	签名 SIGNATURE	日期 DATE
AO		NEW RELEASE	WANG	2015-07-12

Ordering Information:

HDGC3030WV-F-2xXP - \*\*\* - \*\*\* - \*\*\*  
1 2 3 4

- Part No.
- Size(H):  
(blank):2.00mm  
H30:3.00mm
- Material:  
(blank):Nylon 66 UL94V-0  
LCP:LCP UL94V-0  
GWT:LCP UL94V-0,GWT 750°C
- Finish:  
(blank):Tin over Nickel  
G:Gold over Nickel(1"U)  
G3:Gold over Nickel(3"U)  
G15:Gold over Nickel(15"U)  
G30:Gold over Nickel(30"U)

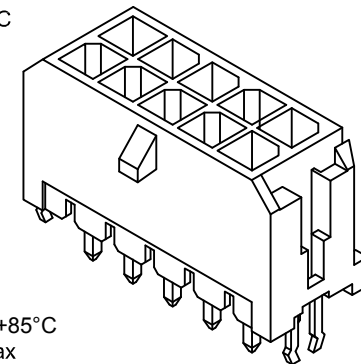

SPECIFICATIONS:

Current Rating: 5A AC,DC  
Voltage Rating: 250V AC,DC  
Temperature Range: -25°C ~ +85°C  
Contact Resistance: 10mΩ Max  
Insulation Resistance: 1000MΩ Min  
Withstanding Voltage: 1500V AC/minute  
Pin Material: Brass/Tin over Nickel  
Material: Nylon 66,UL94V-0(Black)

Ordering Information & Dimensions

Circuits	Dimensions(mm)			Circuits	Dimensions(mm)		
	A	B	C		A	B	C
2x1P	—	6.65	4.30	2x7P	18.00	24.65	22.30
2x2P	3.00	9.65	7.30	2x8P	21.00	27.65	25.30
2x3P	6.00	12.65	10.30	2x9P	24.00	30.65	28.30
2x4P	9.00	15.65	13.30	2x10P	27.00	33.65	31.30
2x5P	12.00	18.65	16.30	2x11P	30.00	36.65	34.30
2x6P	15.00	21.65	19.30	2x12P	33.00	39.65	37.30

**HDGC** 深圳市华德共创科技有限公司  
SHENZHEN HUADE CO-CREATE TECHNOLOGY CO.,LTD  
TEL : 0755-27129737 FAX : 0755-29940187

-TOLERANCES- UNLESS OTHERWISE SPECIFIED 公差参数表				 		TITLE: 3.00mm Pitch 产品名称: 180° Wafer			
X.X	±0.30	X.X°	±3°	APPD: 核准:	XIE	PART NO: 产品编号: HDGC3030WV-F-2xXP			
X.XX	±0.30	X.XX°	±2°	CHECK: 校对:	WANG	DATE	SCALE	UNIT	CODE NUMBER
X.XXX	±0.10	X.XXX°	±1°	DRAW: 绘图:	WANG	2015-07-12	4:1	mm	A008

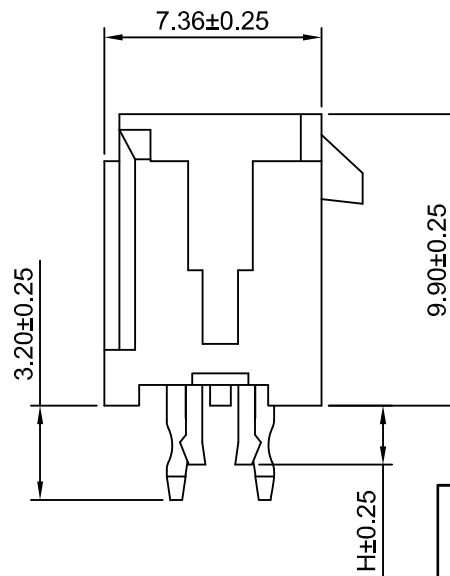
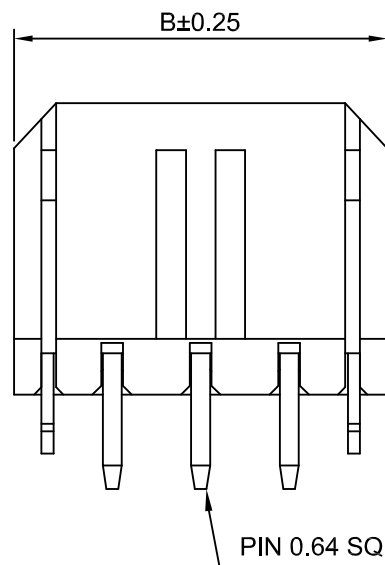
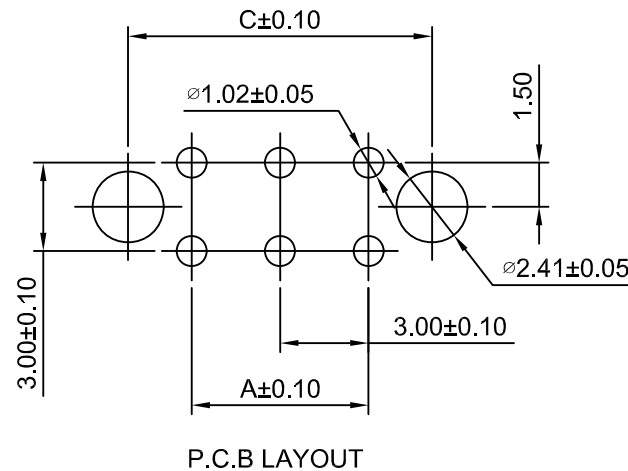
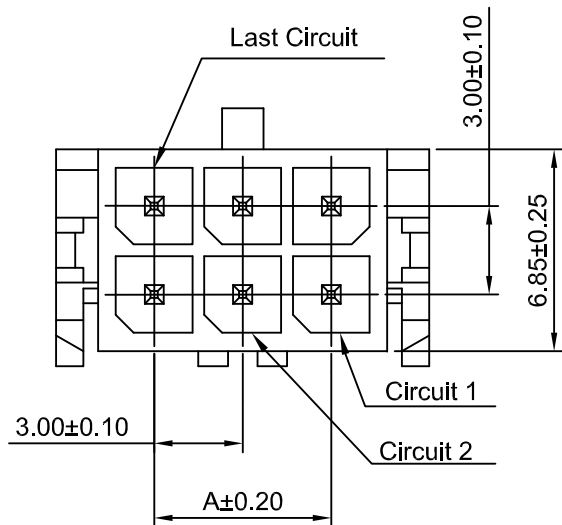

修订 REV	标记 MARK	修改摘要 REVISION DESCRIPTION	签名 SIGNATURE	日期 DATE
AO		NEW RELEASE	WANG	2015-07-12

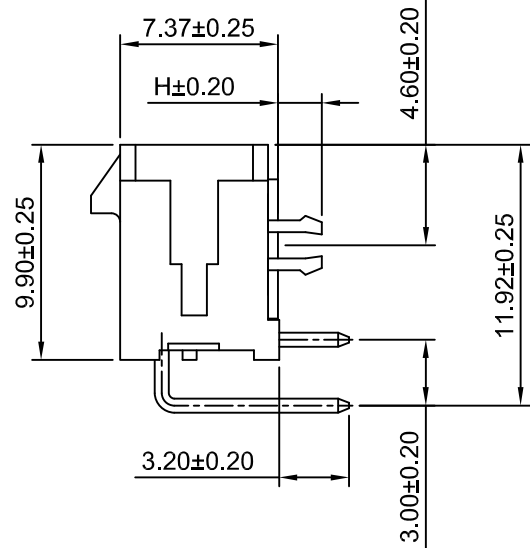
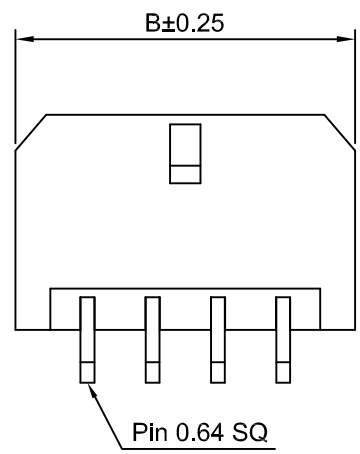
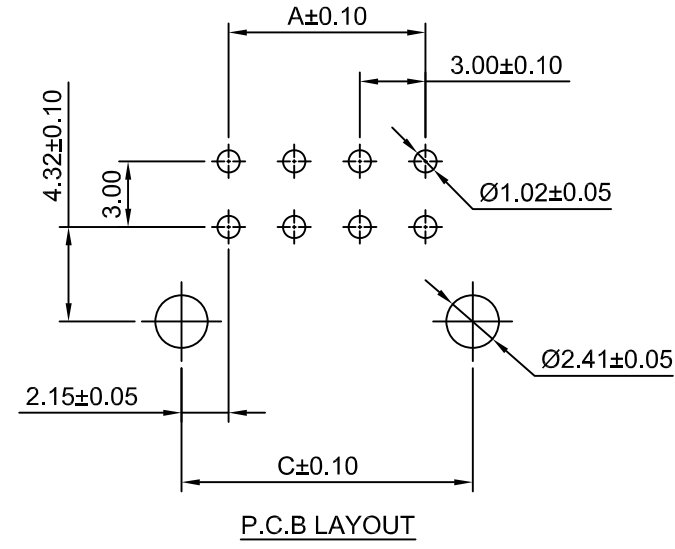
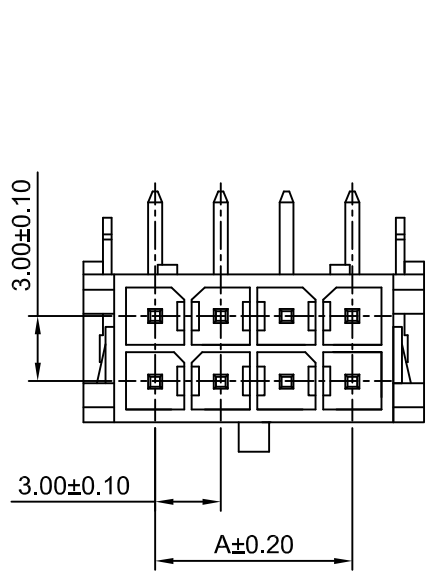

**Ordering Information:**

HDGC3030WR-F-2xXP - \*\*\* - \*\*\* - \*\*\*  
1 2 3 4

- Part No.
- Size(H):  
(blank):2.00mm  
H30:3.00mm
- Material:  
(blank):Nylon 66 UL94V-0  
LCP:LCP UL94V-0  
GWT:Nylon 66 UL94V-0,GWT 750°C
- Finish:  
(blank):Tin over Nickel  
G:Gold over Nickel(1"U)  
G3:Gold over Nickel(3"U)  
G15:Gold over Nickel(15"U)  
G30:Gold over Nickel(30"U)

**SPECIFICATIONS:**

Current Rating: 5A AC,DC  
Voltage Rating: 250V AC,DC  
Temperature Range: -25°C ~ +85°C  
Contact Resistance: 10mΩ Max  
Insulation Resistance: 1000MΩ Min  
Withstanding Voltage: 1500V AC/minute  
Pin Material: Brass/Tin-plated  
Material: Nylon 66,UL94V-0(Black)

**Ordering Information & Dimensions**

Circuits	Dimensions(mm)			Circuits	Dimensions(mm)		
	A	B	C		A	B	C
2x1P	---	6.65	4.30	2x7P	18.00	24.65	22.30
2x2P	3.00	9.65	7.30	2x8P	21.00	27.65	25.30
2x3P	6.00	12.65	10.30	2x9P	24.00	30.65	28.30
2x4P	9.00	15.65	13.30	2x10P	27.00	33.65	31.30
2x5P	12.00	18.65	16.30	2x11P	30.00	36.65	34.30
2x6P	15.00	21.65	19.30	2x12P	33.00	39.65	37.30

**深圳市华德共创科技有限公司**

SHENZHEN HUADE CO-CREATE TECHNOLOGY CO.,LTD

TEL : 0755-27129737 FAX : 0755-29940187

-TOLERANCES- UNLESS OTHERWISE SPECIFIED 公差参数表					TITLE: 3.00mm Pitch 产品名称: 90° Wafer			
X.X	±0.30	X.X°	±3°	APPD: 核准:	XIE			
X.XX	±0.30	X.XX°	±2°	CHECK: 校对:	WANG			
X.XXX	±0.10	X.XXX°	±1°	DRAW: 绘图:	WANG			
PART NO: 产品编号:					HDGC3030WR-F-2xXP			
		DATE	SCALE	UNIT	CODE NUMBER			
		2015-07-12	3:1	mm	A008			

修订 REV	标记 MARK	修改摘要 REVISION DESCRIPTION	签名 SIGNATURE	日期 DATE
AO		NEW RELEASE	WANG	2015-07-12

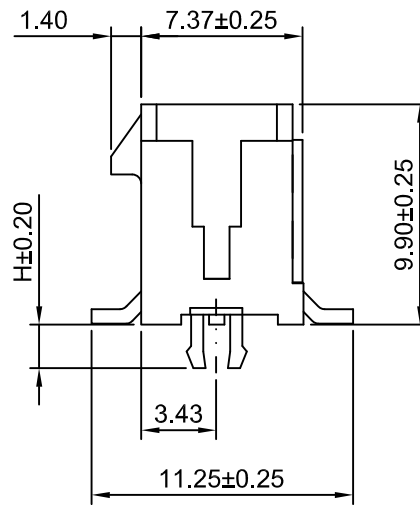
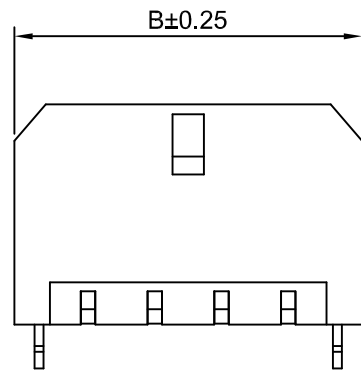
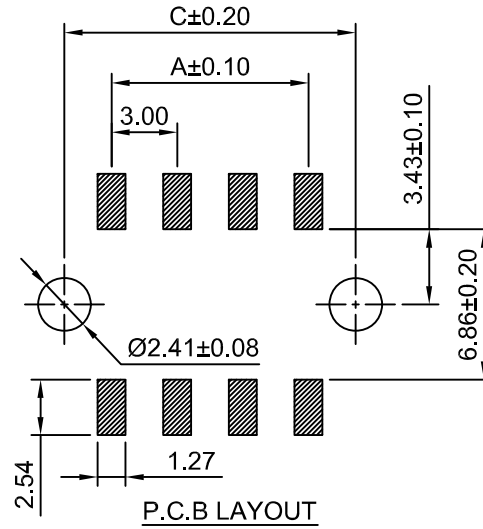
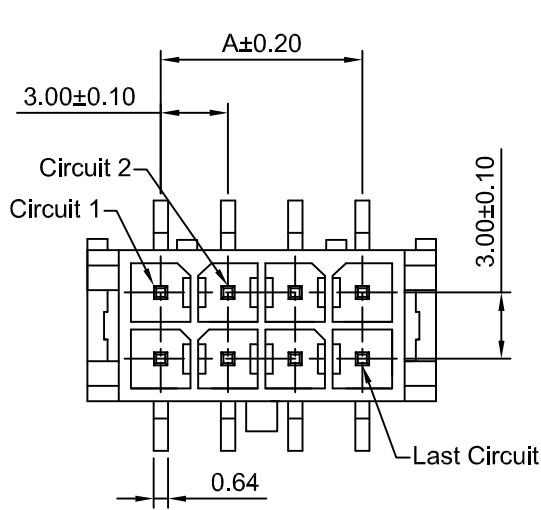

**Ordering Information:**

HDGC3030WV-S-F-2xXP - \*\*\* - \*\*\* - \*\*\*  
1 2 3 4

- Part No.
- Size(H):  
(blank):2.00mm  
H30:3.00mm
- Material:  
(blank):LCP UL94V-0  
GWT:LCP UL94V-0,GWT 750°C
- Finish:  
(blank):Tin over Nickel  
G:Gold over Nickel(1"U)  
G3:Gold over Nickel(3"U)  
G15:Gold over Nickel(15"U)  
G30:Gold over Nickel(30"U)

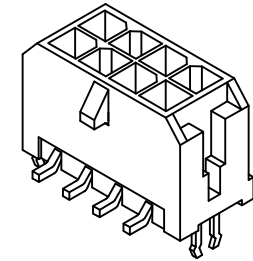

**SPECIFICATIONS:**

Current Rating: 5A AC,DC  
Voltage Rating: 250V AC,DC  
Temperature Range: -25°C ~ +85°C  
Contact Resistance: 10mΩ Max  
Insulation Resistance: 1000MΩ Min  
Withstanding Voltage: 1500V AC/minute  
Pin Material: Brass/Tin over Nickel  
Material: LCP,UL94V-0(Black)

**Ordering Information & Dimensions**

Circuits	Dimensions(mm)			Circuits	Dimensions(mm)		
	A	B	C		A	B	C
2x1P	-----	6.65	4.30	2x7P	18.00	24.65	22.30
2x2P	3.00	9.65	7.30	2x8P	21.00	27.65	25.30
2x3P	6.00	12.65	10.30	2x9P	24.00	30.65	28.30
2x4P	9.00	15.65	13.30	2x10P	27.00	33.65	31.30
2x5P	12.00	18.65	16.30	2x11P	30.00	36.65	34.30
2x6P	15.00	21.65	19.30	2x12P	33.00	39.65	37.30



**深圳市华德共创科技有限公司**

SHENZHEN HUADE CO-CREATE TECHNOLOGY CO.,LTD

TEL : 0755-27129737 FAX : 0755-29940187

-TOLERANCES- UNLESS OTHERWISE SPECIFIED 公差参数表					TITLE: 3.00mm Pitch 产品名称: 180° Wafer			
X.X	±0.30	X.X°	±3°	APPD: 核准:	XIE			
X.XX	±0.30	X.XX°	±2°	CHECK: 校对:	WANG			
X.XXX	±0.10	X.XXX°	±1°	DRAW: 绘图:	WANG			
PART NO: 产品编号:					HDGC3030WV-S-F-2xXP			
DATE		SCALE	UNIT	CODE NUMBER				
2015-07-12		3:1	mm	A008				

修订 REV	标记 MARK	修改摘要 REVISION DESCRIPTION	签名 SIGNATURE	日期 DATE
AO		NEW RELEASE	WANG	2015-07-12

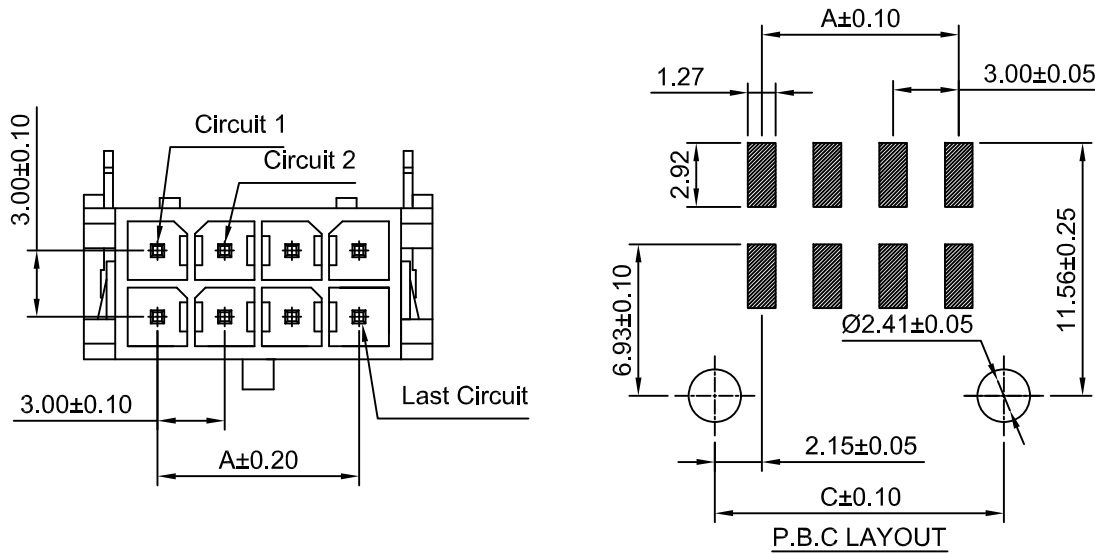

**Ordering Information:**

HDGC3030WR-S-F-2xXP - \*\*\* - \*\*\* - \*\*\*  
1 2 3 4

- Part No.
- Size(H):  
(blank):2.00mm  
H30:3.00mm
- Material:  
(blank):LCP UL94V-0  
GWT:LCP UL94V-0,GWT 750°C
- Finish:  
(blank):Tin over Nickel  
G:Gold over Nickel(1"U)  
G3:Gold over Nickel(3"U)  
G15:Gold over Nickel(15"U)  
G30:Gold over Nickel(30"U)

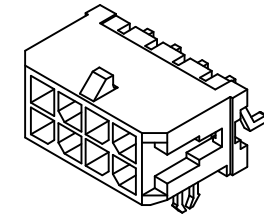

**SPECIFICATIONS:**

Current Rating: 5A AC,DC  
Voltage Rating: 250V AC,DC  
Temperature Range: -25°C ~ +85°C  
Contact Resistance: 10mΩ Max  
Insulation Resistance: 1000MΩ Min  
Withstanding Voltage: 1500V AC/minute  
Pin Material: Brass/Tin over Nickel  
Material: LCP,UL94V-0(Black)

**Ordering Information & Dimensions**

Circuits	Dimensions(mm)			Circuits	Dimensions(mm)		
	A	B	C		A	B	C
2x1P	---	6.65	4.30	2x7P	18.00	24.65	22.30
2x2P	3.00	9.65	7.30	2x8P	21.00	27.65	25.30
2x3P	6.00	12.65	10.30	2x9P	24.00	30.65	28.30
2x4P	9.00	15.65	13.30	2x10P	27.00	33.65	31.30
2x5P	12.00	18.65	16.30	2x11P	30.00	36.65	34.30
2x6P	15.00	21.65	19.30	2x12P	33.00	39.65	37.30

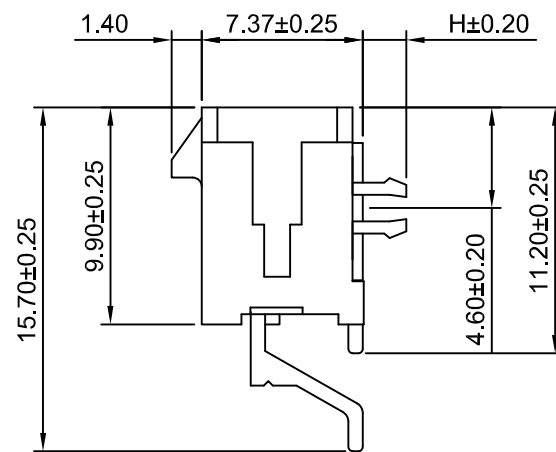
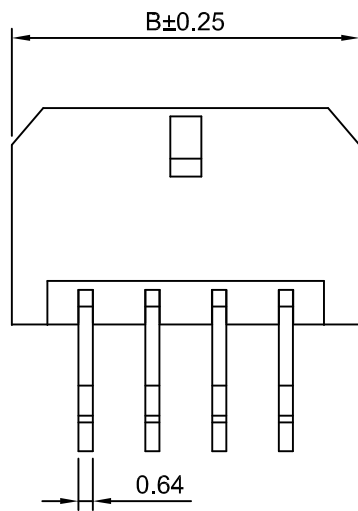

**深圳市华德共创科技有限公司**

SHENZHEN HUADE CO-CREATE TECHNOLOGY CO.,LTD

TEL : 0755-27129737 FAX : 0755-29940187

-TOLERANCES- UNLESS OTHERWISE SPECIFIED 公差参数表			TITLE: 产品名称: 3.00mm Pitch 90° Wafer	
X.X	±0.30	X.X°	±3°	APPD: 核准: XIE
X.XX	±0.30	X.XX°	±2°	CHECK: 校对: WANG
X.XXX	±0.10	X.XXX°	±1°	DRAW: 绘图: WANG
PART NO: 产品编号: HDGC3030WR-S-F-2xXP		DATE	SCALE	UNIT
		2015-07-12	3:1	mm
		CODE NUMBER		A008

修订 REV	标记 MARK	修改摘要 REVISION DESCRIPTION	签名 SIGNATURE	日期 DATE
AO		NEW RELEASE	WANG	2017-07-22

### Ordering Information:

HDGC3030WVA-2xXP - \* - \*\*  
1 2 3

- Part No.
- Style:  
(blank): Type 1  
3: Type 3
- Finish:  
(blank): Tin over Nickel  
G: Gold-flash  
G15: 15µin (0.38µm) MIN. Select Gold  
100µin (2.54µm) MIN. Select Tin  
G30: 30µin (0.76µm) MIN. Select Gold  
100µin (2.54µm) MIN. Select Tin

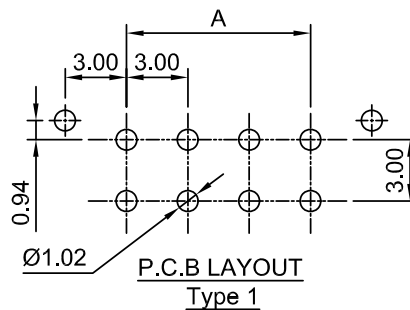
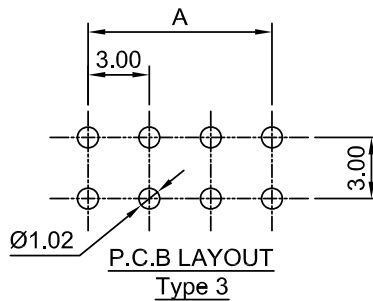
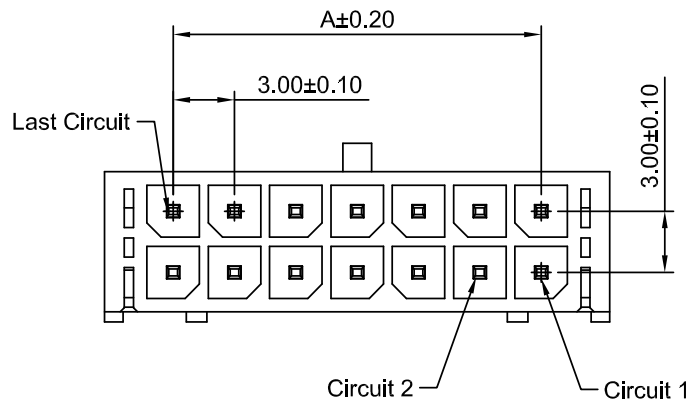
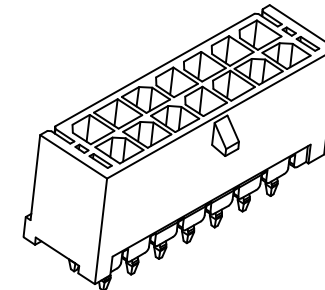

### SPECIFICATIONS:

Current Rating: 5A AC,DC  
Voltage Rating: 250V AC,DC  
Temperature Range: -25°C ~ +85°C  
Contact Resistance: 10mΩ Max  
Insulation Resistance: 1000MΩ Min  
Withstanding Voltage: 1500V AC/minute  
Pin Material: Brass/Tin over Nickel  
Material: Nylon 46, UL94V-0(Black)

### Ordering Information & Dimensions

Circuits	Dimensions(mm)		Circuits	Dimensions(mm)	
	A	B		A	B
2x1P	--	6.70	2x7P	18.00	24.70
2x2P	3.00	9.70	2x8P	21.00	27.70
2x3P	6.00	12.70	2x9P	24.00	30.70
2x4P	9.00	15.70	2x10P	27.00	33.70
2x5P	12.00	18.70	2x11P	30.00	36.70
2x6P	15.00	21.70	2x12P	33.00	39.70

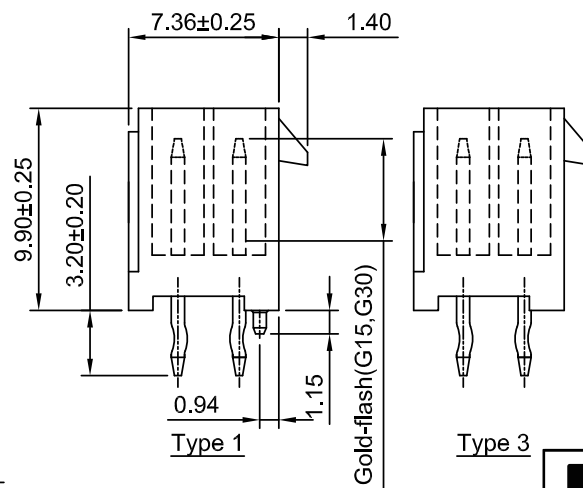
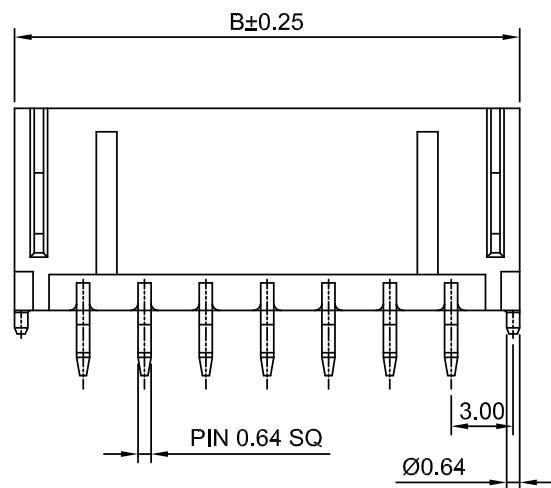

**HDGC** 深圳市华德共创科技有限公司  
SHENZHEN HUADE CO-CREATE TECHNOLOGY CO.,LTD  
TEL : 0755-27129737 FAX : 0755-29940187

-TOLERANCES- UNLESS OTHERWISE SPECIFIED 公差参数表				TITLE: 产品名称: 3.00mm Pitch 180° Wafer	
X.X	±0.30	X.X°	±3°	APPD: 核准:	XIE
X.XX	±0.30	X.XX°	±2°	CHECK: 校对:	WANG
X.XXX	±0.10	X.XXX°	±1°	DRAW: 绘图:	WANG
PART NO: 产品编号:		HDGC3030WVA-2xXP			
DATE	SCALE	UNIT	CODE NUMBER		
2017-07-22	3:1	mm	A008		

修订 REV	标记 MARK	修改摘要 REVISION DESCRIPTION	签名 SIGNATURE	日期 DATE
AO		NEW RELEASE	WANG	2017-07-22

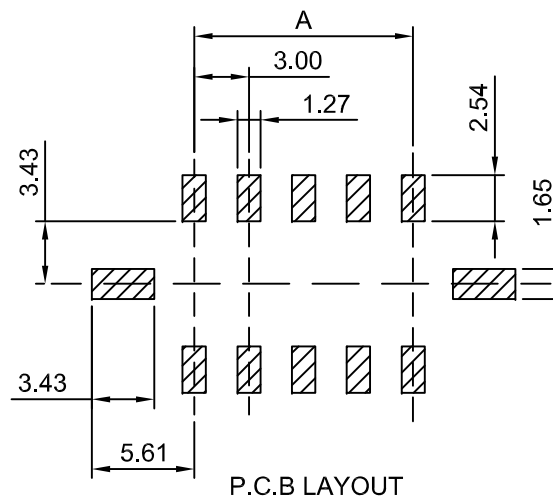
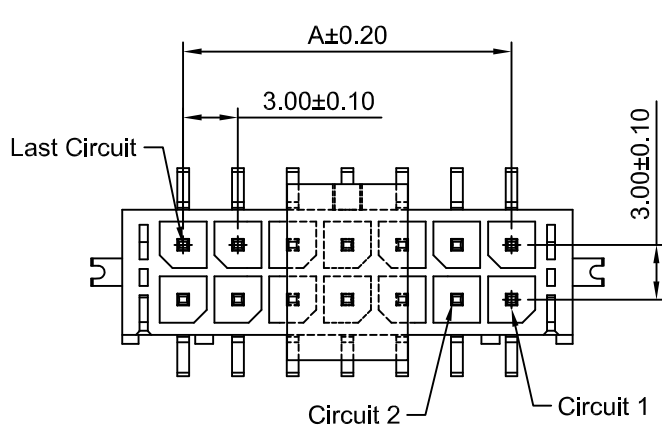

**Ordering Information:**

HDGC3030WVA-S-2xXP - \*\*  
1 2

- Part No.
- Finish:  
(blank): Tin over Nickel  
G: Gold-flash  
G15: 15μin (0.38μm) MIN. Select Gold  
100μin (2.54μm) MIN. Select Tin  
G30: 30μin (0.76μm) MIN. Select Gold  
100μin (2.54μm) MIN. Select Tin

**SPECIFICATIONS:**

Current Rating: 5A AC,DC  
Voltage Rating: 250V AC,DC  
Temperature Range: -25°C ~ +85°C  
Contact Resistance: 10mΩ Max  
Insulation Resistance: 1000MΩ Min  
Withstanding Voltage: 1500V AC/minute  
Pin Material: Brass/Tin over Nickel  
Material: Nylon 46, UL94V-0(Black)

**Ordering Information & Dimensions**

Circuits	Dimensions(mm)			Circuits	Dimensions(mm)		
	A	B	C		A	B	C
2x1P	---	6.70	6.60	2x7P	18.00	24.70	6.60
2x2P	3.00	9.70	6.60	2x8P	21.00	27.70	12.00
2x3P	6.00	12.70	6.60	2x9P	24.00	30.70	12.00
2x4P	9.00	15.70	6.60	2x10P	27.00	33.70	12.00
2x5P	12.00	18.70	6.60	2x11P	30.00	36.70	12.00
2x6P	15.00	21.70	6.60	2x12P	33.00	39.70	12.00

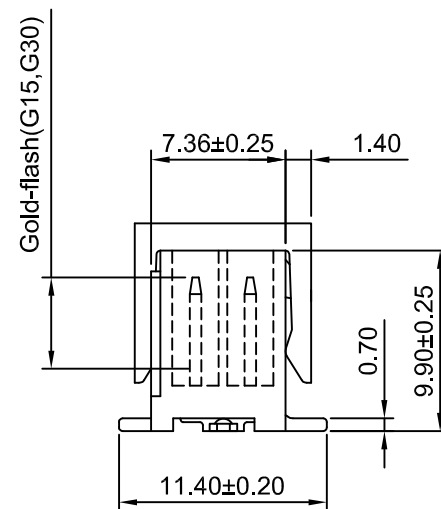
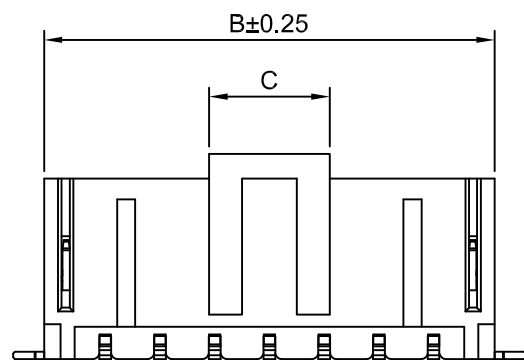

**深圳市华德共创科技有限公司**

SHENZHEN HUADE CO-CREATE TECHNOLOGY CO.,LTD

TEL : 0755-27129737 FAX : 0755-29940187

-TOLERANCES- UNLESS OTHERWISE SPECIFIED 公差参数表				TITLE: 产品名称: 3.00mm Pitch 180° Wafer	
X.X	±0.30	X.X°	±3°	APPD: 核准:	XIE
X.XX	±0.30	X.XX°	±2°	CHECK: 校对:	WANG
X.XXX	±0.10	X.XXX°	±1°	DRAW: 绘图:	WANG
PART NO: 产品编号:				HDGC3030WVA-S-2xXP	
DATE		SCALE	UNIT	CODE NUMBER	
2017-07-22		2.5:1	mm	A008	

修订 REV	标记 MARK	修改摘要 REVISION DESCRIPTION	签名 SIGNATURE	日期 DATE
AO		NEW RELEASE	WANG	2015-07-12

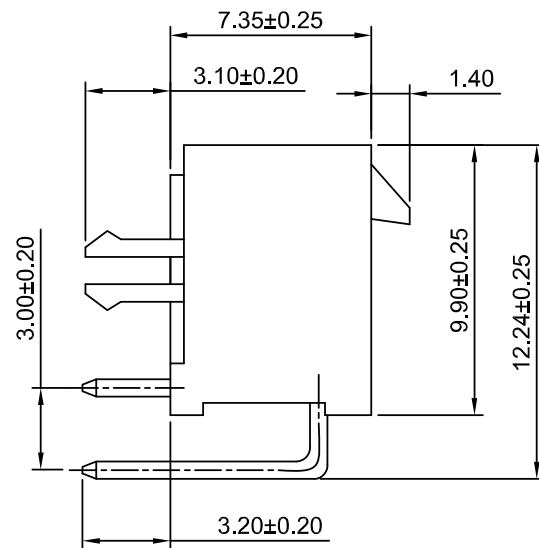
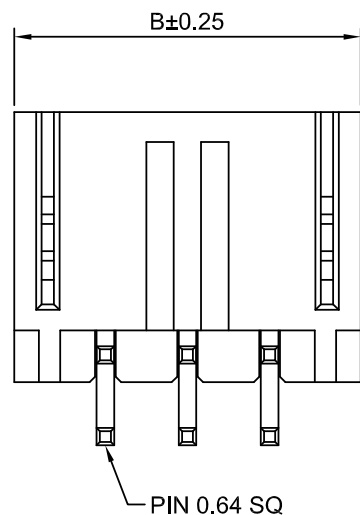
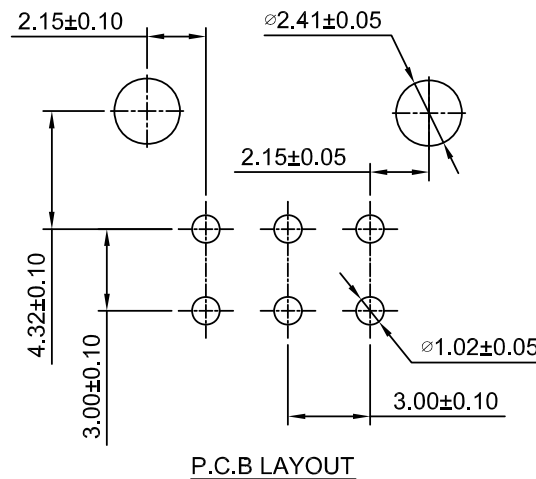
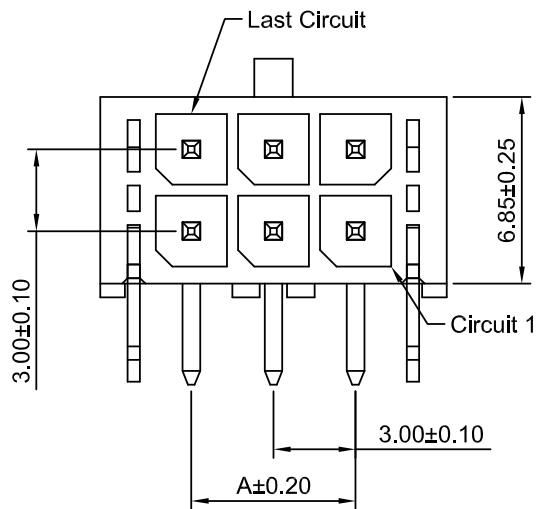

**Ordering Information:**

HDGC3030WRA-F-2xXP - \*\*\* - \*\*  
1 2 3

- Part No.
- Material:  
(blank):Nylon 6T UL94V-0  
LCP:LCP UL94V-0  
GWT:Nylon 6T UL94V-0,GWT 750°C
- Finish:  
(blank):Tin over Nickel  
G:Gold over Nickel(1"U)  
G3:Gold over Nickel(3"U)  
G15:Gold over Nickel(15"U)  
G30:Gold over Nickel(30"U)

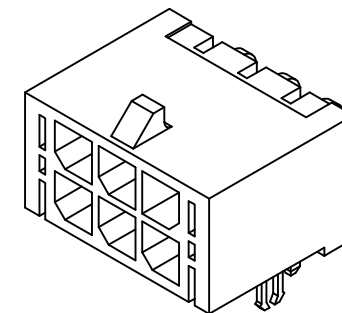

**SPECIFICATIONS:**

Current Rating: 5A AC,DC  
Voltage Rating: 250V AC,DC  
Temperature Range: -25°C ~ +85°C  
Contact Resistance: 10mΩ Max  
Insulation Resistance: 1000MΩ Min  
Withstanding Voltage: 1000V AC/minute  
Pin Material: Brass/Tin over Nickel  
Material:Nylon 6T,UL94V-0(Black)

**Ordering Information & Dimensions**

Circuits	Dimensions(mm)		Circuits	Dimensions(mm)	
	A	B		A	B
2x1P	---	6.65	2x7P	18.00	24.65
2x2P	3.00	9.65	2x8P	21.00	27.65
2x3P	6.00	12.65	2x9P	24.00	30.65
2x4P	9.00	15.65	2x10P	27.00	33.65
2x5P	12.00	18.65	2x11P	30.00	36.65
2x6P	15.00	21.65	2x12P	33.00	39.65



**深圳市华德共创科技有限公司**

SHENZHEN HUADE CO-CREATE TECHNOLOGY CO.,LTD

TEL : 0755-27129737 FAX : 0755-29940187

-TOLERANCES- UNLESS OTHERWISE SPECIFIED 公差参数表				 		TITLE: 3.00mm Pitch 产品名称: 90° Wafer			
X.X	±0.30	X.X°	±3°	APPD: 核准:	XIE	PART NO: 产品编号: HDGC3030WRA-F-2xXP			
X.XX	±0.30	X.XX°	±2°	CHECK: 校对:	WANG	DATE	SCALE	UNIT	CODE NUMBER
X.XXX	±0.10	X.XXX°	±1°	DRAW: 绘图:	WANG	2015-07-12	4:1	mm	A008

修订 REV	标记 MARK	修改摘要 REVISION DESCRIPTION	签名 SIGNATURE	日期 DATE
AO		NEW RELEASE	WANG	2015-07-12

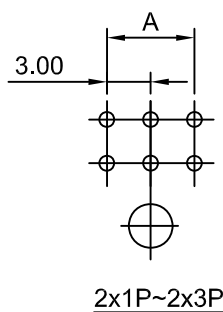
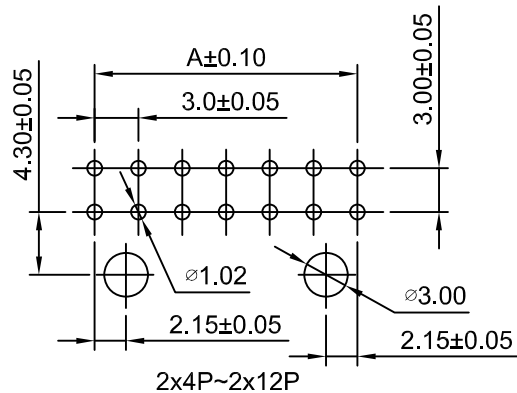
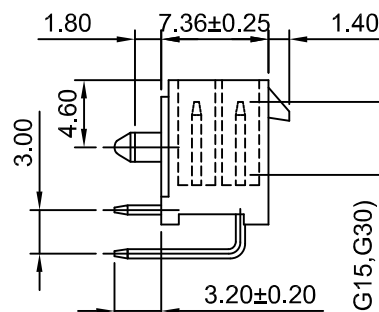
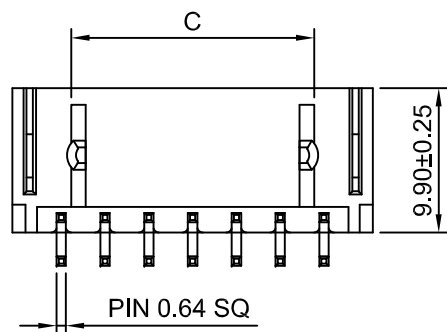
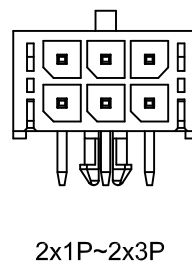
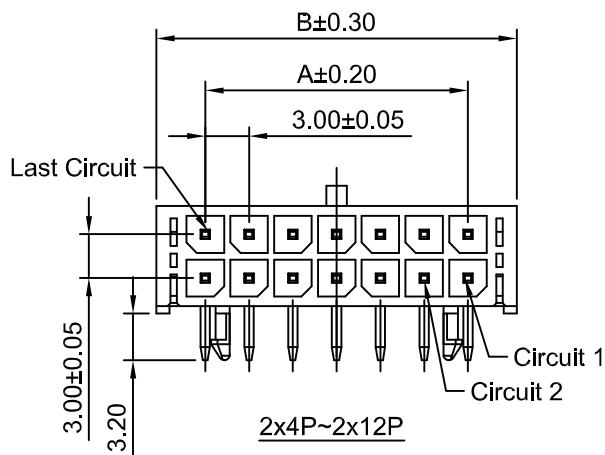

P.C.B LAYOUT

Ordering Information:  
 HDGC3030WRA-F1-2xXP - \*\*  
 1 2

- 1.Part No.  
 2.Finish:  
 (blank):Tin over Nickel  
 G:Gold-flash  
 G15:15μin (0.38μm) MIN.Select Gold  
 100μin (2.54μm) MIN.Select Tin  
 G30:30μin (0.76μm) MIN.Select Gold  
 100μin (2.54μm) MIN.Select Tin

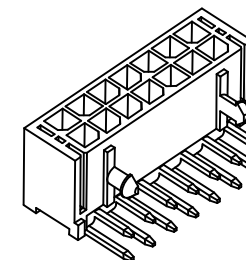

SPECIFICATIONS:

Current Rating: 5A AC,DC  
 Voltage Rating: 250V AC,DC  
 Temperature Range: -25°C ~ +85°C  
 Contact Resistance: 10mΩ Max  
 Insulation Resistance: 1000MΩ Min  
 Withstanding Voltage: 1500V AC/minute  
 Pin Material: Brass/Tin over Nickel  
 Material:Nylon 46,UL94V-0(Black)

Ordering Information & Dimensions

Circuits	Dimensions(mm)			Circuits	Dimensions(mm)		
	A	B	C		A	B	C
2x1P	---	6.70	2.90	2x7P	18.00	24.70	16.60
2x2P	3.00	9.70	2.90	2x8P	21.00	27.70	19.60
2x3P	6.00	12.70	2.90	2x9P	24.00	30.70	22.60
2x4P	9.00	15.70	7.60	2x10P	27.00	33.70	25.60
2x5P	12.00	18.70	10.60	2x11P	30.00	36.70	28.60
2x6P	15.00	21.70	13.60	2x12P	33.00	39.70	31.60



深圳市华德共创科技有限公司

SHENZHEN HUADE CO-CREATE TECHNOLOGY CO.,LTD

TEL : 0755-27129737 FAX : 0755-29940187

-TOLERANCES- UNLESS OTHERWISE SPECIFIED 公差参数表						TITLE: 3.00mm Pitch 产品名称: 90° Wafer	
X.X	±0.30	X.X°	±3°	APPD: 核准:	XIE	PART NO: 产品编号: HDGC3030WRA-F1-2xXP	
X.XX	±0.30	X.XX°	±2°	CHECK: 校对:	WANG	DATE	SCALE
X.XXX	±0.10	X.XXX°	±1°	DRAW: 绘图:	WANG	2015-07-12	2:1
						UNIT	CODE NUMBER
						mm	A008

修订 REV	标记 MARK	修改摘要 REVISION DESCRIPTION	签名 SIGNATURE	日期 DATE
AO		NEW RELEASE	WANG	2017-07-22

Ordering Information:  
**HDGC3030WRA-S-2xXP** - \*\*  
 1 2

- 1.Part No.  
 2.Finish:  
 (blank):Tin over Nickel  
 G:Gold-flash  
 G15:15μin (0.38μm) MIN.Select Gold  
 100μin (2.54μm) MIN.Select Tin  
 G30:30μin (0.76μm) MIN.Select Gold  
 100μin (2.54μm) MIN.Select Tin

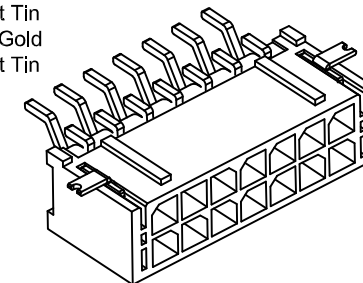

**SPECIFICATIONS:**

Current Rating: 5A AC,DC  
 Voltage Rating: 250V AC,DC  
 Temperature Range: -25°C ~ +85°C  
 Contact Resistance: 10mΩ Max  
 Insulation Resistance: 1000MΩ Min  
 Withstanding Voltage: 1500V AC/minute  
 Pin Material: Brass/Tin over Nickel  
 Material:Nylon 46,UL94V-0(Black)

Ordering Information & Dimensions

Circuits	Dimensions(mm)		Circuits	Dimensions(mm)	
	A	B		A	B
2x1P	---	6.70	2x7P	18.00	24.70
2x2P	3.00	9.70	2x8P	21.00	27.70
2x3P	6.00	12.70	2x9P	24.00	30.70
2x4P	9.00	15.70	2x10P	27.00	33.70
2x5P	12.00	18.70	2x11P	30.00	36.70
2x6P	15.00	21.70	2x12P	33.00	39.70

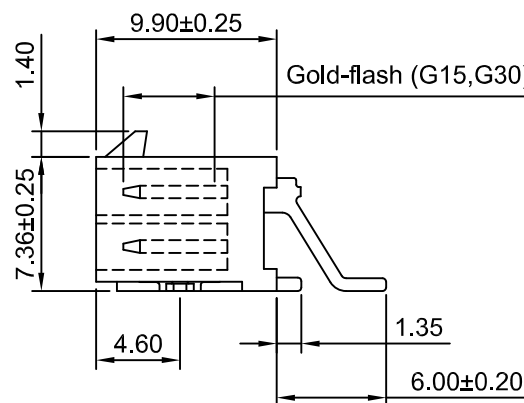
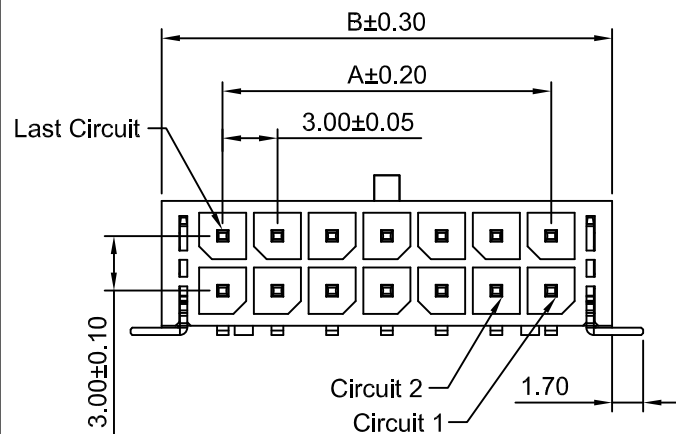
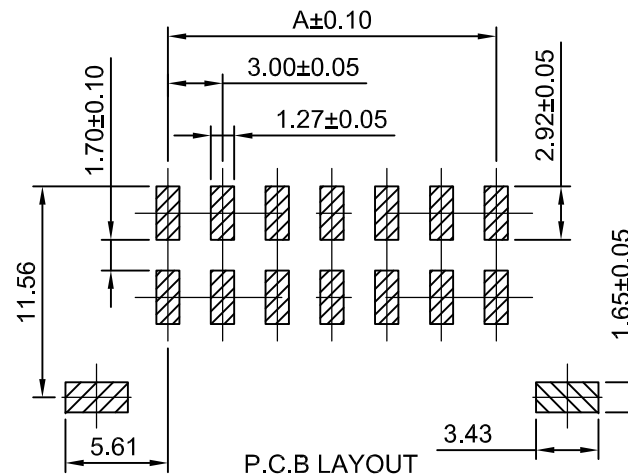
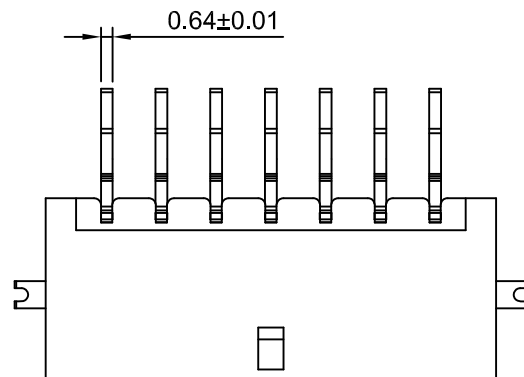

深圳市华德共创科技有限公司

SHENZHEN HUADE CO-CREATE TECHNOLOGY CO.,LTD

TEL : 0755-27129737 FAX : 0755-29940187

-TOLERANCES- UNLESS OTHERWISE SPECIFIED 公差参数表					TITLE: 产品名称: 3.00mm Pitch 90° Wafer	
X.X	±0.30	X.X° ±3°	APPD: 核准:	XIE	PART NO: 产品编号: HDGC3030WRA-S-2xXP	
X.XX	±0.30	X.XX° ±2°	CHECK: 校对:	WANG	DATE	SCALE
X.XXX	±0.10	X.XXX° ±1°	DRAW: 绘图:	WANG	2017-07-22	2.5:1
					UNIT	CODE NUMBER
					mm	A008

修订 REV	标记 MARK	修改摘要 REVISION DESCRIPTION	签名 SIGNATURE	日期 DATE
AO		NEW RELEASE	WANG	2017-07-22

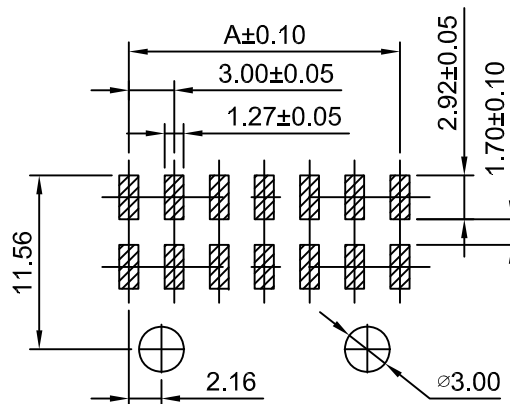
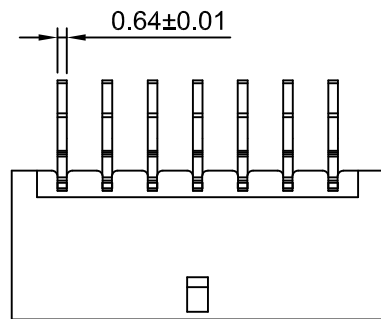

P.C.B LAYOUT  
(2x4P~2x12P)

Ordering Information:  
HDGC3030WRA-S-F1-2xXP - \*\*  
1 2

- 1.Part No.  
2.Finish:  
(blank):Tin over Nickel  
G:Gold-flash  
G15:15μin (0.38μm) MIN.Select Gold  
100μin (2.54μm) MIN.Select Tin  
G30:30μin (0.76μm) MIN.Select Gold  
100μin (2.54μm) MIN.Select Tin

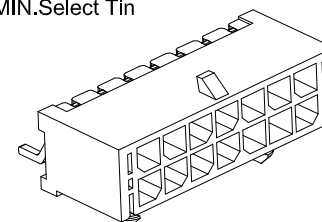

SPECIFICATIONS:

Current Rating: 5A AC,DC  
Voltage Rating: 250V AC,DC  
Temperature Range: -25°C ~ +85°C  
Contact Resistance: 10mΩ Max  
Insulation Resistance: 1000MΩ Min  
Withstanding Voltage: 1500V AC/minute  
Pin Material: Brass/Tin over Nickel  
Material:Nylon LCP, UL94V-0(Black)

Ordering Information & Dimensions

Circuits	Dimensions(mm)		Circuits	Dimensions(mm)	
	A	B		A	B
2x1P	—	6.70	2x7P	18.00	24.70
2x2P	3.00	9.70	2x8P	21.00	27.70
2x3P	6.00	12.70	2x9P	24.00	30.70
2x4P	9.00	15.70	2x10P	27.00	33.70
2x5P	12.00	18.70	2x11P	30.00	36.70
2x6P	15.00	21.70	2x12P	33.00	39.70

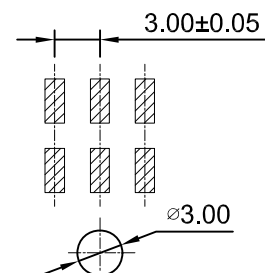
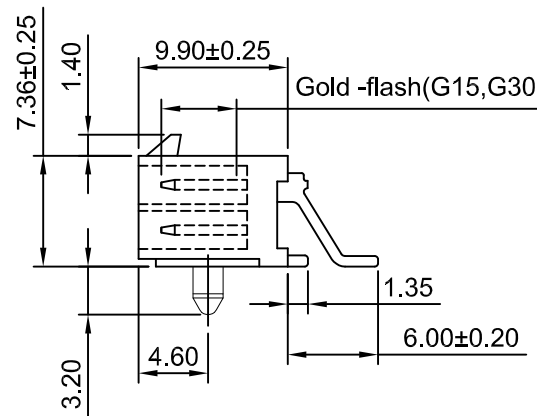
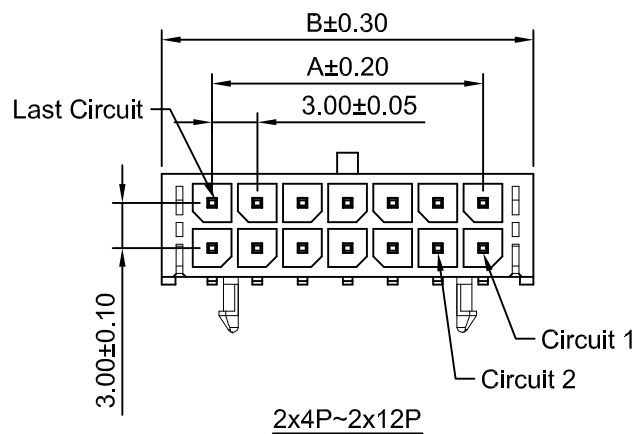

P.C.B LAYOUT  
(2x1P~2x3P)

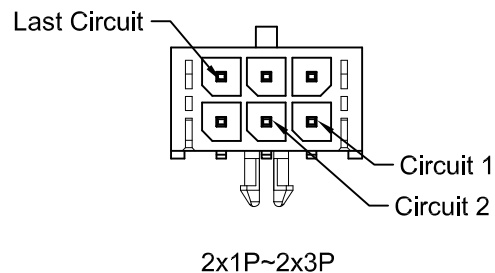

**HDGC** 深圳市华德共创科技有限公司  
SHENZHEN HUADE CO-CREATE TECHNOLOGY CO.,LTD  
TEL : 0755-27129737 FAX : 0755-29940187

-TOLERANCES- UNLESS OTHERWISE SPECIFIED 公差参数表				TITLE: 产品名称: 3.00mm Pitch 90° Wafer	
X.X	±0.30	X.X°	±3°	APPD: 核准:	XIE
X.XX	±0.30	X.XX°	±2°	CHECK: 校对:	WANG
X.XXX	±0.10	X.XXX°	±1°	DRAW: 绘图:	WANG
PART NO: 产品编号:		HDGC3030WRA-S-F1-2xXP			
DATE	SCALE	UNIT	CODE NUMBER		
2017-07-22	2:1	mm	A008		

修订 REV	标记 MARK	修改摘要 REVISION DESCRIPTION	签名 SIGNATURE	日期 DATE
AO		NEW RELEASE	WANG	2017-07-22

**Ordering Information:**

HDGC3030WRA-S-F-2xXP - \*\*  
1 2

1.Part No.

2.Finish:

(blank):Tin over Nickel

G:Gold-flash

G15:15µin (0.38µm) MIN.Select Gold

100µin (2.54µm) MIN.Select Tin

G30:30µin (0.76µm) MIN.Select Gold

100µin (2.54µm) MIN.Select Tin

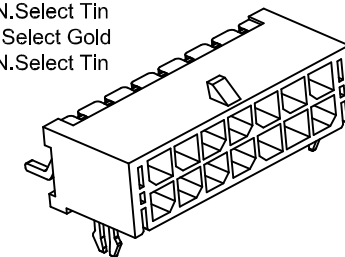

**SPECIFICATIONS:**

Current Rating: 5A AC,DC

Voltage Rating: 250V AC,DC

Temperature Range: -25°C ~ +85°C

Contact Resistance: 10mΩ Max

Insulation Resistance: 1000MΩ Min

Withstanding Voltage: 1500V AC/minute

Pin Material: Brass/Tin over Nickel

Material:Nylon 46,UL94V-0(Black)

**Ordering Information & Dimensions**

Circuits	Dimensions(mm)		Circuits	Dimensions(mm)	
	A	B		A	B
2x1P	---	6.70	2x7P	18.00	24.70
2x2P	3.00	9.70	2x8P	21.00	27.70
2x3P	6.00	12.70	2x9P	24.00	30.70
2x4P	9.00	15.70	2x10P	27.00	33.70
2x5P	12.00	18.70	2x11P	30.00	36.70
2x6P	15.00	21.70	2x12P	33.00	39.70

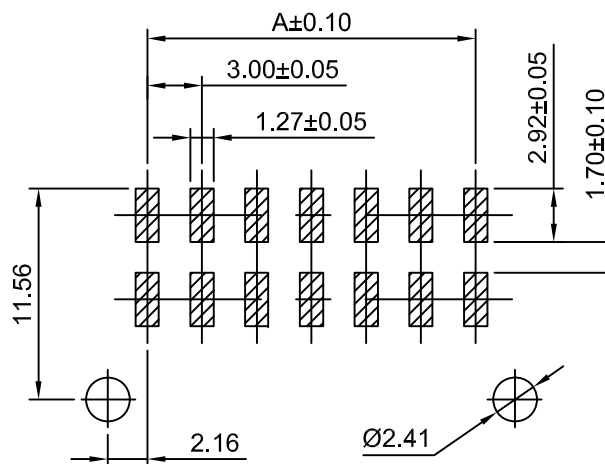
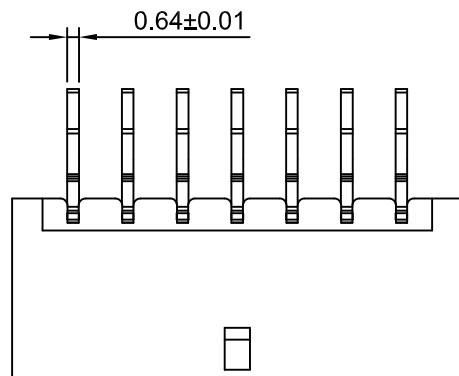

P.C.B LAYOUT

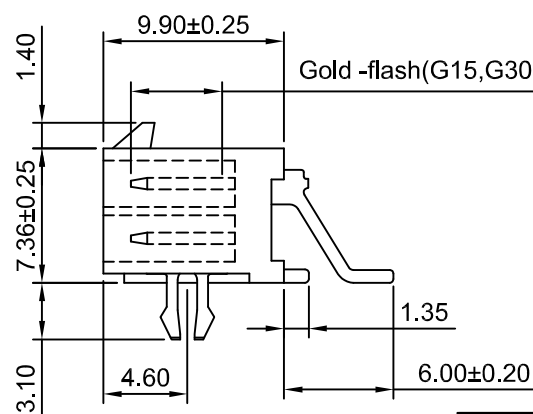
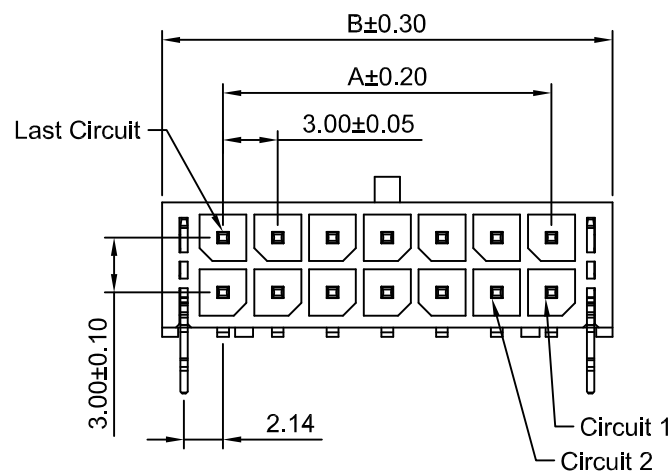

**深圳市华德共创科技有限公司**

SHENZHEN HUADE CO-CREATE TECHNOLOGY CO.,LTD

TEL : 0755-27129737 FAX : 0755-29940187

-TOLERANCES- UNLESS OTHERWISE SPECIFIED 公差参数表						TITLE: 3.00mm Pitch 产品名称: 90° Wafer	
X.X	±0.30	X.X°	±3°	APPD: 核准:	XIE	PART NO: 产品编号: HDGC3030WRA-S-F-2xXP	
X.XX	±0.30	X.XX°	±2°	CHECK: 校对:	WANG	DATE	SCALE
X.XXX	±0.10	X.XXX°	±1°	DRAW: 绘图:	WANG	2017-07-22	2.5:1
				UNIT	mm	CODE NUMBER	A008

修订 REV	标记 MARK	修改摘要 REVISION DESCRIPTION	签名 SIGNATURE	日期 DATE
AO		NEW RELEASE	WANG	2015-07-12

**Ordering Information:**

HDGC3030HFWV-2xXP - \*\* - \*\*  
1 2 3

1.Part No.

2.Material:

(blank):LCP UL94V-0

GWT:LCP UL94V-0,GWT 750°C

3.Finish:

(blank):Tin over Nickel

G:Gold over Nickel(1"U)

G3:Gold over Nickel(3"U)

G15:Gold over Nickel(15"U)

G30:Gold over Nickel(30"U)

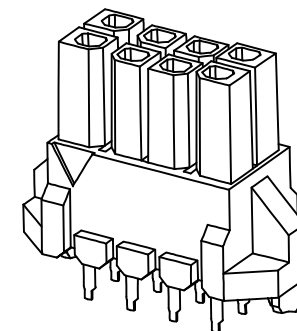

**SPECIFICATIONS:**

Current Rating: 5A AC,DC

Voltage Rating: 250V AC,DC

Temperature Range: -25°C ~ +85°C

Contact Resistance: 10mΩ Max

Insulation Resistance: 1000MΩ Min

Withstanding Voltage: 1500V AC/minute

Pin Material: Phosphor Bronze/Tin over Nickel

Material: LCP,UL94V-0(Black)

**Ordering Information & Dimensions**

Circuits	Dimensions(mm)			Circuits	Dimensions(mm)		
	A	B	C		A	B	C
2x2P	3.00	12.00	9.00	2x8P	21.00	30.00	27.00
2x3P	6.00	15.00	12.00	2x9P	24.00	33.00	30.00
2x4P	9.00	18.00	15.00	2x10P	27.00	36.00	33.00
2x5P	12.00	21.00	18.00	2x11P	30.00	39.00	36.00
2x6P	15.00	24.00	21.00	2x12P	33.00	42.00	39.00
2x7P	18.00	27.00	24.00				

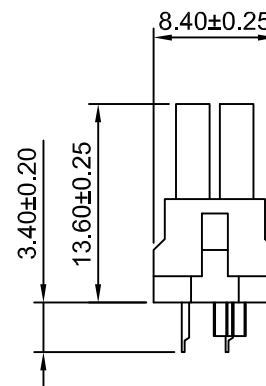
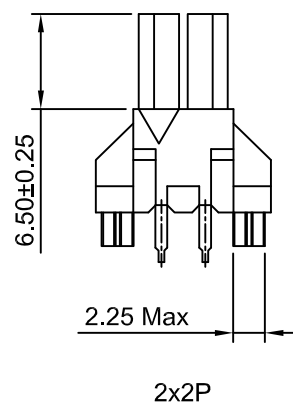
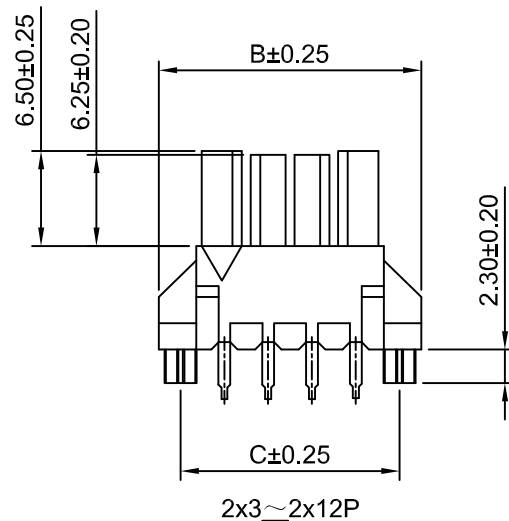
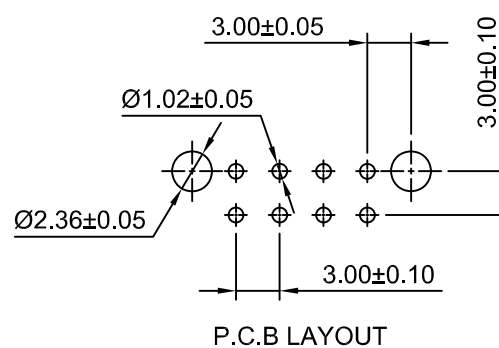
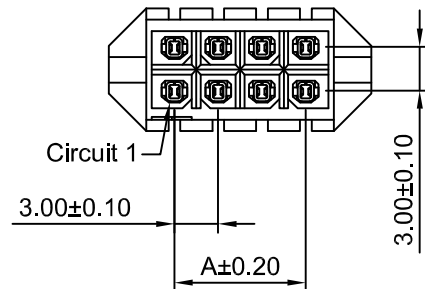

深圳市华德共创科技有限公司

SHENZHEN HUADE CO-CREATE TECHNOLOGY CO.,LTD

TEL : 0755-27129737 FAX : 0755-29940187

-TOLERANCES- UNLESS OTHERWISE SPECIFIED 公差参数表				 		TITLE: 3.00mm Pitch 产品名称: 180° Wafer	
X.X	±0.30	X.X°	±3°	APPD: 核准:	XIE	PART NO: 产品编号: HDGC3030HFWV-2xXP	
X.XX	±0.30	X.XX°	±2°	CHECK: 校对:	WANG	DATE	SCALE
X.XXX	±0.10	X.XXX°	±1°	DRAW: 绘图:	WANG	2015-07-12	2:1
						UNIT	CODE NUMBER
						mm	A008

修订 REV	标记 MARK	修改摘要 REVISION DESCRIPTION	签名 SIGNATURE	日期 DATE
AO		NEW RELEASE	WANG	2015-07-12

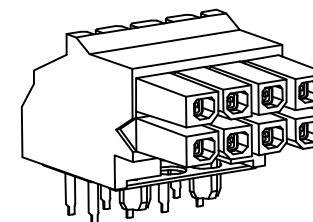
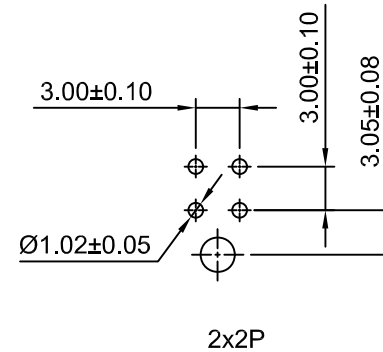
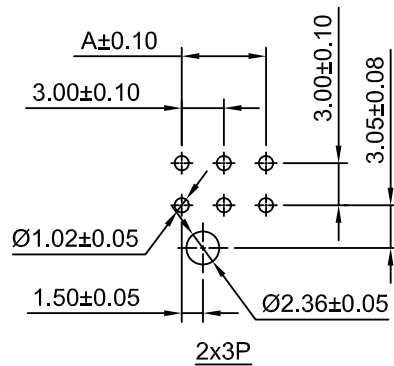
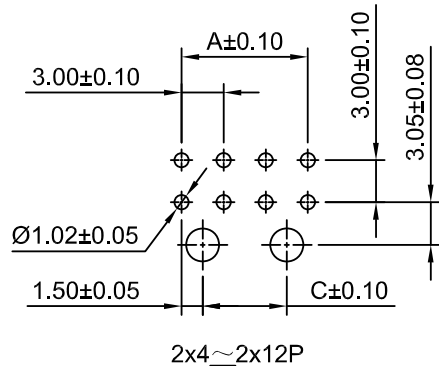

P.C.B LAYOUT

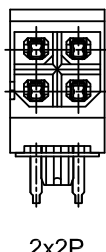
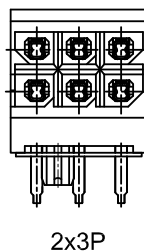
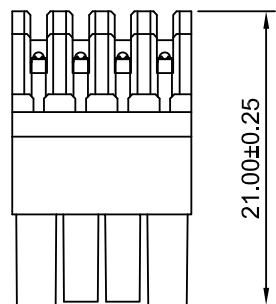

- Ordering Information:  
**HDGC3030HFWR-2xXP** - <sup>\*\*</sup>/<sub>2</sub> - <sup>\*\*</sup>/<sub>3</sub>
- Part No.
  - Material:  
 (blank):LCP UL94V-0  
 GWT:LCP UL94V-0,GWT 750°C
  - Finish:  
 (blank):Tin over Nickel  
 G:Gold over Nickel(1"U)  
 G3:Gold over Nickel(3"U)  
 G15:Gold over Nickel(15"U)  
 G30:Gold over Nickel(30"U)

- SPECIFICATIONS:**  
 Current Rating: 5A AC,DC  
 Voltage Rating: 250V AC,DC  
 Temperature Range: -25°C ~ +85°C  
 Contact Resistance: 10mΩ Max  
 Insulation Resistance: 1000MΩ Min  
 Withstanding Voltage: 1500V AC/minute  
 Pin Material: Phosphor Bronze/Tin over Nickel  
 Material: LCP,UL94-V0(Black)

Ordering Information & Dimensions

Circuits	Dimensions(mm)			Circuits	Dimensions(mm)		
	A	B	C		A	B	C
2x2P	3.00	6.70	---	2x8P	21.00	24.70	18.00
2x3P	6.00	9.70	---	2x9P	24.00	27.70	21.00
2x4P	9.00	12.70	6.00	2x10P	27.00	30.70	24.00
2x5P	12.00	15.70	9.00	2x11P	30.00	33.70	27.00
2x6P	15.00	18.70	12.00	2x12P	33.00	36.70	30.00
2x7P	18.00	21.70	15.00				

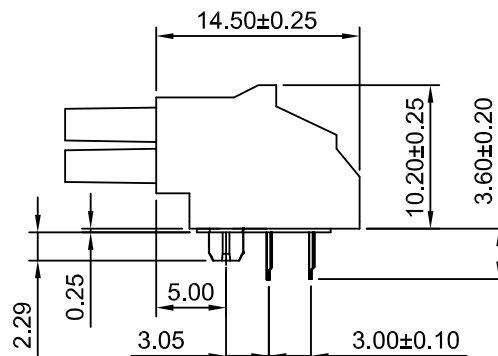
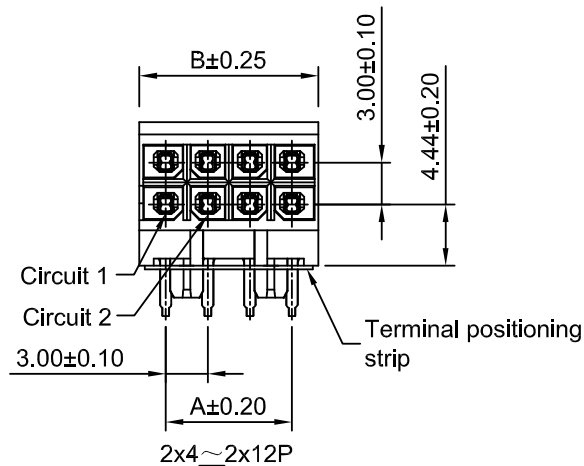

深圳市华德共创科技有限公司

SHENZHEN HUADE CO-CREATE TECHNOLOGY CO.,LTD

TEL : 0755-27129737 FAX : 0755-29940187

-TOLERANCES- UNLESS OTHERWISE SPECIFIED 公差参数表				 		TITLE: 3.00mm Pitch 产品名称: 90° Wafer			
X.X	±0.30	X.X°	±3°	APPD: 核准:	XIE	PART NO: 产品编号: HDGC3030HFWR-2xXP			
X.XX	±0.30	X.XX°	±2°	CHECK: 校对:	WANG	DATE	SCALE	UNIT	CODE NUMBER
X.XXX	±0.10	X.XXX°	±1°	DRAW: 绘图:	WANG	2015-07-12	2:1	mm	A008

修订 REV	标记 MARK	修改摘要 REVISION DESCRIPTION	签名 SIGNATURE	日期 DATE
AO		NEW RELEASE	WANG	2015-07-12

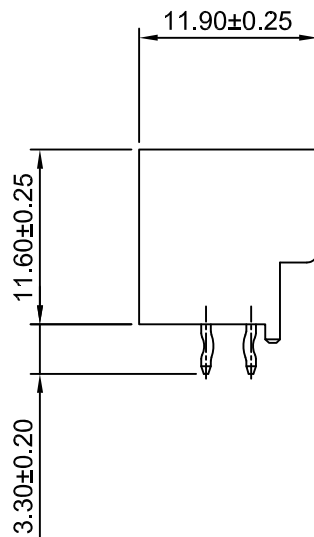
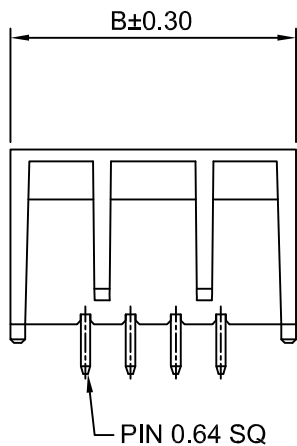
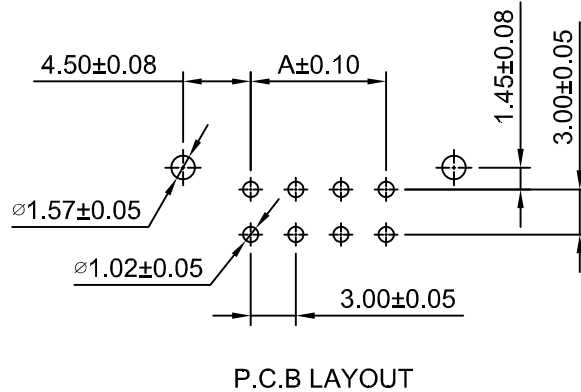
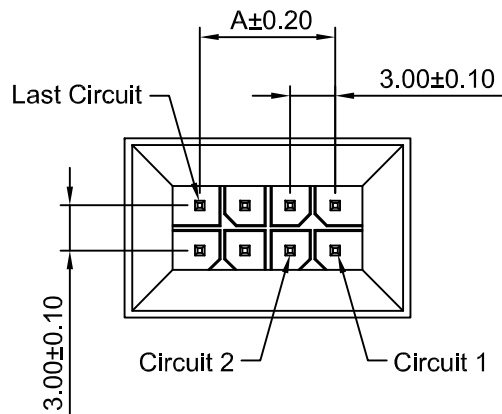

### Ordering Information:

HDGC3030HFWVB-2xXP - \*\* - \*\*\*  
1 2 3

- Part No.
- Material:  
(blank): LCP,UL94V-0  
6T: Nylon 6T,UL94V-0  
9T: Nylon 9T,UL94V-0
- Finish:  
(blank): Tin over Nickel  
G: Gold over Nickel(1"U)  
G3: Gold over Nickel(3"U)  
G15: Gold over Nickel(15"U)  
G30: Gold over Nickel(30"U)

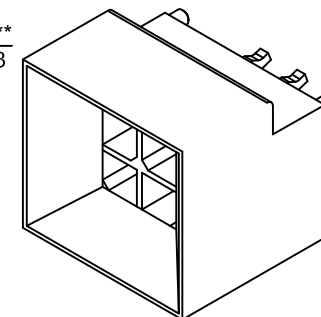

### SPECIFICATIONS:

Current Rating: 8.5A AC,DC (AWG #18)  
Voltage Rating: 250V AC,DC  
Temperature Range: -25°C ~ +85°C  
Contact Resistance: 10mΩ Max  
Insulation Resistance: 1000MΩ Min  
Withstanding Voltage: 1500V AC/minute  
Pin Material: Brass/Tin over Nickel  
Material: LCP,UL94V-0(Black)

### Ordering Information & Dimensions

Circuits	Dimensions(mm)		Circuits	Dimensions(mm)	
	A	B		A	B
2x2P	3.00	13.00	2x8P	21.00	31.00
2x3P	6.00	16.00	2x9P	24.00	34.00
2x4P	9.00	19.00	2x10P	27.00	37.00
2x5P	12.00	22.00	2x11P	30.00	40.00
2x6P	15.00	25.00	2x12P	33.00	43.00
2x7P	18.00	28.00			



深圳市华德共创科技有限公司

SHENZHEN HUADE CO-CREATE TECHNOLOGY CO.,LTD

TEL : 0755-27129737 FAX : 0755-29940187

-TOLERANCES- UNLESS OTHERWISE SPECIFIED 公差参数表				TITLE: 产品名称: 3.00mm Pitch 180° Wafer	
X.X	±0.30	X.X°	±3°	APPD: 核准:	XIE
X.XX	±0.30	X.XX°	±2°	CHECK: 校对:	WANG
X.XXX	±0.10	X.XXX°	±1°	DRAW: 绘图:	WANG
PART NO: 产品编号:		HDGC3030WVB-2xXP			
DATE	SCALE	UNIT	CODE NUMBER		
2015-07-12	2:1	mm	A008		

修订 REV	标记 MARK	修改摘要 REVISION DESCRIPTION	签名 SIGNATURE	日期 DATE
AO		NEW RELEASE	WANG	2019-11-12

**Ordering Information:**

HDGC3030WRB-2xXP - \*\* - \*\*\*  
1 2 3

1.Part No.

2.Material:

(blank): LCP,UL94V-0

6T: Nylon 6T,UL94V-0

9T: Nylon 9T,UL94V-0

3.Finish:

(blank):Tin over Nickel

G:Gold over Nickel(1"U)

G3:Gold over Nickel(3"U)

G15:Gold over Nickel(15"U)

G30:Gold over Nickel(30"U)

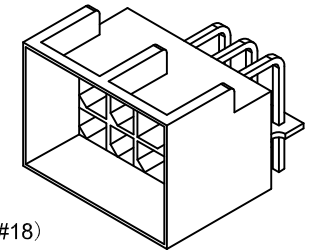

**SPECIFICATIONS:**

Current Rating: 8.5A AC,DC (AWG #18)

Voltage Rating: 250V AC,DC

Temperature Range: -25°C ~ +85°C

Contact Resistance: 10mΩ Max

Insulation Resistance: 1000MΩ Min

Withstanding Voltage: 1500V AC/minute

Pin Material: Brass/Tin over Nickel

Terminal positioning strip:LCP,UL94V-0

Material: LCP,UL94V-0(Black)

**Ordering Information & Dimensions**

Circuits	Dimensions(mm)			Circuits	Dimensions(mm)		
	A	B	C		A	B	C
2x2P	3.00	13.00	—	2x8P	21.00	31.00	16.68
2x3P	6.00	16.00	—	2x9P	24.00	34.00	19.68
2x4P	9.00	19.00	4.68	2x10P	27.00	37.00	22.68
2x5P	12.00	22.00	7.68	2x11P	30.00	40.00	25.68
2x6P	15.00	25.00	10.68	2x12P	33.00	43.00	28.68
2x7P	18.00	28.00	13.68				

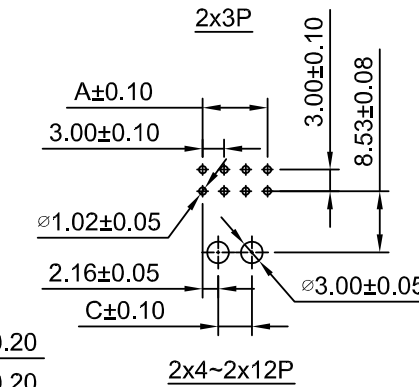
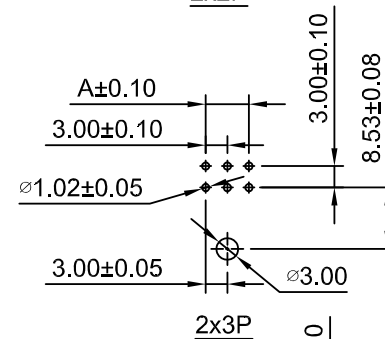
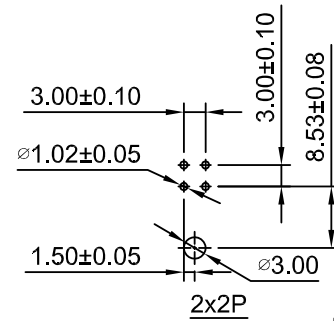
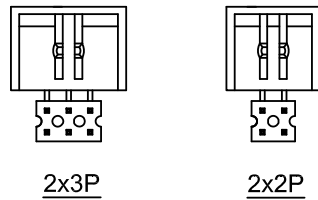
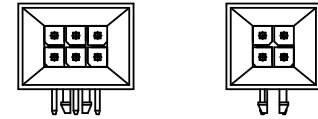
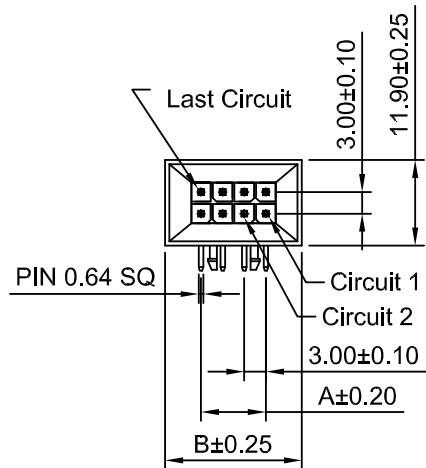

P.C.B LAYOUT

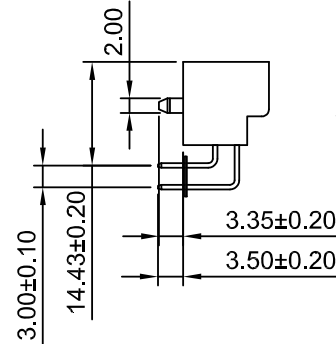
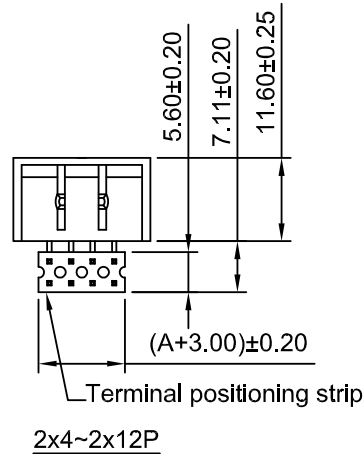

深圳市华德共创科技有限公司

SHENZHEN HUADE CO-CREATE TECHNOLOGY CO.,LTD

TEL : 0755-27129737 FAX : 0755-29940187

-TOLERANCES- UNLESS OTHERWISE SPECIFIED 公差参数表				TITLE: 3.00mm Pitch 产品名称: 90° Wafer	
X.X	±0.30	X.X°	±3°	APPD: 核准:	XIE
X.XX	±0.30	X.XX°	±2°	CHECK: 校对:	WANG
X.XXX	±0.10	X.XXX°	±1°	DRAW: 绘图:	WANG
PART NO: 产品编号:				HDGC3030WRB-2xXP	
DATE		SCALE	UNIT	CODE NUMBER	
2019-11-12		1:1	mm	A008	

修订 REV	标记 MARK	修改摘要 REVISION DESCRIPTION	签名 SIGNATURE	日期 DATE
AO		NEW RELEASE	WANG	2017-07-22

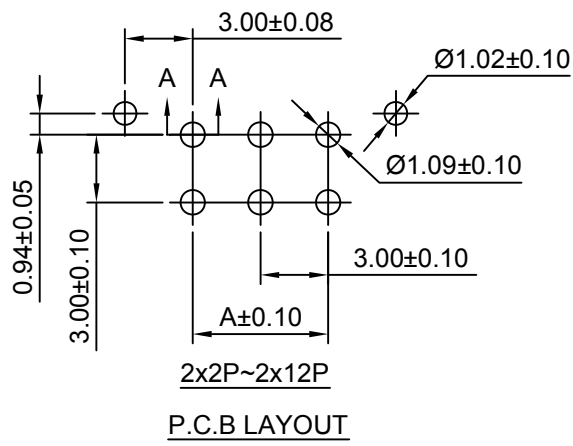
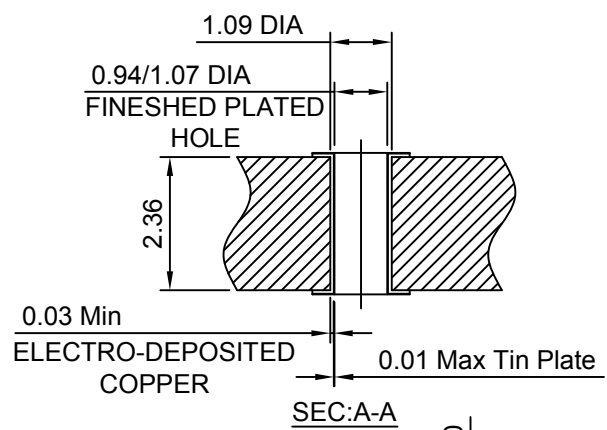

Ordering Information:  
 HDGC3030WVC-2xXP - \*\* - \*\*  
 1 2 3

- Part No.
- Material:  
 (blank):LCP UL94V-0  
 LCP:LCP UL94V-0  
 GWT:LCP UL94V-0,GWT 750°C
- Finish:  
 (blank):Tin over Nickel  
 G:Gold over Nickel(1"U)  
 G3:Gold over Nickel(3"U)  
 G15:Gold over Nickel(15"U)  
 G30:Gold over Nickel(30"U)

**SPECIFICATIONS:**  
 Current Rating: 5A AC,DC  
 Voltage Rating: 250V AC,DC  
 Temperature Range: -25°C ~ +85°C  
 Contact Resistance: 10mΩ Max  
 Insulation Resistance: 1000MΩ Min  
 Withstanding Voltage: 1500V AC/minute  
 Pin Material: Brass/Tin over Nickel  
 Material: LCP,UL94V-0(Black)

Ordering Information & Dimensions

Circuits	Dimensions(mm)		Circuits	Dimensions(mm)	
	A	B		A	B
2x1P	---	6.65	2x7P	18.00	24.65
2x2P	3.00	9.65	2x8P	21.00	27.65
2x3P	6.00	12.65	2x9P	24.00	30.65
2x4P	9.00	15.65	2x10P	27.00	33.65
2x5P	12.00	18.65	2x11P	30.00	36.65
2x6P	15.00	21.65	2x12P	33.00	39.65

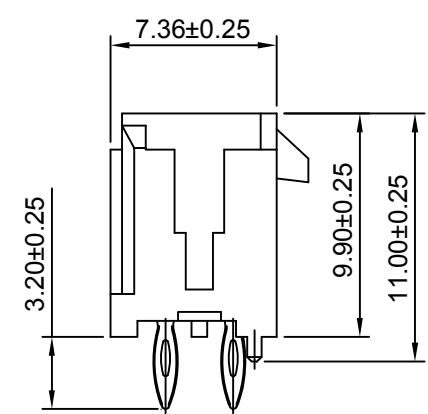
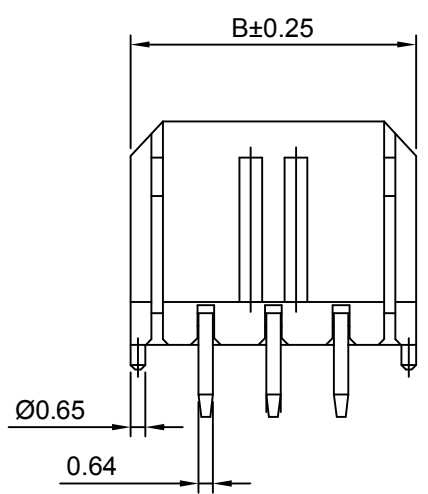
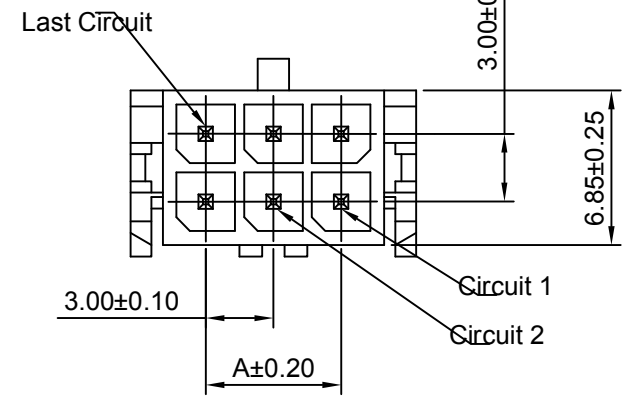
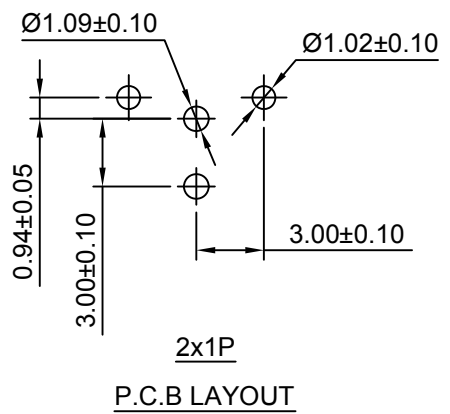

**深圳市华德共创科技有限公司**  
 SHENZHEN HUADE CO-CREATE TECHNOLOGY CO.,LTD  
 TEL : 0755-27129737 FAX : 0755-29940187

-TOLERANCES- UNLESS OTHERWISE SPECIFIED 公差参数表			TITLE: 3.00mm Pitch 产品名称: 180° Wafer	
X.X ±0.30	X.X° ±3°	APPD: 核准: XIE	PART NO: 产品编号: HDGC3030WVC-2xXP	
X.XX ±0.30	X.XX° ±2°	CHECK: 校对: WANG	DATE	SCALE
X.XXX ±0.10	X.XXX° ±1°	DRAW: 绘图: WANG	2017-07-22	3:1
			UNIT	CODE NUMBER
			mm	A008