

修订 REV	标记 MARK	修改摘要 REVISION DESCRIPTION	签名 SIGNATURE	日期 DATE
AO		NEW RELEASE	WANG	2012-12-20

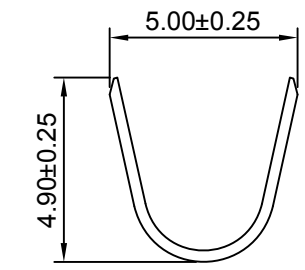

SEC:A-A

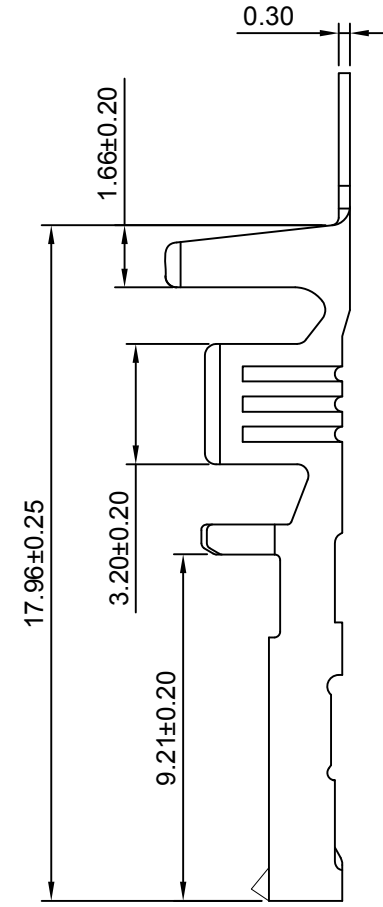
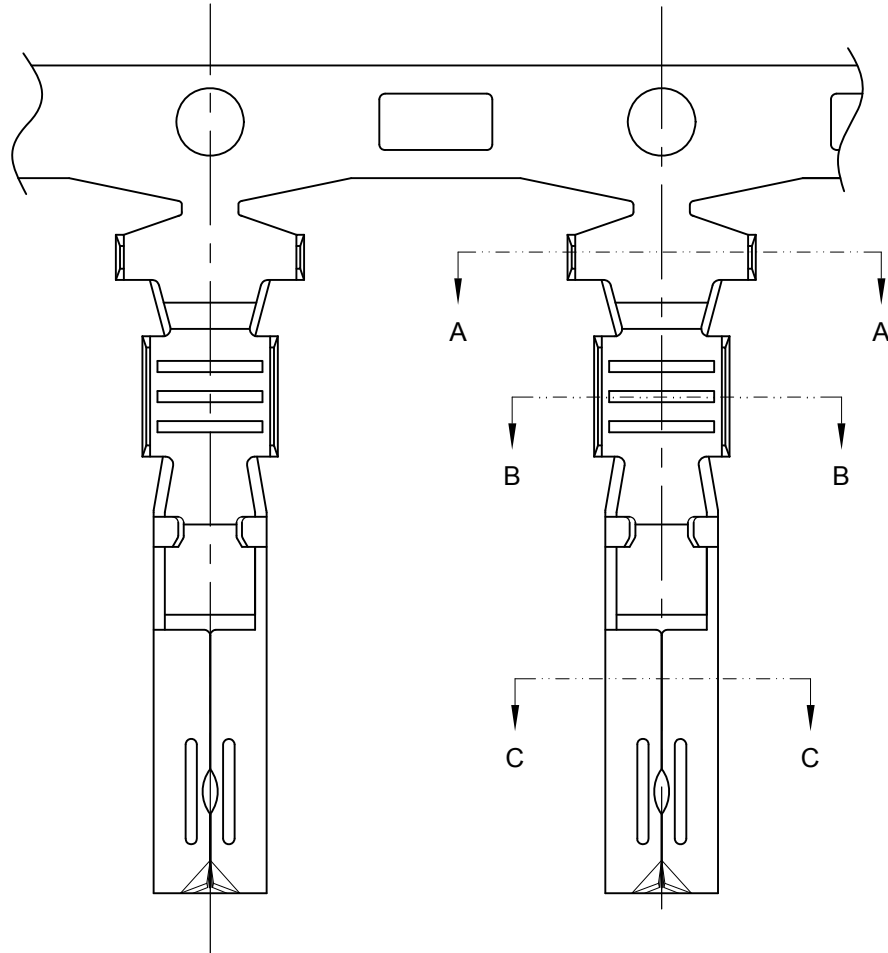
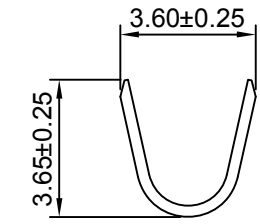

SEC:B-B

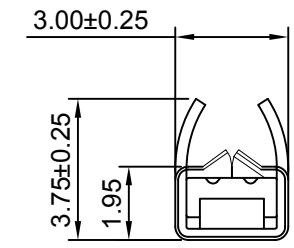

SEC:C-C

Ordering information & Specifications

Unit:mm

Part No	Wire Range	Insultion O.D.	Material	Finish	Qty/reel
HDGC6202F-TP	AWG#14-#18	3.80mm(max)	Phosphor Bronze	Tin over Nickel	2,500 PCS
HDGC6202F-GP	AWG#14-#18	3.80mm(max)	Phosphor Bronze	Gold over Nickel	2,500 PCS

Optional Gold plating available but MOQ requested



深圳市华德共创科技有限公司

SHENZHEN HUADE CO-CREATE TECHNOLOGY CO.,LTD

TEL : 0755-27129737 FAX : 0755-29940187

-TOLERANCES- UNLESS OTHERWISE SPECIFIED 公差参数表						TITLE: 1.80mm Pitch 产品名称: Crimp Terminal			
X.X	±0.30	X.X°	±3°	APPD: 核准:	XIE	PART NO: 产品编号: HDGC6202F-T			
X.XX	±0.30	X.XX°	±2°	CHECK: 校对:	WANG	DATE	SCALE	UNIT	CODE NUMBER
X.XXX	±0.10	X.XXX°	±1°	DRAW: 绘图:	WANG	2012-12-20	5:1	mm	A008

修订 REV	标记 MARK	修改摘要 REVISION DESCRIPTION	签名 SIGNATURE	日期 DATE
AO		NEW RELEASE	WANG	2012-12-20

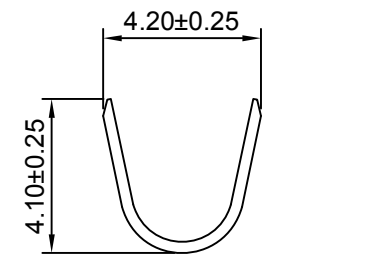
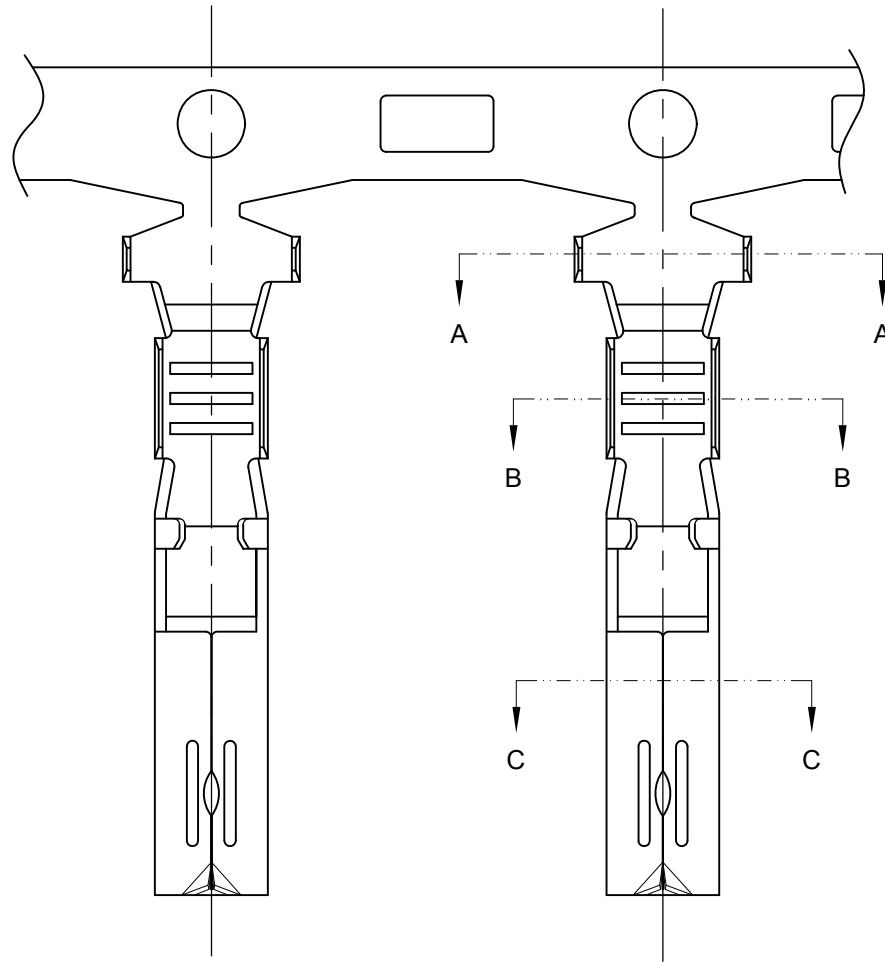

SEC:A-A

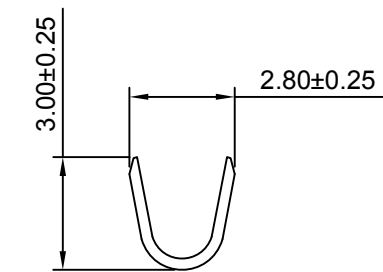

SEC:B-B

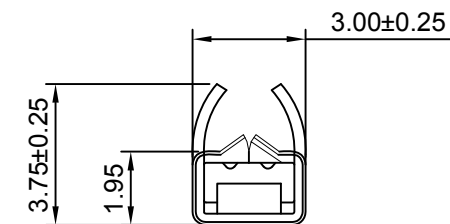

SEC:C-C

Ordering information & Specifications

Unit:mm

Part No	Wire Range	Insultion O.D.	Material	Finish	Qty/reel
HDGC6202F-TP-L	AWG#20-#22	2.70mm(max)	Phosphor Bronze	Tin over Nickel	2,500 PCS
HDGC6202F-GP-L	AWG#20-#22	2.70mm(max)	Phosphor Bronze	Gold over Nickel	2,500 PCS

Optional Gold plating available but MOQ requested



深圳市华德共创科技有限公司

SHENZHEN HUADE CO-CREATE TECHNOLOGY CO.,LTD

TEL : 0755-27129737 FAX : 0755-29940187

-TOLERANCES- UNLESS OTHERWISE SPECIFIED 公差参数表					TITLE: 1.80mm Pitch 产品名称: Crimp Terminal				
X.X	±0.30	X.X°	±3°	APPD: 核准:	XIE				
X.XX	±0.30	X.XX°	±2°	CHECK: 校对:	WANG	DATE	SCALE	UNIT	CODE NUMBER
X.XXX	±0.10	X.XXX°	±1°	DRAW: 绘图:	WANG	2012-12-20	5:1	mm	A008

PART NO: HDGC6202F-T-L
产品编号:

修订 REV	标记 MARK	修改摘要 REVISION DESCRIPTION	签名 SIGNATURE	日期 DATE
AO		NEW RELEASE	WANG	2018-01-12

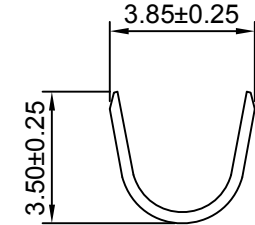
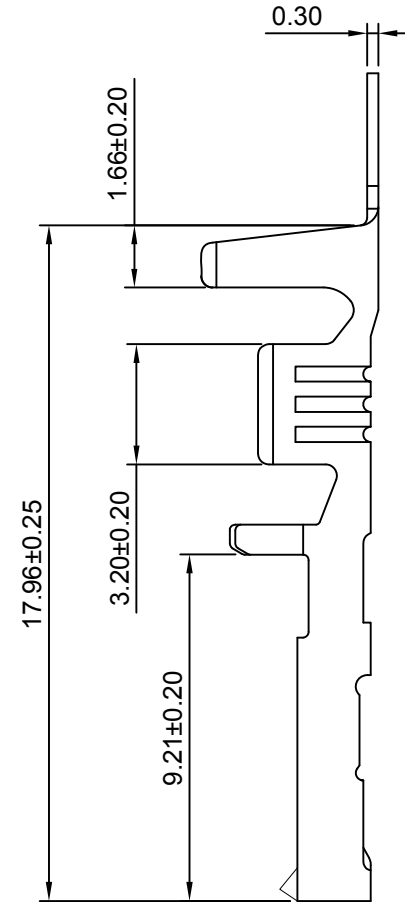
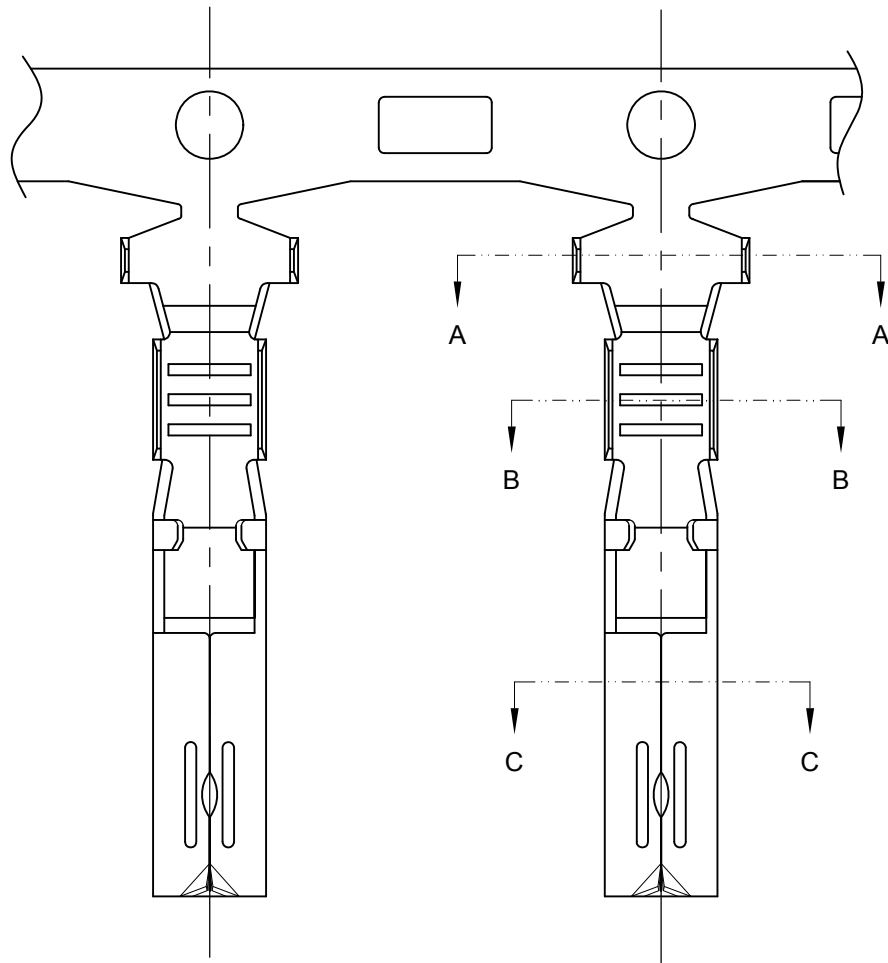

SEC:A-A

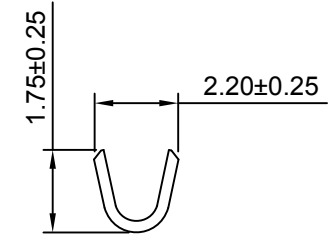

SEC:B-B

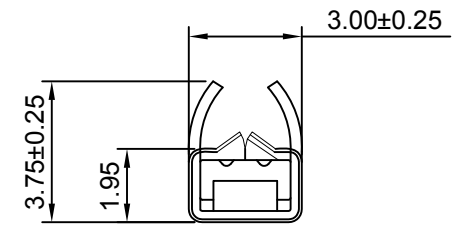

SEC:C-C

Ordering information & Specifications

Unit:mm

Part No	Wire Range	Insultion O.D.	Material	Finish	Qty/reel
HDGC6202F-TP-LL	AWG#24	2.20mm(max)	Phosphor Bronze	Tin over Nickel	2,500 PCS
HDGC6202F-GP-LL	AWG#24	2.20mm(max)	Phosphor Bronze	Gold over Nickel	2,500 PCS

Optional Gold plating available but MOQ requested



深圳市华德共创科技有限公司

SHENZHEN HUADE CO-CREATE TECHNOLOGY CO.,LTD

TEL : 0755-27129737 FAX : 0755-29940187

-TOLERANCES- UNLESS OTHERWISE SPECIFIED 公差参数表					TITLE: 1.80mm Pitch 产品名称: Crimp Terminal				
X.X	±0.30	X.X°	±3°	APPD: 核准:	XIE				
X.XX	±0.30	X.XX°	±2°	CHECK: 校对:	WANG	DATE	SCALE	UNIT	CODE NUMBER
X.XXX	±0.10	X.XXX°	±1°	DRAW: 绘图:	WANG	2018-01-12	5:1	mm	A008

PART NO: HDGC6202F-T-LL
产品编号:

修订 REV	标记 MARK	修改摘要 REVISION DESCRIPTION	签名 SIGNATURE	日期 DATE
AO		NEW RELEASE	WANG	2012-12-20

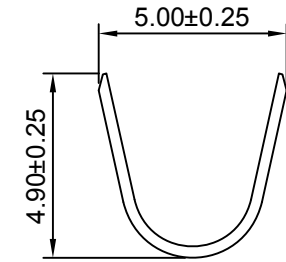
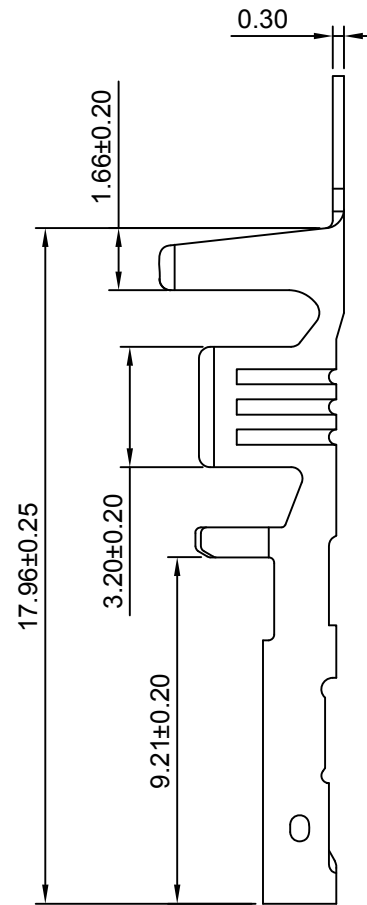
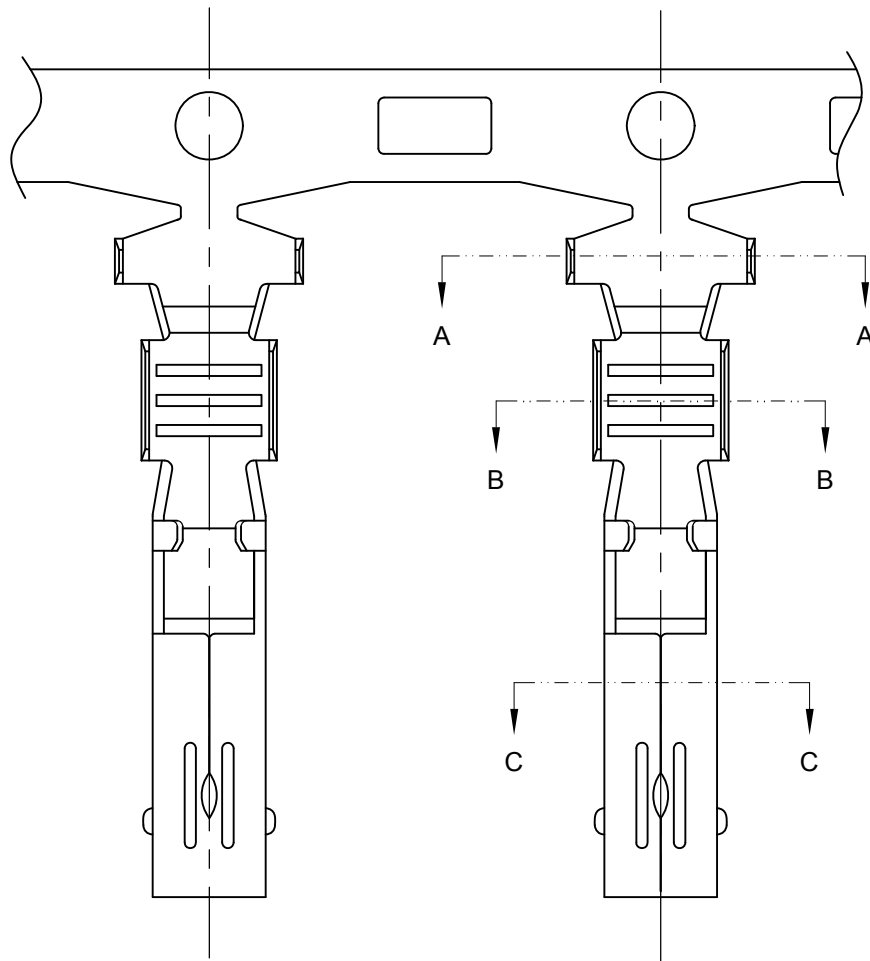

SEC:A-A

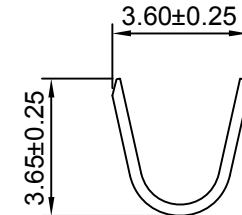

SEC:B-B

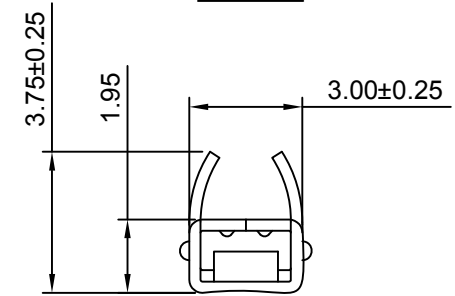

SEC:C-C

Ordering information & Specifications

Unit:mm

Part No	Wire Range	Insultion O.D.	Material	Finish	Qty/reel
HDGC6202FA-TP	AWG#14-#18	3.80mm(max)	Phosphor Bronze	Tin over Nickel	2,500 PCS
HDGC6202FA-GP	AWG#14-#18	3.80mm(max)	Phosphor Bronze	Gold over Nickel	2,500 PCS

Optional Gold plating available but MOQ requested



深圳市华德共创科技有限公司

SHENZHEN HUADE CO-CREATE TECHNOLOGY CO.,LTD

TEL : 0755-27129737 FAX : 0755-29940187

-TOLERANCES- UNLESS OTHERWISE SPECIFIED 公差参数表					TITLE: 1.80mm Pitch 产品名称: Crimp Terminal			
X.X	±0.30	X.X°	±3°	APPD: 核准: XIE	PART NO: 产品编号: HDGC6202FA-T			
X.XX	±0.30	X.XX°	±2°	CHECK: 校对: WANG	DATE	SCALE	UNIT	CODE NUMBER
X.XXX	±0.10	X.XXX°	±1°	DRAW: 绘图: WANG	2012-12-20	5:1	mm	A008

修订 REV	标记 MARK	修改摘要 REVISION DESCRIPTION	签名 SIGNATURE	日期 DATE
AO		NEW RELEASE	WANG	2012-12-20

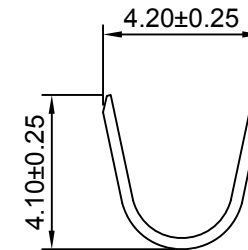
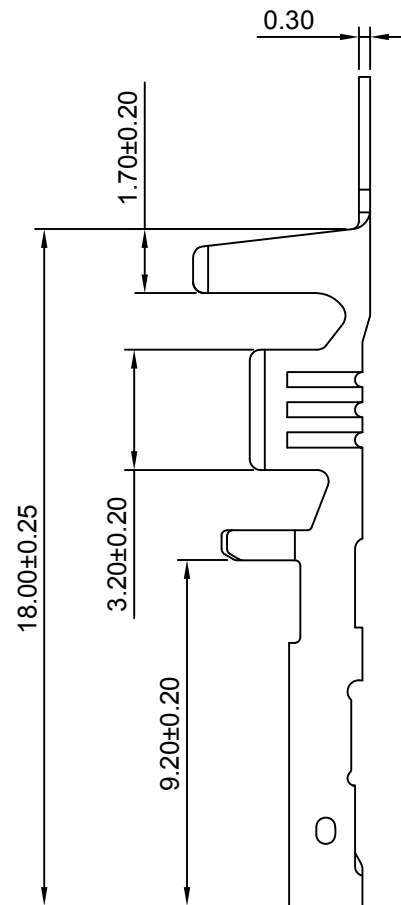
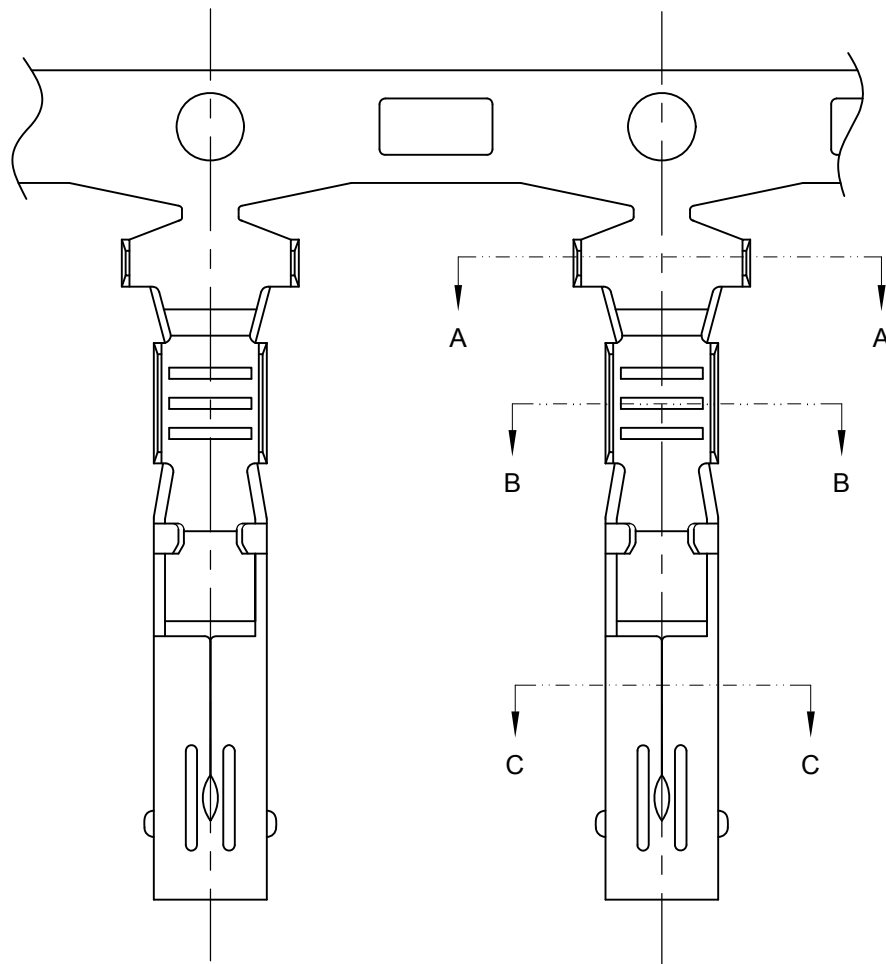

SEC:A-A

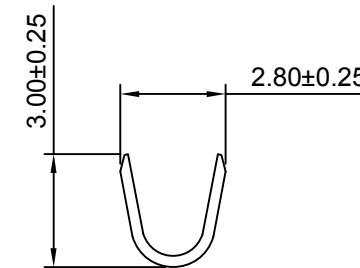

SEC:B-B

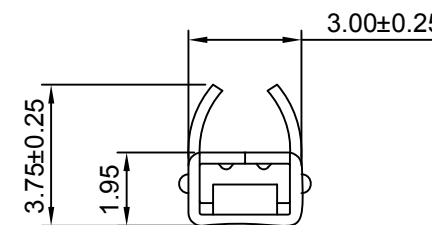

SEC:C-C

Ordering information & Specifications

Unit:mm

Part No	Wire Range	Insulation O.D.	Material	Finish	Qty/reel
HDGC6202FA-TP-L	AWG#20-#22	2.70mm(max)	Phosphor Bronze	Tin over Nickel	2,500 PCS
HDGC6202FA-GP-L	AWG#20-#22	2.70mm(max)	Phosphor Bronze	Gold over Nickel	2,500 PCS

Optional Gold plating available but MOQ requested



深圳市华德共创科技有限公司

SHENZHEN HUADE CO-CREATE TECHNOLOGY CO.,LTD

TEL : 0755-27129737 FAX : 0755-29940187

-TOLERANCES- UNLESS OTHERWISE SPECIFIED 公差参数表						TITLE: 1.80mm Pitch 产品名称: Crimp Terminal			
X.X	±0.30	X.X°	±3°	APPD: 核准:	XIE	PART NO: 产品编号: HDGC6202FA-T-L			
X.XX	±0.30	X.XX°	±2°	CHECK: 校对:	WANG	DATE	SCALE	UNIT	CODE NUMBER
X.XXX	±0.10	X.XXX°	±1°	DRAW: 绘图:	WANG	2012-12-20	5:1	mm	A008

修订 REV	标记 MARK	修改摘要 REVISION DESCRIPTION	签名 SIGNATURE	日期 DATE
AO		NEW RELEASE	WANG	2018-01-12

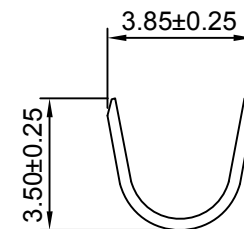
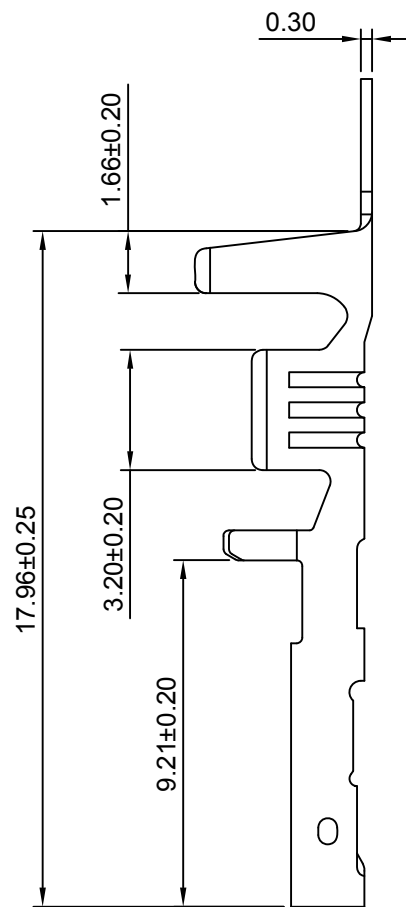
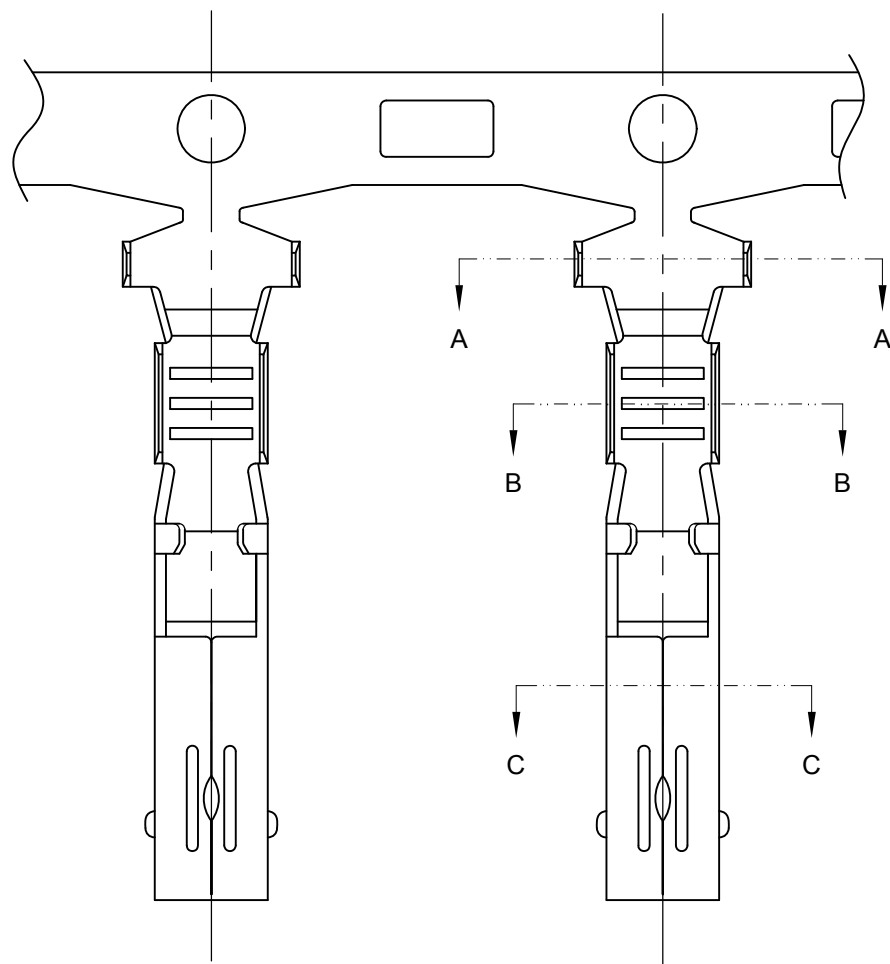

SEC:A-A

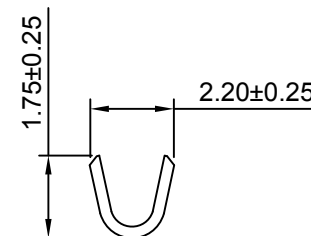

SEC:B-B

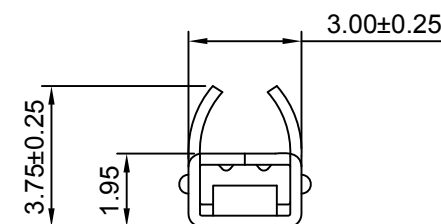

SEC:C-C

Ordering information & Specifications

Unit:mm

Part No	Wire Range	Insultion O.D.	Material	Finish	Qty/reel
HDGC6202FA-TP-LL	AWG#24	2.20mm(max)	Phosphor Bronze	Tin over Nickel	2,500 PCS
HDGC6202FA-GP-LL	AWG#24	2.20mm(max)	Phosphor Bronze	Gold over Nickel	2,500 PCS

Optional Gold plating available but MOQ requested



深圳市华德共创科技有限公司

SHENZHEN HUADE CO-CREATE TECHNOLOGY CO.,LTD

TEL : 0755-27129737 FAX : 0755-29940187

-TOLERANCES- UNLESS OTHERWISE SPECIFIED 公差参数表					TITLE: 1.80mm Pitch 产品名称: Crimp Terminal				
X.X	±0.30	X.X°	±3°	APPD: 核准:	XIE				
X.XX	±0.30	X.XX°	±2°	CHECK: 校对:	WANG	DATE	SCALE	UNIT	CODE NUMBER
X.XXX	±0.10	X.XXX°	±1°	DRAW: 绘图:	WANG	2018-01-12	5:1	mm	A008

PART NO: HDGC6202FA-T-LL
产品编号:

修订 REV	标记 MARK	修改摘要 REVISION DESCRIPTION	签名 SIGNATURE	日期 DATE
AO		NEW RELEASE	WANG	2012-12-20

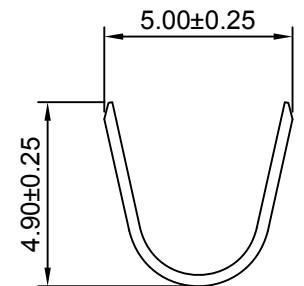
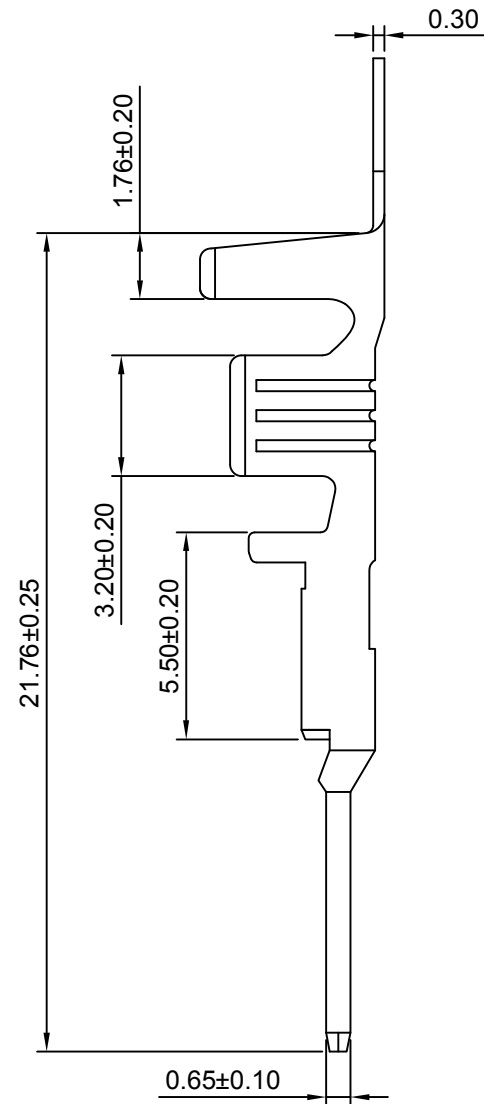
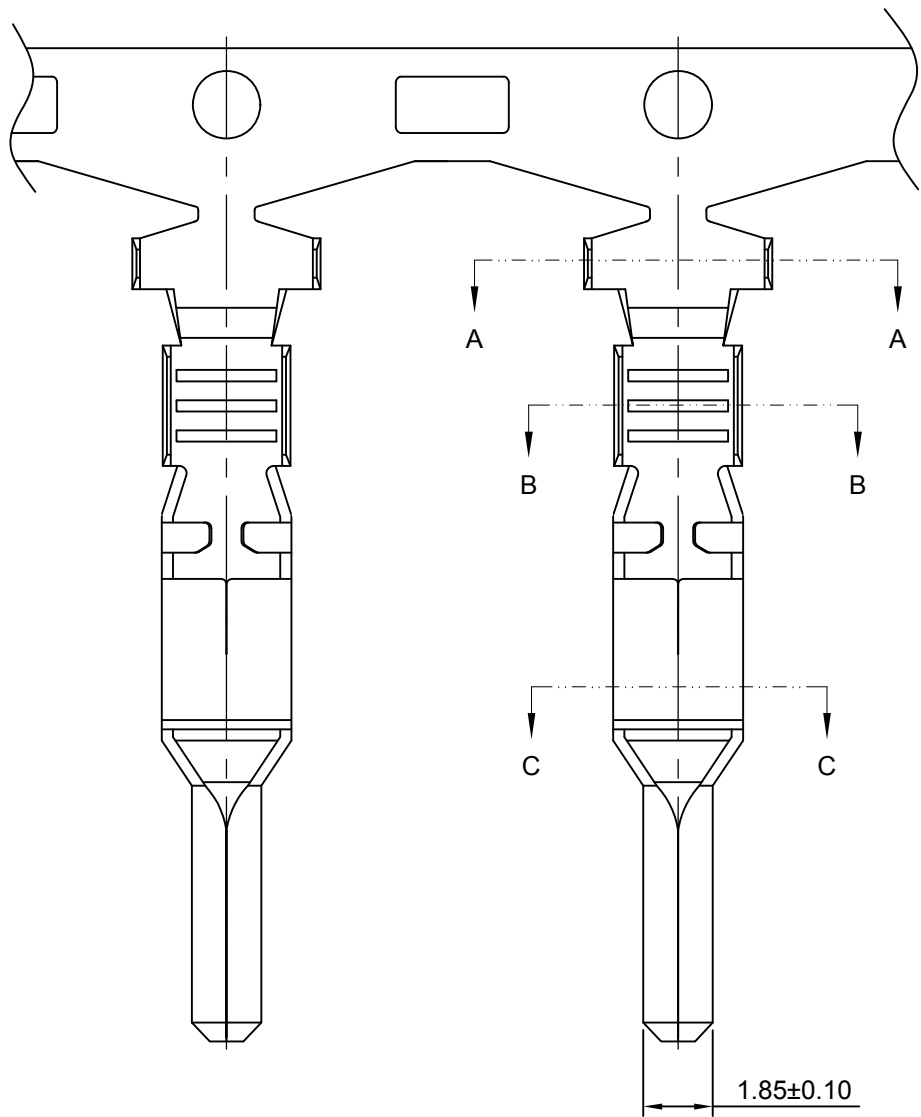

SEC:A-A

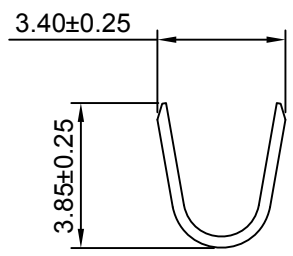

SEC:B-B

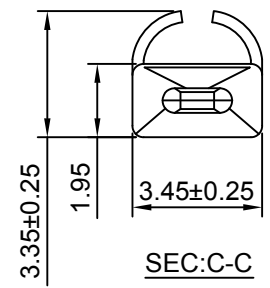

SEC:C-C

Ordering information & Specifications

Unit:mm

Part No	Wire Range	Insultion O.D.	Material	Finish	Qty/reel
HDGC6202M-TP	AWG#14-#18	3.80mm(max)	Phosphor Bronze	Tin over Nickel	2,500 PCS
HDGC6202M-GP	AWG#14-#18	3.80mm(max)	Phosphor Bronze	Gold over Nickel	2,500 PCS

Optional Gold plating available but MOQ requested



深圳市华德共创科技有限公司

SHENZHEN HUADE CO-CREATE TECHNOLOGY CO.,LTD

TEL : 0755-27129737 FAX : 0755-29940187

-TOLERANCES- UNLESS OTHERWISE SPECIFIED 公差参数表				TITLE: 产品名称: 1.80mm Pitch Crimp Terminal	
X.X	±0.30	X.X°	±3°	APPD: 核准: XIE	PART NO: 产品编号: HDGC6202M-T
X.XX	±0.30	X.XX°	±2°	CHECK: 校对: WANG	DATE
X.XXX	±0.10	X.XXX°	±1°	DRAW: 绘图: WANG	SCALE
					UNIT
					CODE NUMBER
					A008

修订 REV	标记 MARK	修改摘要 REVISION DESCRIPTION	签名 SIGNATURE	日期 DATE
AO		NEW RELEASE	WANG	2012-12-20

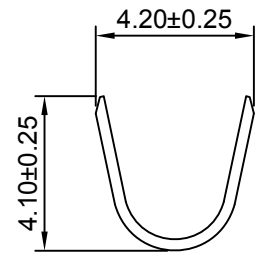
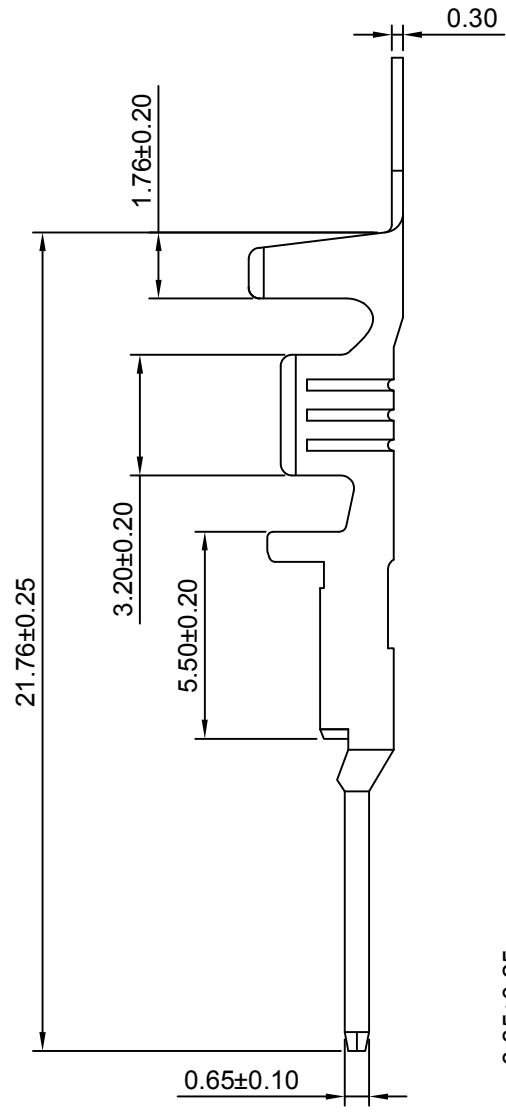
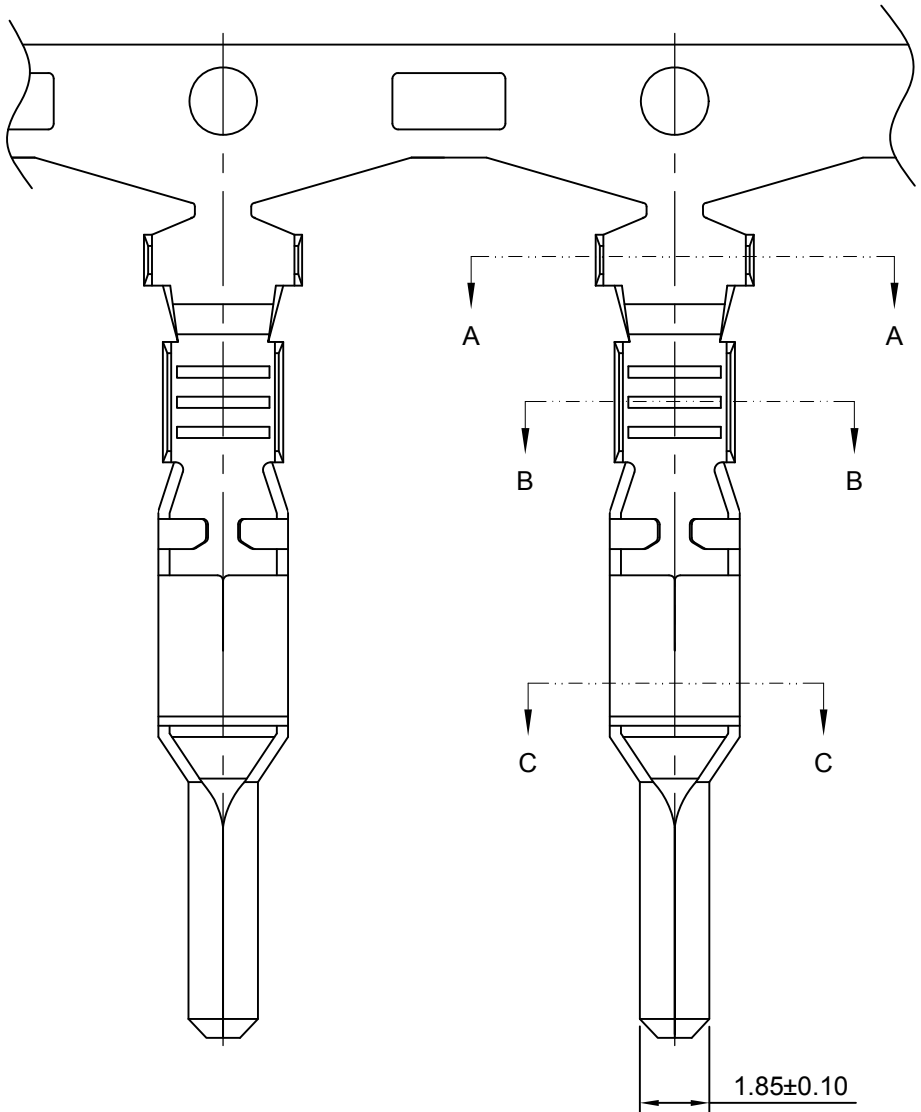

SEC:A-A

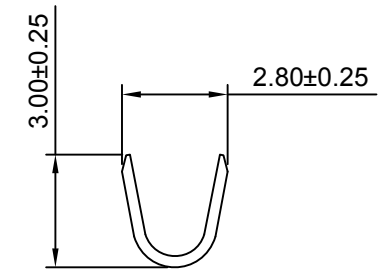

SEC:B-B

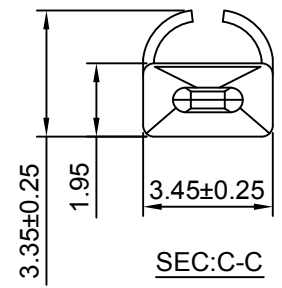

SEC:C-C

Ordering information & Specifications

Unit:mm

Part No	Wire Range	Insultion O.D.	Material	Finish	Qty/reel
HDGC6202M-TP-L	AWG#20-#22	2.70mm(max)	Phosphor Bronze	Tin over Nickel	2,500 PCS
HDGC6202M-GP-L	AWG#20-#22	2.70mm(max)	Phosphor Bronze	Gold over Nickel	2,500 PCS

Optional Gold plating available but MOQ requested



深圳市华德共创科技有限公司

SHENZHEN HUADE CO-CREATE TECHNOLOGY CO.,LTD
TEL : 0755-27129737 FAX : 0755-29940187

-TOLERANCES- UNLESS OTHERWISE SPECIFIED 公差参数表						TITLE: 1.80mm Pitch 产品名称: Crimp Terminal			
X.X	±0.30	X.X°	±3°	APPD: 核准:	XIE	PART NO: 产品编号: HDGC6202M-T-L			
X.XX	±0.30	X.XX°	±2°	CHECK: 校对:	WANG	DATE	SCALE	UNIT	CODE NUMBER
X.XXX	±0.10	X.XXX°	±1°	DRAW: 绘图:	WANG	2012-12-20	5:1	mm	A008

修订 REV	标记 MARK	修改摘要 REVISION DESCRIPTION	签名 SIGNATURE	日期 DATE
AO		NEW RELEASE	WANG	2018-01-12

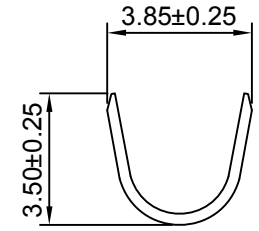
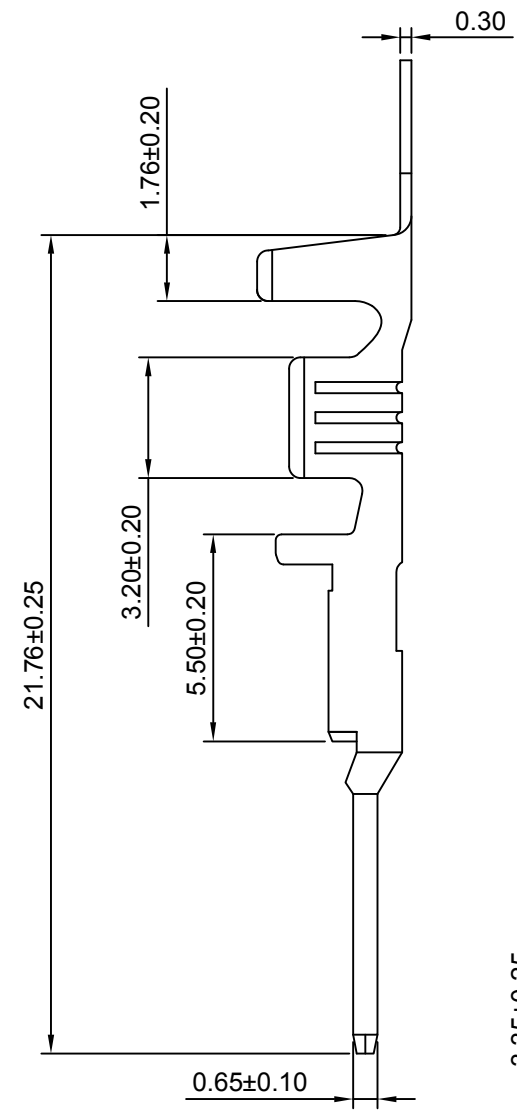
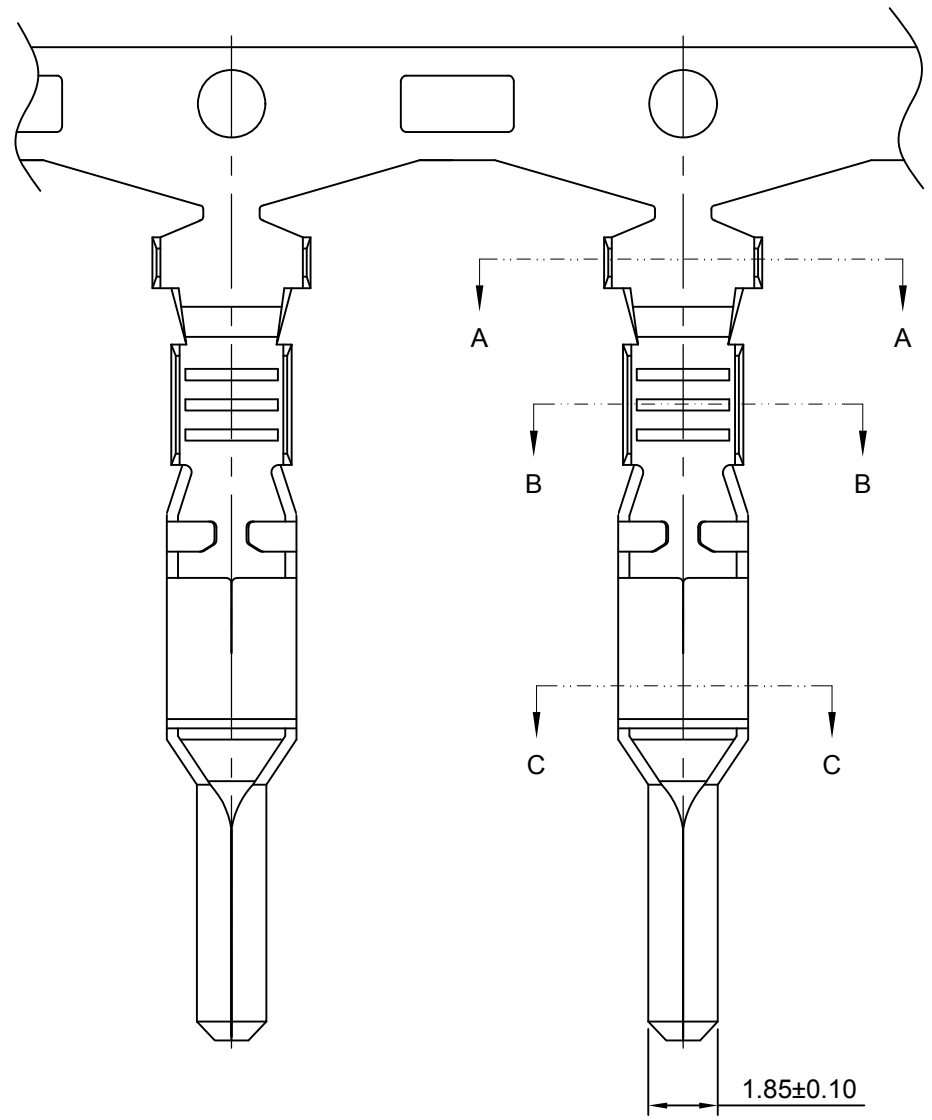

SEC:A-A

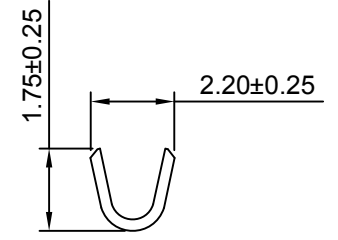

SEC:B-B

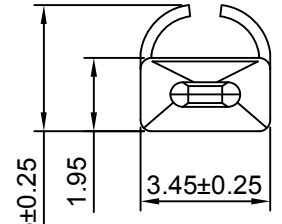

SEC:C-C

Ordering information & Specifications

Unit:mm

Part No	Wire Range	Insulation O.D.	Material	Finish	Qty/reel
HDGC6202M-TP-LL	AWG#24	2.20mm(max)	Phosphor Bronze	Tin over Nickel	2,500 PCS
HDGC6202M-GP-LL	AWG#24	2.20mm(max)	Phosphor Bronze	Gold over Nickel	2,500 PCS

Optional Gold plating available but MOQ requested



深圳市华德共创科技有限公司

SHENZHEN HUADE CO-CREATE TECHNOLOGY CO.,LTD
TEL : 0755-27129737 FAX : 0755-29940187

-TOLERANCES- UNLESS OTHERWISE SPECIFIED 公差参数表						TITLE: 1.80mm Pitch 产品名称: Crimp Terminal			
X.X	±0.30	X.X°	±3°	APPD: 核准:	XIE	PART NO: 产品编号: HDGC6202M-T-LL			
X.XX	±0.30	X.XX°	±2°	CHECK: 校对:	WANG	DATE	SCALE	UNIT	CODE NUMBER
X.XXX	±0.10	X.XXX°	±1°	DRAW: 绘图:	WANG	2018-01-12	5:1	mm	A008

修订 REV	标记 MARK	修改摘要 REVISION DESCRIPTION	签名 SIGNATURE	日期 DATE
AO		NEW RELEASE	WANG	2012-12-20

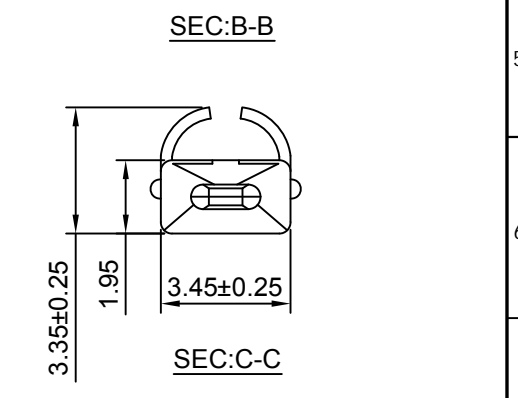
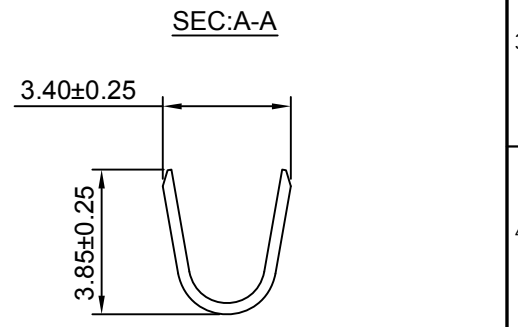
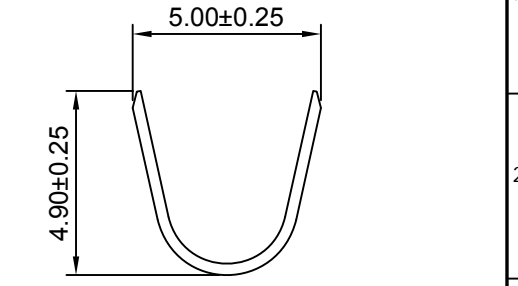
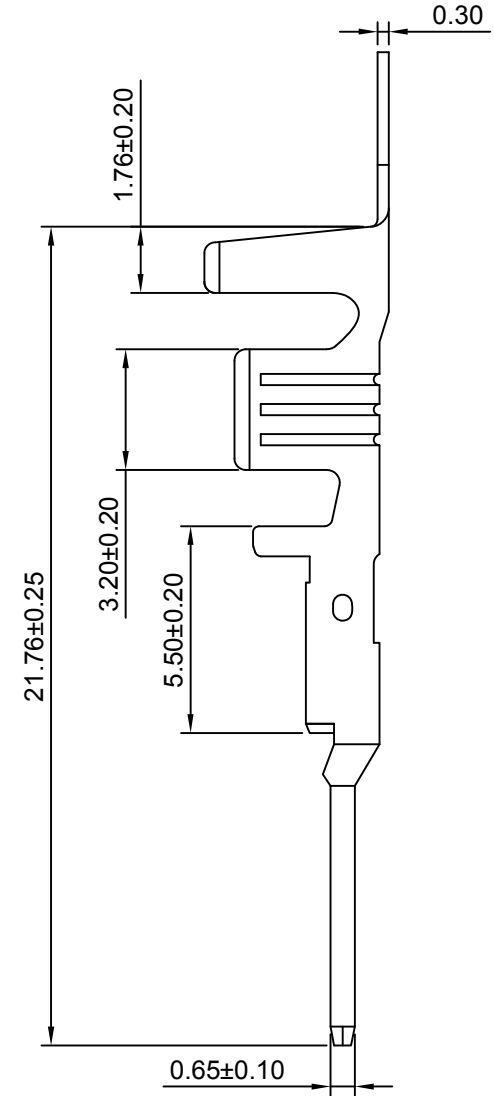
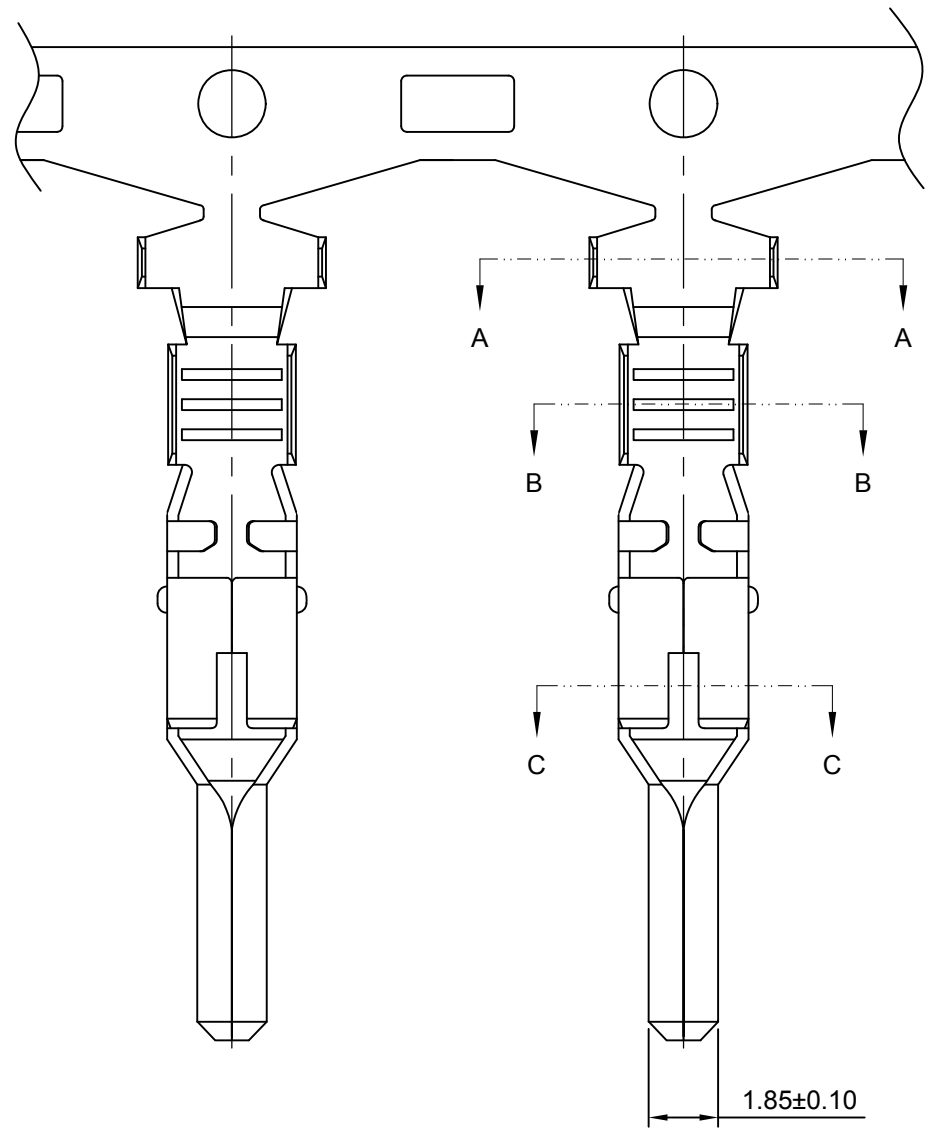

Ordering information & Specifications

Unit:mm

Part No	Wire Range	Insultion O.D.	Material	Finish	Qty/reel
HDGC6202MA-TP	AWG#14-#18	3.80mm(max)	Phosphor Bronze	Tin over Nickel	2,500 PCS
HDGC6202MA-GP	AWG#14-#18	3.80mm(max)	Phosphor Bronze	Gold over Nickel	2,500 PCS

Optional Gold plating available but MOQ requested

HDGC 深圳市华德共创科技有限公司
 SHENZHEN HUADE CO-CREATE TECHNOLOGY CO.,LTD
 TEL : 0755-27129737 FAX : 0755-29940187

-TOLERANCES- UNLESS OTHERWISE SPECIFIED 公差参数表					TITLE: 1.80mm Pitch 产品名称: Crimp Terminal				
X.X	± 0.30	X.X°	$\pm 3^\circ$	APPD: 核准:	XIE				
X.XX	± 0.30	X.XX°	$\pm 2^\circ$	CHECK: 校对:	WANG	DATE	SCALE	UNIT	CODE NUMBER
X.XXX	± 0.10	X.XXX°	$\pm 1^\circ$	DRAW: 绘图:	WANG	2012-12-20	5:1	mm	A008

修订 REV	标记 MARK	修改摘要 REVISION DESCRIPTION	签名 SIGNATURE	日期 DATE
AO		NEW RELEASE	WANG	2012-12-20

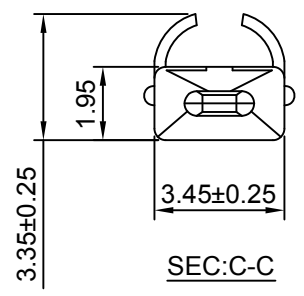
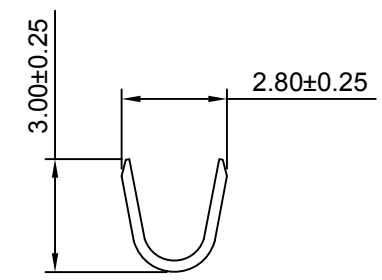
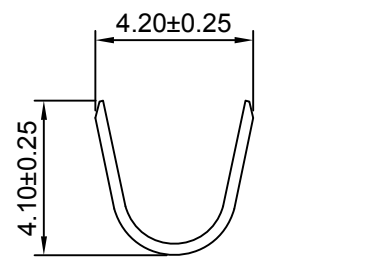
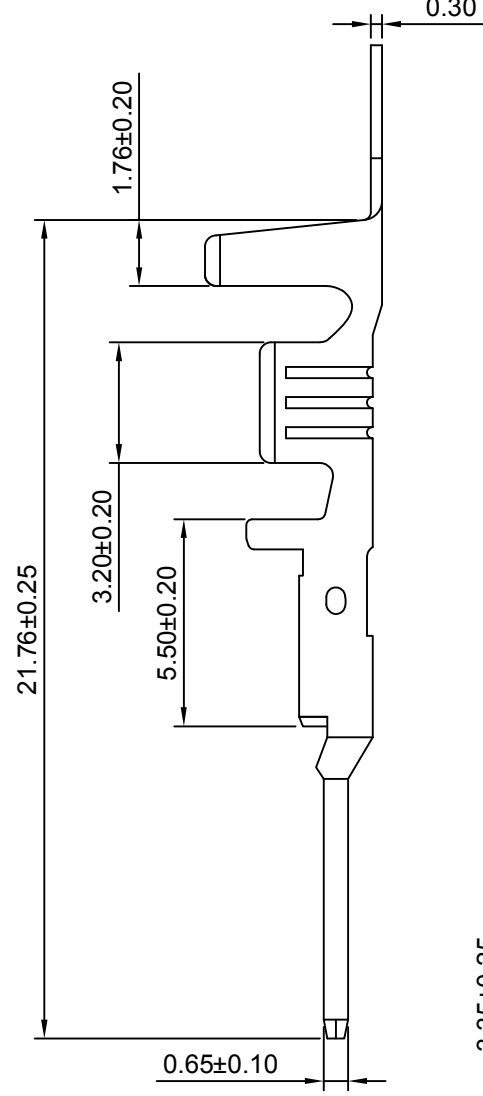
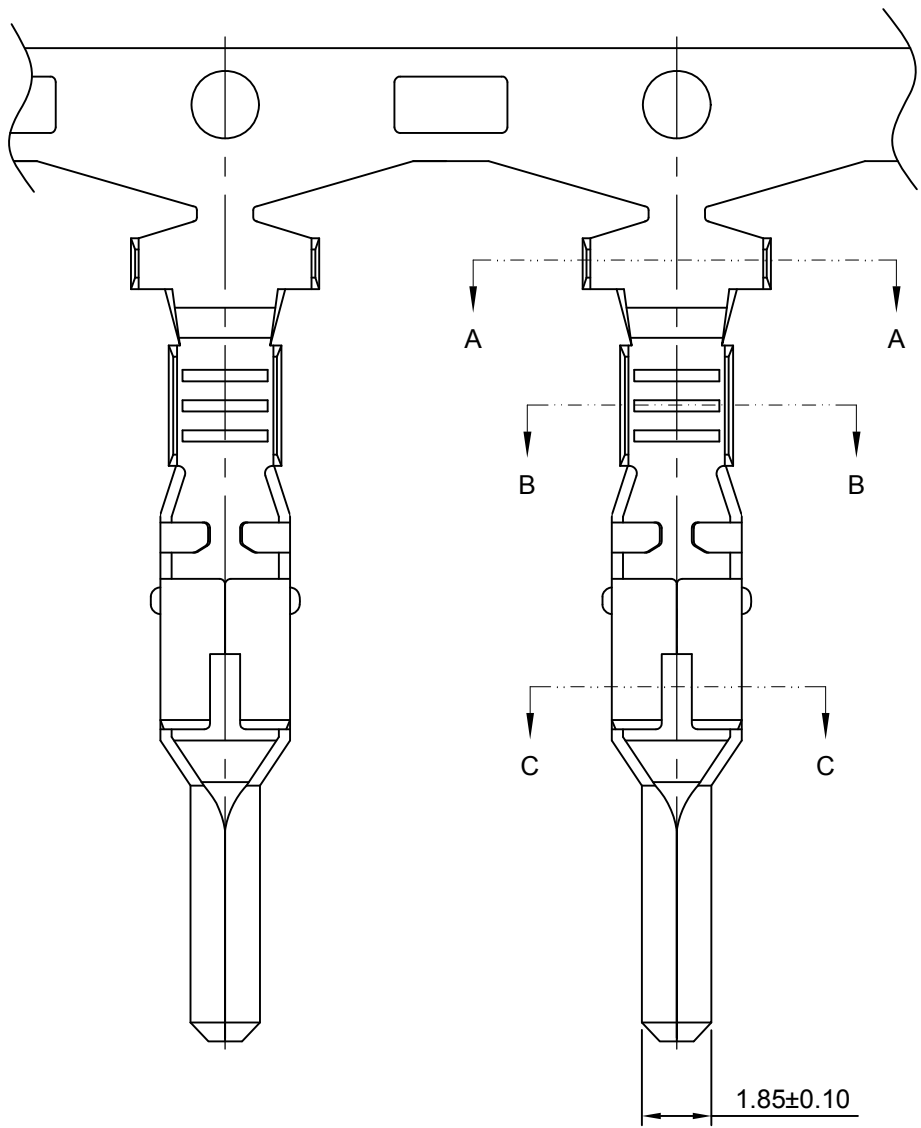

Ordering information & Specifications

Unit:mm

Part No	Wire Range	Insulation O.D.	Material	Finish	Qty/reel
HDGC6202MA-TP-L	AWG#20-#22	2.70mm(max)	Phosphor Bronze	Tin over Nickel	2,500 PCS
HDGC6202MA-GP-L	AWG#20-#22	2.70mm(max)	Phosphor Bronze	Gold over Nickel	2,500 PCS

Optional Gold plating available but MOQ requested

HDGC 深圳市华德共创科技有限公司
 SHENZHEN HUADE CO-CREATE TECHNOLOGY CO.,LTD
 TEL : 0755-27129737 FAX : 0755-29940187

-TOLERANCES- UNLESS OTHERWISE SPECIFIED 公差参数表					TITLE: 1.80mm Pitch 产品名称: Crimp Terminal			
X.X	±0.30	X.X°	±3°	APPD: 核准:	XIE			
X.XX	±0.30	X.XX°	±2°	CHECK: 校对:	WANG			
X.XXX	±0.10	X.XXX°	±1°	DRAW: 绘图:	WANG			
PART NO: 产品编号:					HDGC6202MA-T-L			
DATE					SCALE	UNIT	CODE NUMBER	
2012-12-20					5:1	mm	A008	

修订 REV	标记 MARK	修改摘要 REVISION DESCRIPTION	签名 SIGNATURE	日期 DATE
AO		NEW RELEASE	WANG	2018-01-12

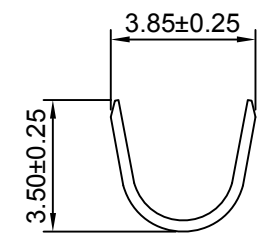
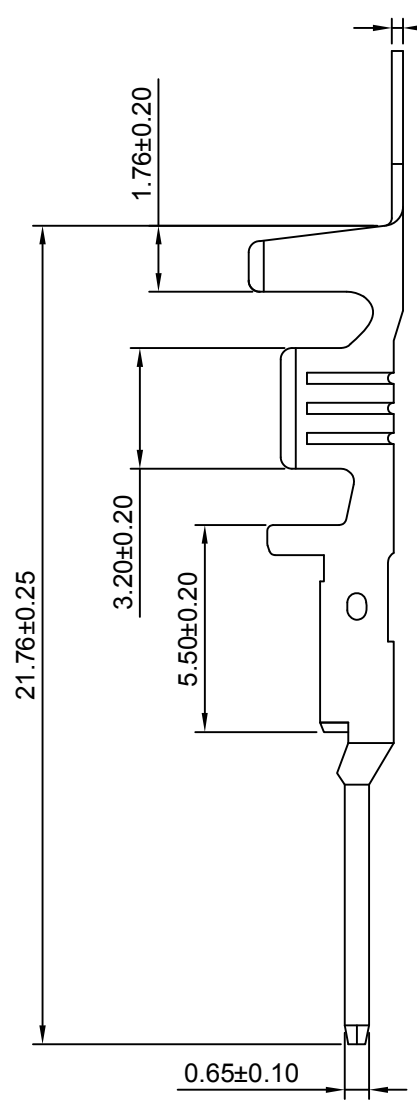
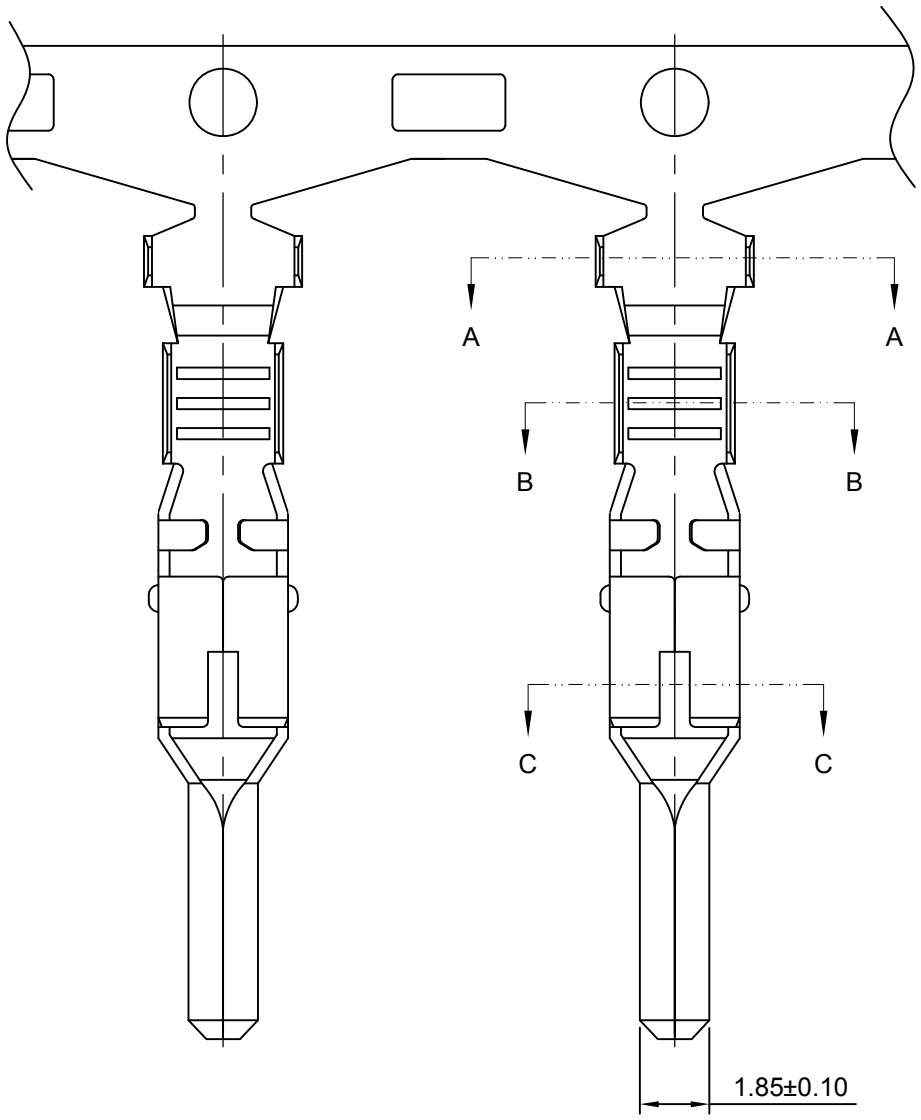

SEC:A-A

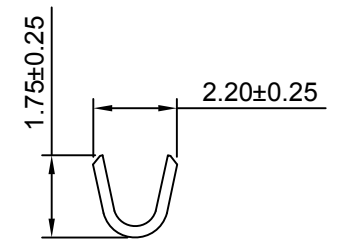

SEC:B-B

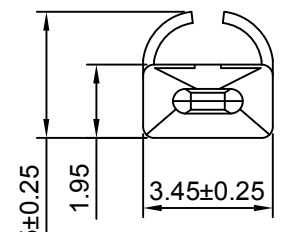

SEC:C-C

Ordering information & Specifications

Unit:mm

Part No	Wire Range	Insultion O.D.	Material	Finish	Qty/reel
HDGC6202MA-TP-LL	AWG#24	2.20mm(max)	Phosphor Bronze	Tin over Nickel	2,500 PCS
HDGC6202MA-GP-LL	AWG#24	2.20mm(max)	Phosphor Bronze	Gold over Nickel	2,500 PCS

Optional Gold plating available but MOQ requested

HDGC 深圳市华德共创科技有限公司
 SHENZHEN HUADE CO-CREATE TECHNOLOGY CO.,LTD
 TEL : 0755-27129737 FAX : 0755-29940187

-TOLERANCES- UNLESS OTHERWISE SPECIFIED 公差参数表						TITLE: 1.80mm Pitch 产品名称: Crimp Terminal			
X.X	±0.30	X.X°	±3°	APPD: 核准:	XIE	PART NO: 产品编号: HDGC6202MA-T-LL			
X.XX	±0.30	X.XX°	±2°	CHECK: 校对:	WANG	DATE	SCALE	UNIT	CODE NUMBER
X.XXX	±0.10	X.XXX°	±1°	DRAW: 绘图:	WANG	2018-01-12	5:1	mm	A008

修订 REV	标记 MARK	修改摘要 REVISION DESCRIPTION	签名 SIGNATURE	日期 DATE
AO		NEW RELEASE	WANG	2012-12-20

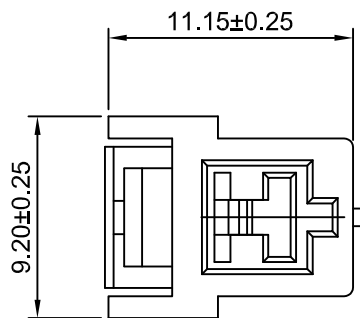
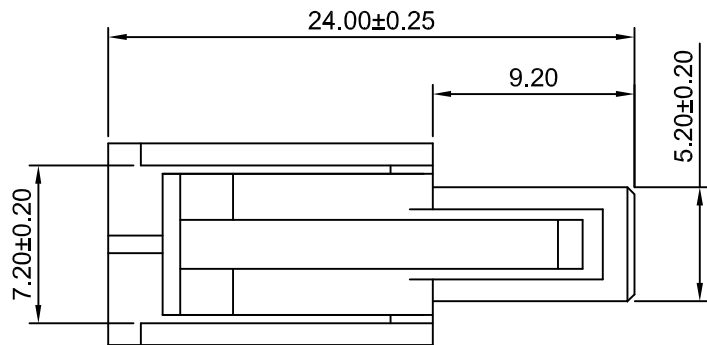
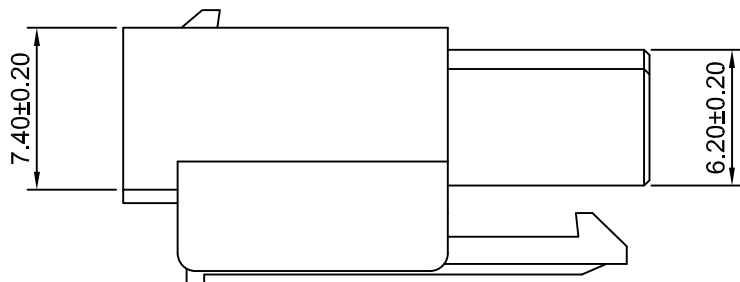

SPECIFICATIONS:

Current Rating: 15A AC,DC
Voltage Rating: 300V AC,DC
Temperature Range: -25°C~+85°C
Contact Resistance: 10mΩ Max
Insulation Resistance: 1000MΩ Min
Withstanding Voltage: 1500V AC/minute
Material: Nylon 66,UL94V-0(White)



深圳市华德共创科技有限公司

SHENZHEN HUADE CO-CREATE TECHNOLOGY CO.,LTD

TEL : 0755-27129737 FAX : 0755-29940187

-TOLERANCES- UNLESS OTHERWISE SPECIFIED 公差参数表				 		TITLE: 产品名称 : 1.80mm Width Housing			
X.X	±0.30	X.X°	±3°	APPD: 核准 :	XIE	PART NO: 产品编号 : HDGC6202HF-1P			
X.XX	±0.30	X.XX°	±2°	CHECK: 校对 :	WANG	DATE	SCALE	UNIT	CODE NUMBER
X.XXX	±0.10	X.XXX°	±1°	DRAW: 绘图 :	WANG	2012-12-20	3:1	mm	A008

修订 REV	标记 MARK	修改摘要 REVISION DESCRIPTION	签名 SIGNATURE	日期 DATE
AO		NEW RELEASE	WANG	2012-12-20

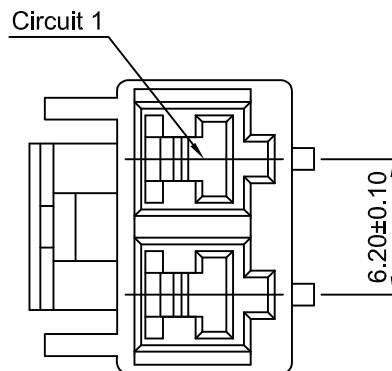
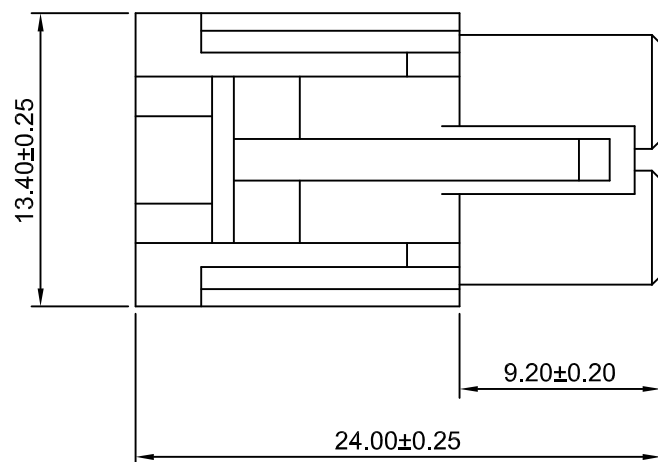
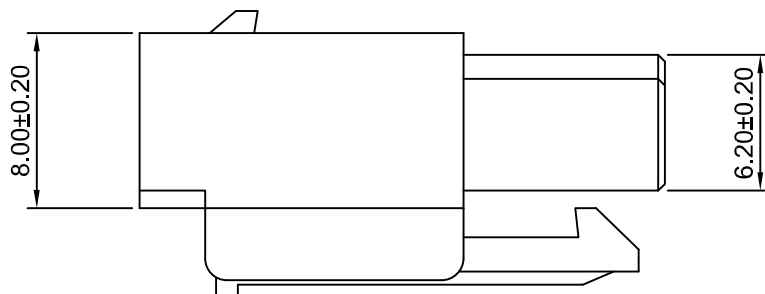

SPECIFICATIONS:
 Current Rating: 15A AC,DC
 Voltage Rating: 300V AC,DC
 Temperature Range: -25°C~+85°C
 Contact Resistance: 10mΩ Max
 Insulation Resistance: 1000MΩ Min
 Withstanding Voltage: 1500V AC/minute
 Material: Nylon 66,UL94V-0(White)



深圳市华德共创科技有限公司

SHENZHEN HUADE CO-CREATE TECHNOLOGY CO.,LTD



TEL : 0755-27129737 FAX : 0755-29940187

-TOLERANCES- UNLESS OTHERWISE SPECIFIED 公差参数表						TITLE: 产品名称 : 1.80mm Width Housing			
X.X	±0.30	X.X°	±3°	APPD: 核准 :	XIE	PART NO: 产品编号 : HDGC6202HF-2P			
X.XX	±0.30	X.XX°	±2°	CHECK: 校对 :	WANG	DATE	SCALE	UNIT	CODE NUMBER
X.XXX	±0.10	X.XXX°	±1°	DRAW: 绘图 :	WANG	2012-12-20	3:1	mm	A008

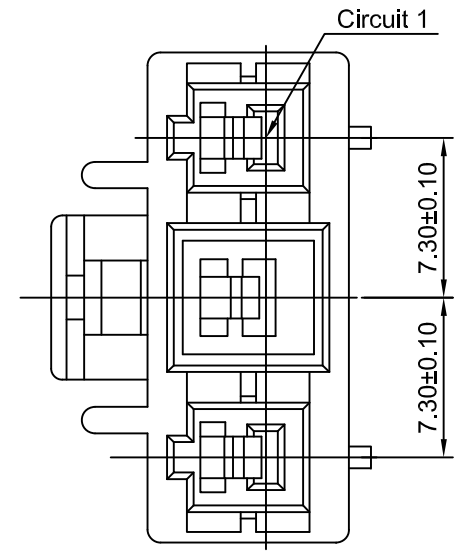
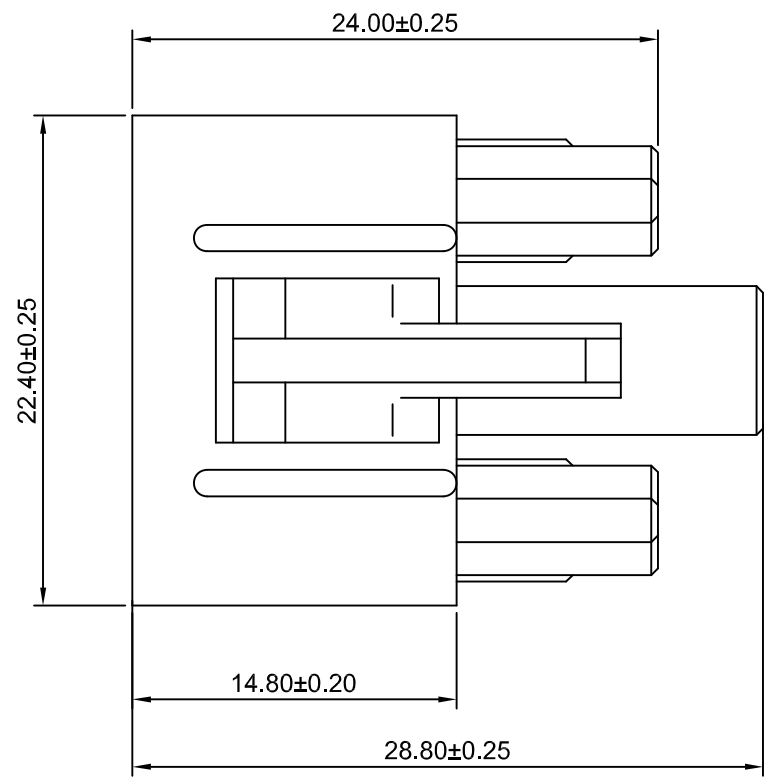
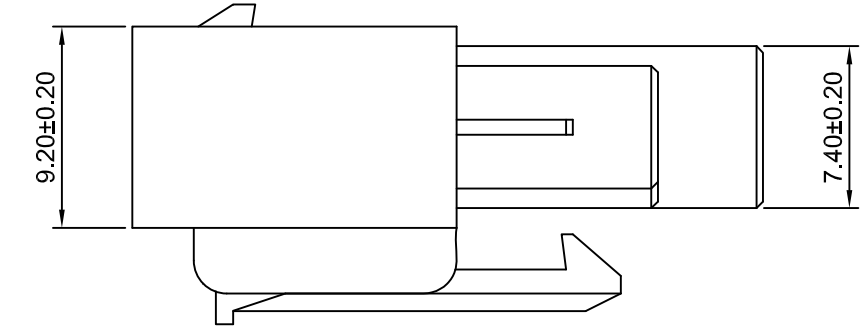
修订 REV	标记 MARK	修改摘要 REVISION DESCRIPTION	签名 SIGNATURE	日期 DATE
AO		NEW RELEASE	WANG	2012-12-20



SPECIFICATIONS:
 Current Rating: 15A AC,DC
 Voltage Rating: 300V AC,DC
 Temperature Range: -25°C~+85°C
 Contact Resistance: 10mΩ Max
 Insulation Resistance: 1000MΩ Min
 Withstanding Voltage: 1500V AC/minute
 Material: Nylon 66,UL94V-0(White)

 深圳市华德共创科技有限公司 SHENZHEN HUADE CO-CREATE TECHNOLOGY CO.,LTD TEL : 0755-27129737 FAX : 0755-29940187		TITLE: 1.80mm Width Housing 产品名称: 1.80mm Width Housing						
		PART NO: HDGC6202HF-3P 产品编号: HDGC6202HF-3P						
-TOLERANCES- UNLESS OTHERWISE SPECIFIED 公差参数表		 						
X.X	±0.30	X.X°	±3°	APPD: 核准: XIE	DATE			
X.XX	±0.30	X.XX°	±2°	CHECK: 校对: WANG	SCALE	UNIT	CODE NUMBER	
X.XXX	±0.10	X.XXX°	±1°	DRAW: 绘图: WANG	2012-12-20	3:1	mm	A008

修订 REV	标记 MARK	修改摘要 REVISION DESCRIPTION	签名 SIGNATURE	日期 DATE
AO		NEW RELEASE	WANG	2012-12-20

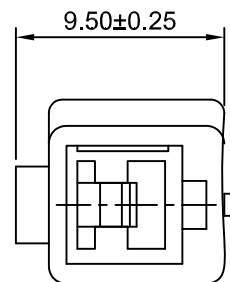
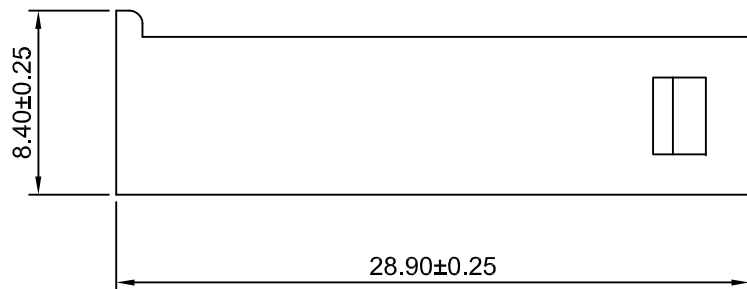
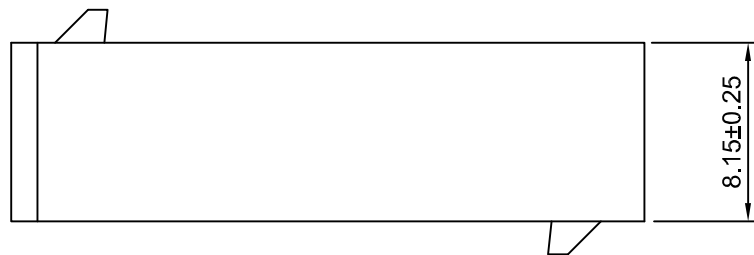

SPECIFICATIONS:

Current Rating: 15A AC,DC
Voltage Rating: 300V AC,DC
Temperature Range: -25°C~+85°C
Contact Resistance: 10mΩ Max
Insulation Resistance: 1000MΩ Min
Withstanding Voltage: 1500V AC/minute
Material: Nylon 66,UL94V-0(White)



深圳市华德共创科技有限公司

SHENZHEN HUADE CO-CREATE TECHNOLOGY CO.,LTD

TEL : 0755-27129737 FAX : 0755-29940187

-TOLERANCES- UNLESS OTHERWISE SPECIFIED 公差参数表				 		TITLE: 1.80mm Width Housing 产品名称 :			
X.X	±0.30	X.X°	±3°	APPD: 核准 :	XIE	PART NO: 产品编号 : HDGC6202HM-1P			
X.XX	±0.30	X.XX°	±2°	CHECK: 校对 :	WANG	DATE	SCALE	UNIT	CODE NUMBER
X.XXX	±0.10	X.XXX°	±1°	DRAW: 绘图 :	WANG	2012-12-20	3:1	mm	A008

修订 REV	标记 MARK	修改摘要 REVISION DESCRIPTION	签名 SIGNATURE	日期 DATE
AO		NEW RELEASE	WANG	2012-12-20

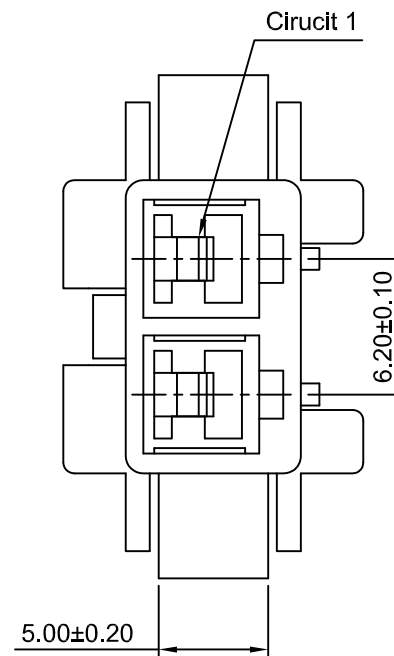
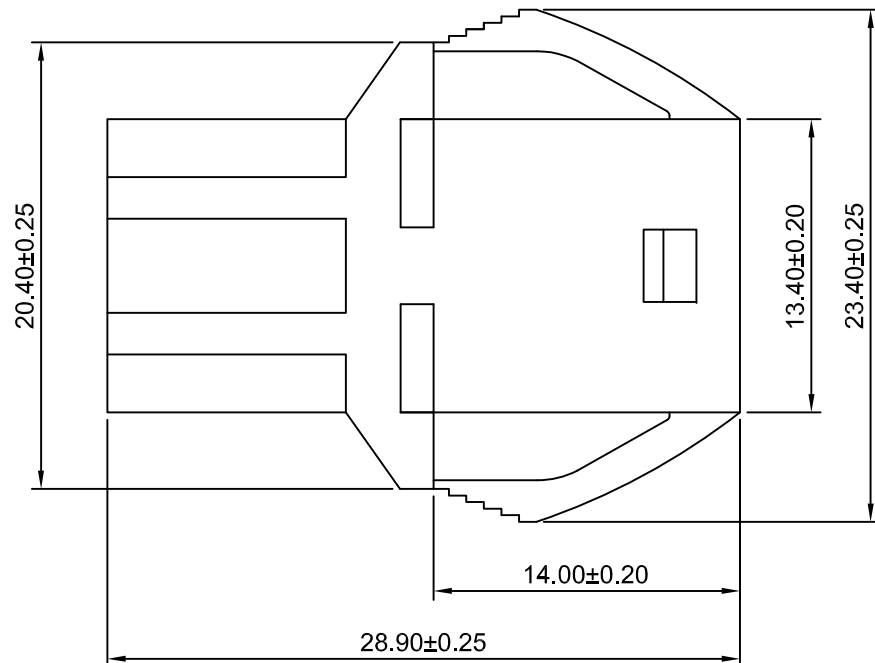
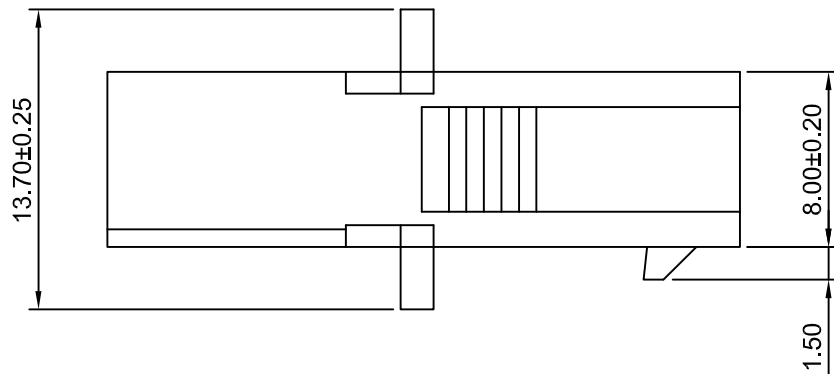

SPECIFICATIONS:

Current Rating: 15A AC,DC
Voltage Rating: 300V AC,DC
Temperature Range: -25°C~+85°C
Contact Resistance: 10mΩ Max
Insulation Resistance: 1000MΩ Min
Withstanding Voltage: 1500V AC/minute
Material: Nylon 66,UL94V-0(White)



深圳市华德共创科技有限公司

SHENZHEN HUADE CO-CREATE TECHNOLOGY CO.,LTD

TEL : 0755-27129737 FAX : 0755-29940187

-TOLERANCES- UNLESS OTHERWISE SPECIFIED 公差参数表				 		TITLE: 1.80mm Width Housing 产品名称 :			
X.X	±0.30	X.X°	±3°	APPD: 核准:	XIE	PART NO: 产品编号 : HDGC6202HM-2P			
X.XX	±0.30	X.XX°	±2°	CHECK: 校对:	WANG	DATE	SCALE	UNIT	CODE NUMBER
X.XXX	±0.10	X.XXX°	±1°	DRAW: 绘图:	WANG	2012-12-20	3:1	mm	A008

修订 REV	标记 MARK	修改摘要 REVISION DESCRIPTION	签名 SIGNATURE	日期 DATE
AO		NEW RELEASE	WANG	2012-12-20

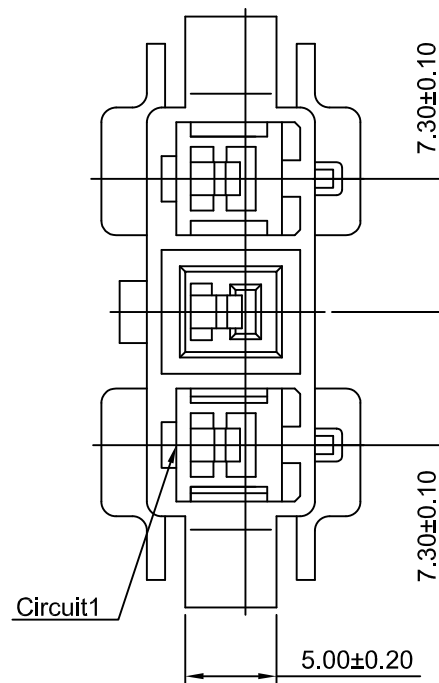
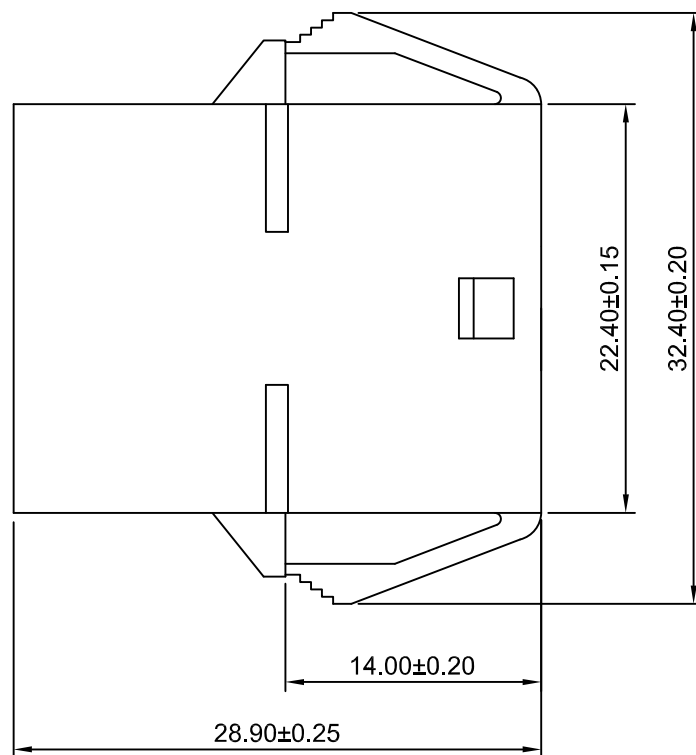
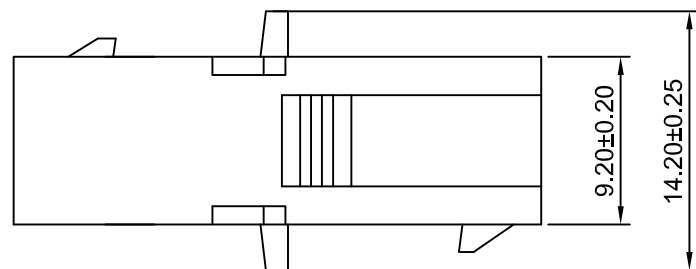

SPECIFICATIONS:
 Current Rating: 15A AC,DC
 Voltage Rating: 300V AC,DC
 Temperature Range: -25°C~+85°C
 Contact Resistance: 10mΩ Max
 Insulation Resistance: 1000MΩ Min
 Withstanding Voltage: 1500V AC/minute
 Material: Nylon 66,UL94V-0(White)

HDGC 深圳市华德共创科技有限公司
 SHENZHEN HUADE CO-CREATE TECHNOLOGY CO.,LTD
 TEL : 0755-27129737 FAX : 0755-29940187

-TOLERANCES- UNLESS OTHERWISE SPECIFIED 公差参数表						TITLE: 1.80mm Width Housing 产品名称:			
X.X	±0.30	X.X°	±3°	APPD: 核准:	XIE	PART NO: 产品编号: HDGC6202HM-3P			
X.XX	±0.30	X.XX°	±2°	CHECK: 校对:	WANG	DATE	SCALE	UNIT	CODE NUMBER
X.XXX	±0.10	X.XXX°	±1°	DRAW: 绘图:	WANG	2012-12-20	2.5:1	mm	A008

修订 REV	标记 MARK	修改摘要 REVISION DESCRIPTION	签名 SIGNATURE	日期 DATE
AO		NEW RELEASE	WANG	2012-12-20

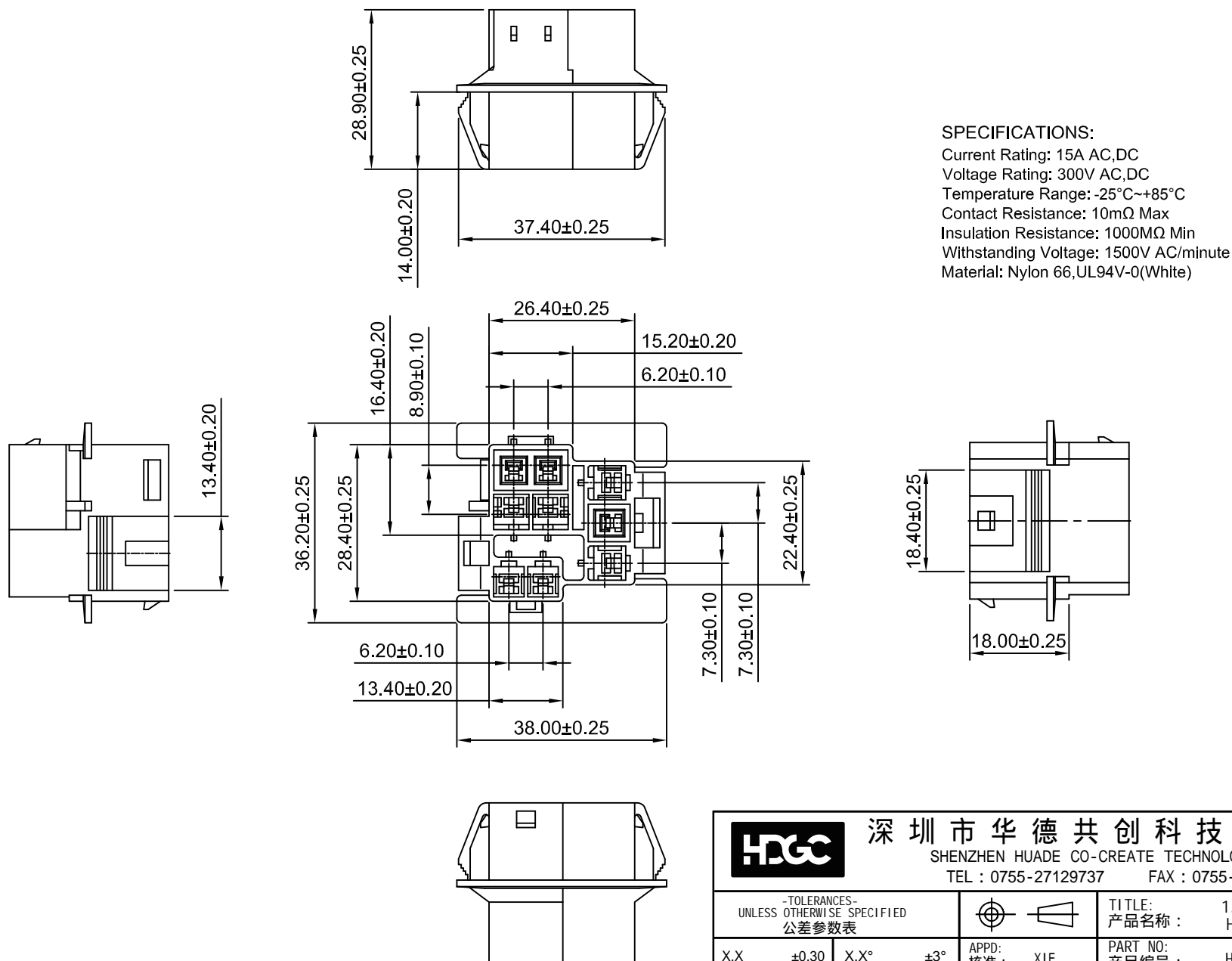

HDGC 深圳市华德共创科技有限公司
 SHENZHEN HUADE CO-CREATE TECHNOLOGY CO.,LTD
 TEL : 0755-27129737 FAX : 0755-29940187

-TOLERANCES- UNLESS OTHERWISE SPECIFIED 公差参数表						TITLE: 1.80mm Width 产品名称: Housing			
X.X	±0.30	X.X°	±3°	APPD: 核准:	XIE	PART NO: 产品编号: HDGC6202HM-9P			
X.XX	±0.30	X.XX°	±2°	CHECK: 校对:	WANG	DATE	SCALE	UNIT	CODE NUMBER
X.XXX	±0.10	X.XXX°	±1°	DRAW: 绘图:	WANG	2012-12-20	1:1	mm	A008

修订 REV	标记 MARK	修改摘要 REVISION DESCRIPTION	签名 SIGNATURE	日期 DATE
AO		NEW RELEASE	WANG	2012-12-20

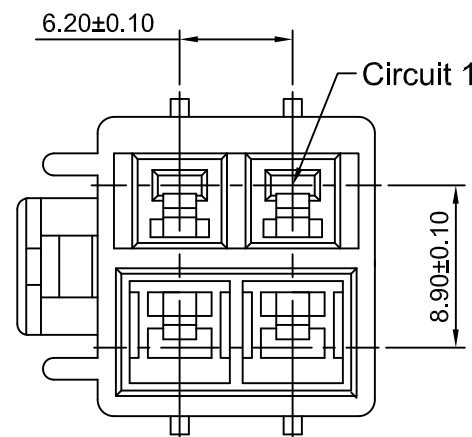
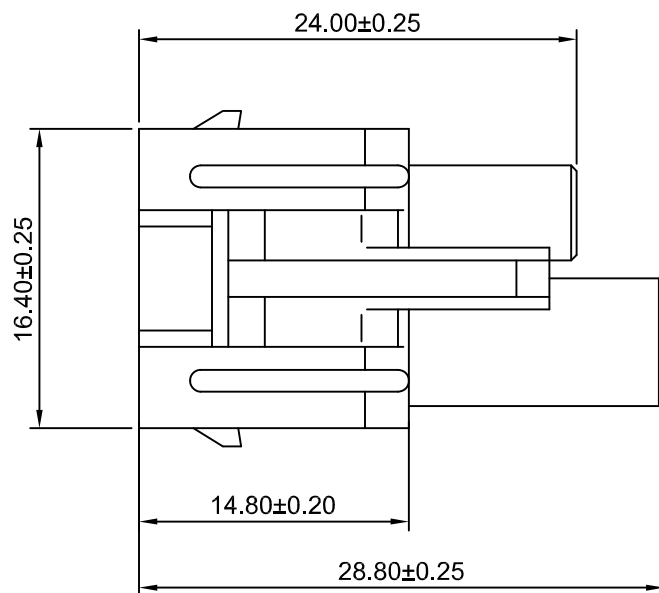
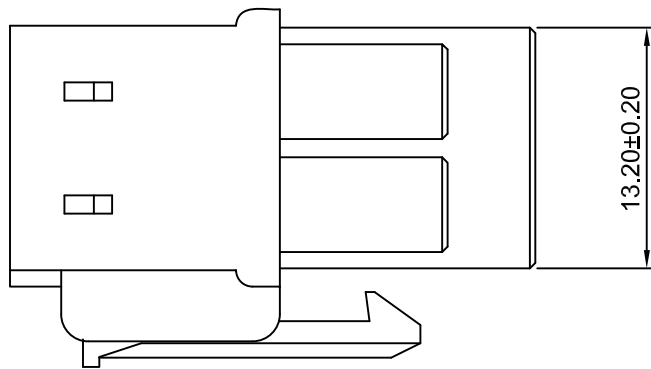

SPECIFICATIONS:

Current Rating: 15A AC,DC
Voltage Rating: 300V AC,DC
Temperature Range: -25°C~+85°C
Contact Resistance: 10mΩ Max
Insulation Resistance: 1000MΩ Min
Withstanding Voltage: 1500V AC/minute
Material: Nylon 66,UL94V-0(White)



深圳市华德共创科技有限公司

SHENZHEN HUADE CO-CREATE TECHNOLOGY CO.,LTD

TEL : 0755-27129737 FAX : 0755-29940187

-TOLERANCES- UNLESS OTHERWISE SPECIFIED 公差参数表						TITLE: 产品名称 : 1.80mm Width Housing			
X.X	±0.30	X.X°	±3°	APPD: 核准 :	XIE	PART NO: 产品编号 : HDGC6202HF-2x2P			
X.XX	±0.30	X.XX°	±2°	CHECK: 校对 :	WANG	DATE	SCALE	UNIT	CODE NUMBER
X.XXX	±0.10	X.XXX°	±1°	DRAW: 绘图 :	WANG	2012-12-20	2.5:1	mm	A008

修订 REV	标记 MARK	修改摘要 REVISION DESCRIPTION	签名 SIGNATURE	日期 DATE
AO		NEW RELEASE	WANG	2012-12-20

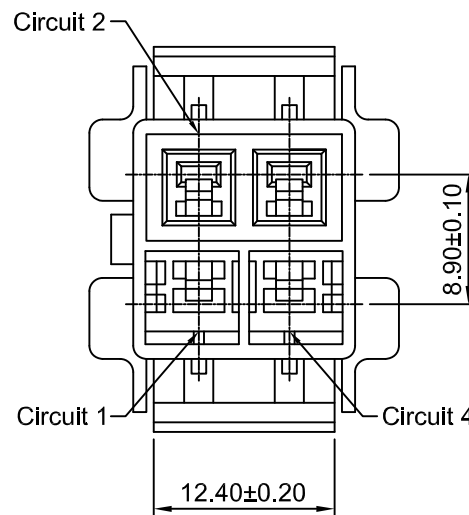
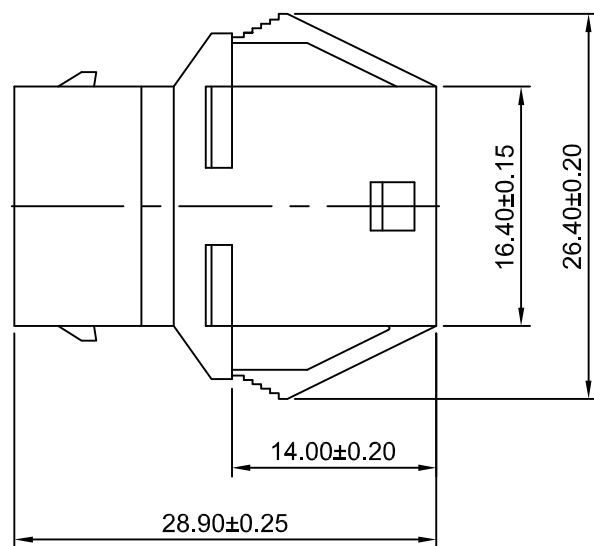
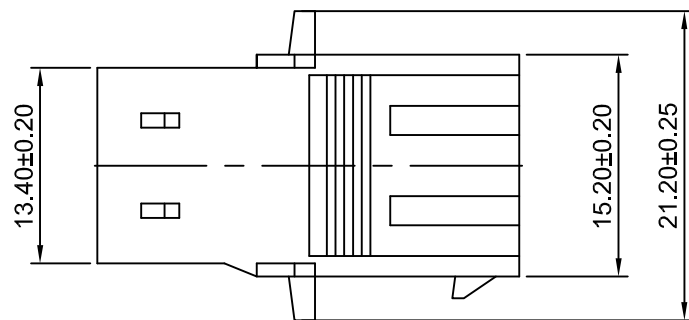

SPECIFICATIONS:

Current Rating: 15A AC,DC
Voltage Rating: 300V AC,DC
Temperature Range: -25°C~+85°C
Contact Resistance: 10mΩ Max
Insulation Resistance: 1000MΩ Min
Withstanding Voltage: 1500V AC/minute
Material: Nylon 66,UL94V-0(White)

HDGC 深圳市华德共创科技有限公司
SHENZHEN HUADE CO-CREATE TECHNOLOGY CO.,LTD
TEL : 0755-27129737 FAX : 0755-29940187

-TOLERANCES- UNLESS OTHERWISE SPECIFIED 公差参数表						TITLE: 1.80mm Width Housing 产品名称: 1.80mm Width Housing			
X.X	±0.30	X.X°	±3°	APPD: 核准:	XIE	PART NO: 产品编号: HDGC6202HM-2x2P			
X.XX	±0.30	X.XX°	±2°	CHECK: 校对:	WANG	DATE	SCALE	UNIT	CODE NUMBER
X.XXX	±0.10	X.XXX°	±1°	DRAW: 绘图:	WANG	2012-12-20	2:1	mm	A008

修订 REV	标记 MARK	修改摘要 REVISION DESCRIPTION	签名 SIGNATURE	日期 DATE
AO		NEW RELEASE	WANG	2012-12-20

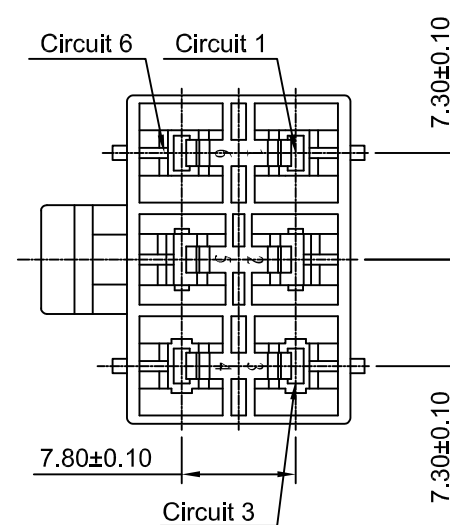
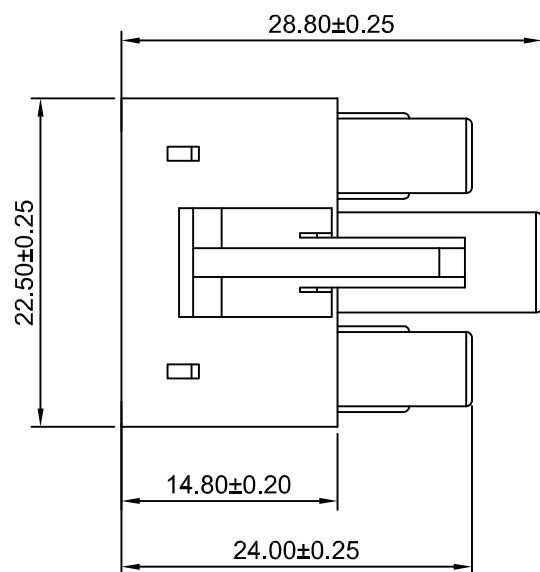
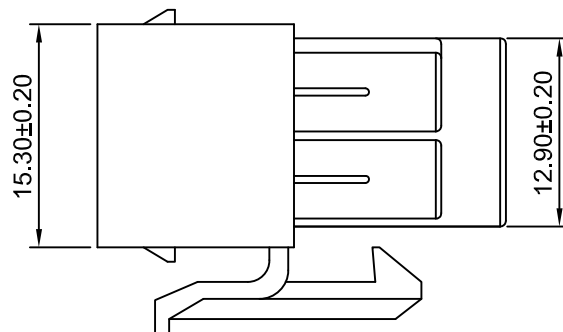

SPECIFICATIONS:

Current Rating: 15A AC,DC
Voltage Rating: 300V AC,DC
Temperature Range: -25°C~+85°C
Contact Resistance: 10mΩ Max
Insulation Resistance: 1000MΩ Min
Withstanding Voltage: 1500V AC/minute
Material: Nylon 66,UL94V-0(White)



深圳市华德共创科技有限公司

SHENZHEN HUADE CO-CREATE TECHNOLOGY CO.,LTD

TEL : 0755-27129737 FAX : 0755-29940187

-TOLERANCES- UNLESS OTHERWISE SPECIFIED 公差参数表				 		TITLE: 1.80mm Width Housing 产品名称 :			
X.X	±0.30	X.X°	±3°	APPD: 核准 :	XIE	PART NO: 产品编号 : HDGC6202HF-2x3P			
X.XX	±0.30	X.XX°	±2°	CHECK: 校对 :	WANG	DATE	SCALE	UNIT	CODE NUMBER
X.XXX	±0.10	X.XXX°	±1°	DRAW: 绘图 :	WANG	2012-12-20	2:1	mm	A008

修订 REV	标记 MARK	修改摘要 REVISION DESCRIPTION	签名 SIGNATURE	日期 DATE
AO		NEW RELEASE	WANG	2012-12-20

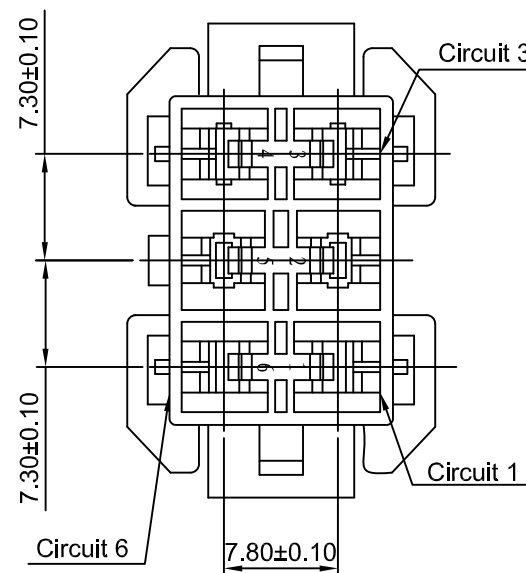
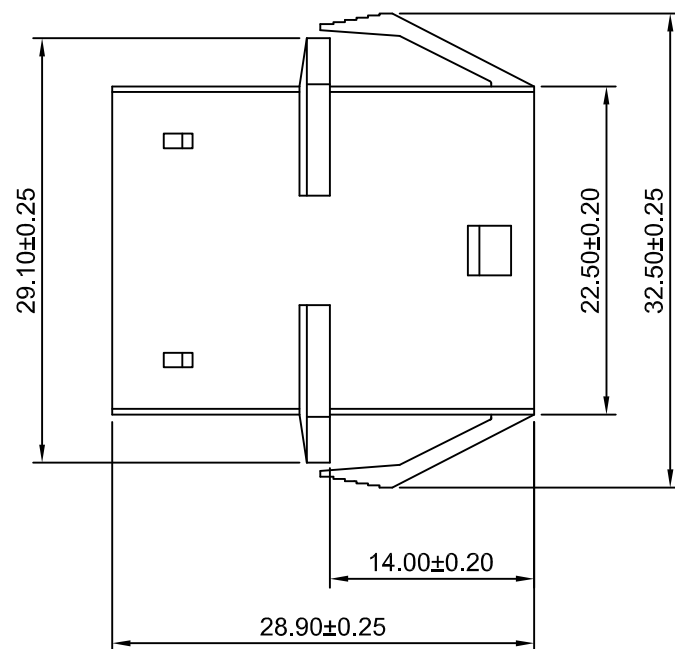
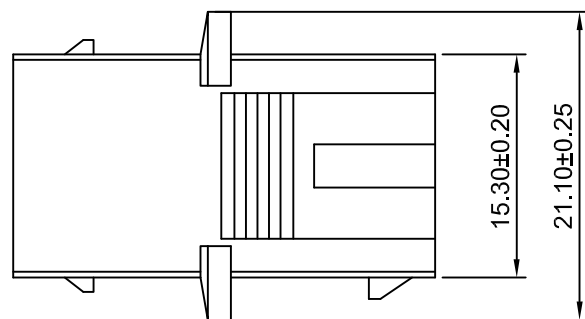

SPECIFICATIONS:

Current Rating: 15A AC,DC
Voltage Rating: 300V AC,DC
Temperature Range: -25°C~+85°C
Contact Resistance: 10mΩ Max
Insulation Resistance: 1000MΩ Min
Withstanding Voltage: 1500V AC/minute
Material: Nylon 66,UL94V-0(White)



深圳市华德共创科技有限公司

SHENZHEN HUADE CO-CREATE TECHNOLOGY CO.,LTD

TEL : 0755-27129737 FAX : 0755-29940187

-TOLERANCES- UNLESS OTHERWISE SPECIFIED 公差参数表						TITLE: 1.80mm Width Housing 产品名称 :			
X.X	±0.30	X.X°	±3°	APPD: 核准 :	XIE	PART NO: 产品编号 : HDGC6202HM-2x3P			
X.XX	±0.30	X.XX°	±2°	CHECK: 校对 :	WANG	DATE	SCALE	UNIT	CODE NUMBER
X.XXX	±0.10	X.XXX°	±1°	DRAW: 绘图 :	WANG	2012-12-20	2:1	mm	A008

修订 REV	标记 MARK	修改摘要 REVISION DESCRIPTION	签名 SIGNATURE	日期 DATE
AO		NEW RELEASE	WANG	2012-12-20

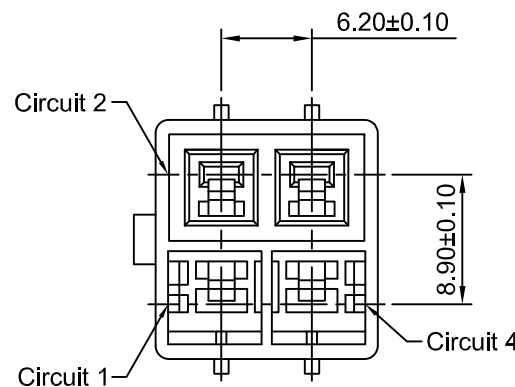
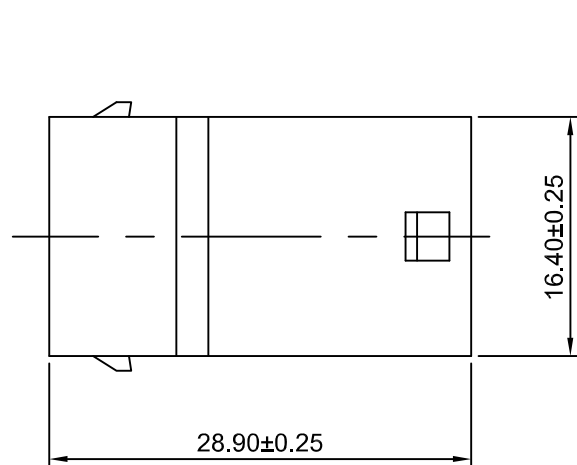
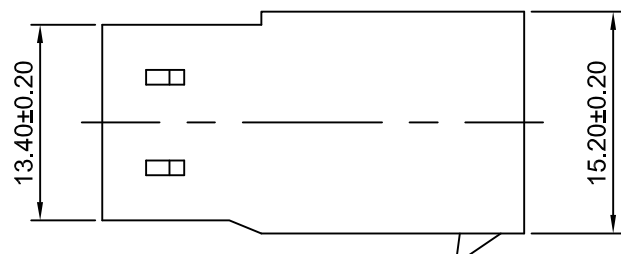

SPECIFICATIONS:

Current Rating: 15A AC,DC
Voltage Rating: 300V AC,DC
Temperature Range: -25°C~+85°C
Contact Resistance: 10mΩ Max
Insulation Resistance: 1000MΩ Min
Withstanding Voltage: 1500V AC/minute
Material: Nylon 66,UL94V-0(White)



深圳市华德共创科技有限公司

SHENZHEN HUADE CO-CREATE TECHNOLOGY CO.,LTD

TEL : 0755-27129737 FAX : 0755-29940187

-TOLERANCES- UNLESS OTHERWISE SPECIFIED 公差参数表						TITLE: 1.80mm Width 产品名称: Housing			
X.X	±0.30	X.X°	±3°	APPD: 核准:	XIE	PART NO: 产品编号: HDGC6202HMA-2x2P			
X.XX	±0.30	X.XX°	±2°	CHECK: 校对:	WANG	DATE	SCALE	UNIT	CODE NUMBER
X.XXX	±0.10	X.XXX°	±1°	DRAW: 绘图:	WANG	2012-12-20	2:1	mm	A008

修订 REV	标记 MARK	修改摘要 REVISION DESCRIPTION	签名 SIGNATURE	日期 DATE
AO		NEW RELEASE	WANG	2012-12-20

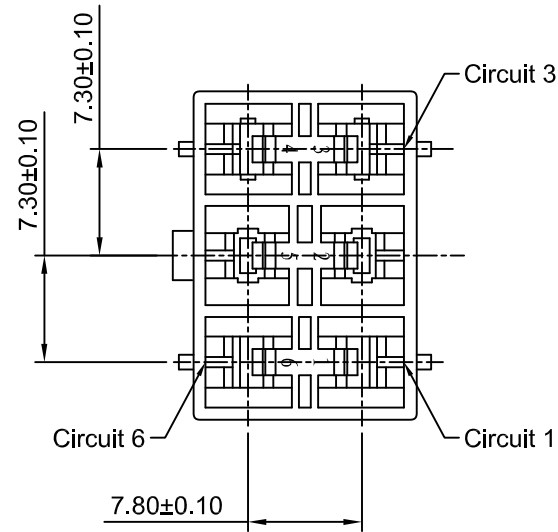
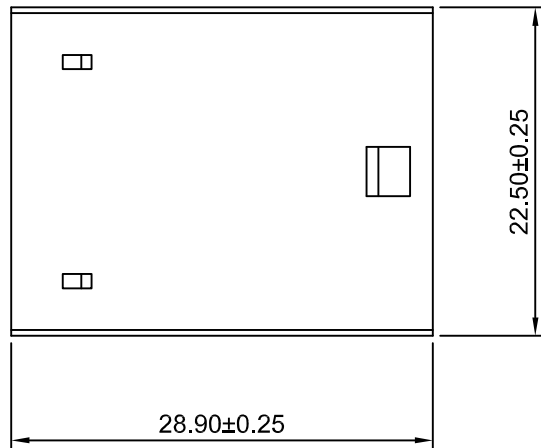
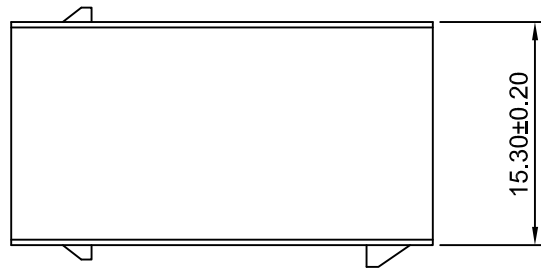

SPECIFICATIONS:
 Current Rating: 15A AC,DC
 Voltage Rating: 300V AC,DC
 Temperature Range: -25°C~+85°C
 Contact Resistance: 10mΩ Max
 Insulation Resistance: 1000MΩ Min
 Withstanding Voltage: 1500V AC/minute
 Material: Nylon 66,UL94V-0(White)



深圳市华德共创科技有限公司

SHENZHEN HUADE CO-CREATE TECHNOLOGY CO.,LTD

TEL : 0755-27129737 FAX : 0755-29940187

-TOLERANCES- UNLESS OTHERWISE SPECIFIED 公差参数表				 		TITLE: 产品名称 : 1.80mm Width Housing			
X.X	±0.30	X.X°	±3°	APPD: 核准 :	XIE	PART NO: 产品编号 : HDGC6202HMA-2x3P			
X.XX	±0.30	X.XX°	±2°	CHECK: 校对 :	WANG	DATE	SCALE	UNIT	CODE NUMBER
X.XXX	±0.10	X.XXX°	±1°	DRAW: 绘图 :	WANG	2012-12-20	2:1	mm	A008

修订 REV	标记 MARK	修改摘要 REVISION DESCRIPTION	签名 SIGNATURE	日期 DATE
AO		NEW RELEASE	WANG	2012-12-20

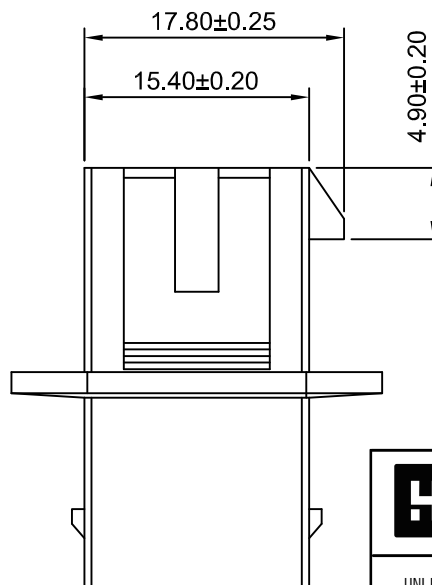
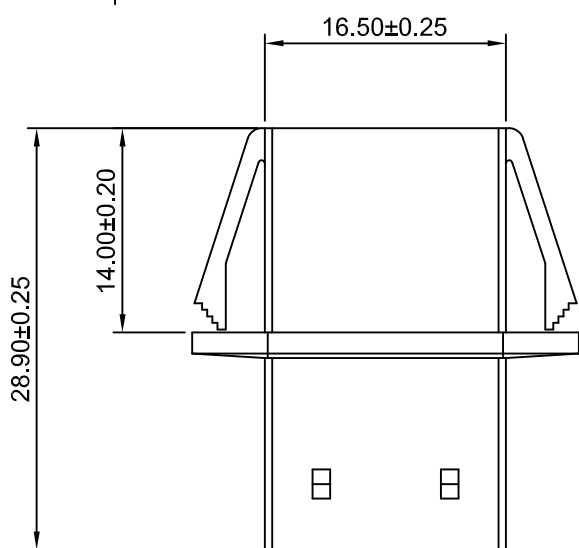
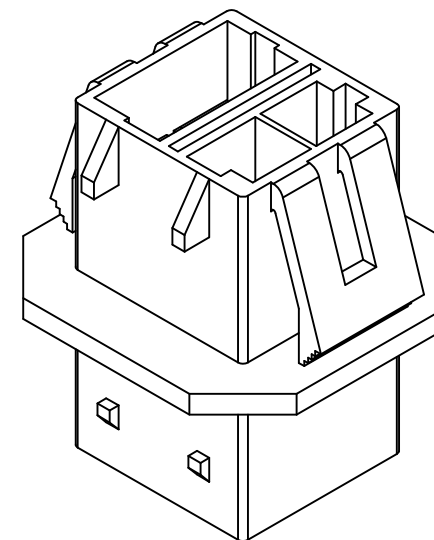
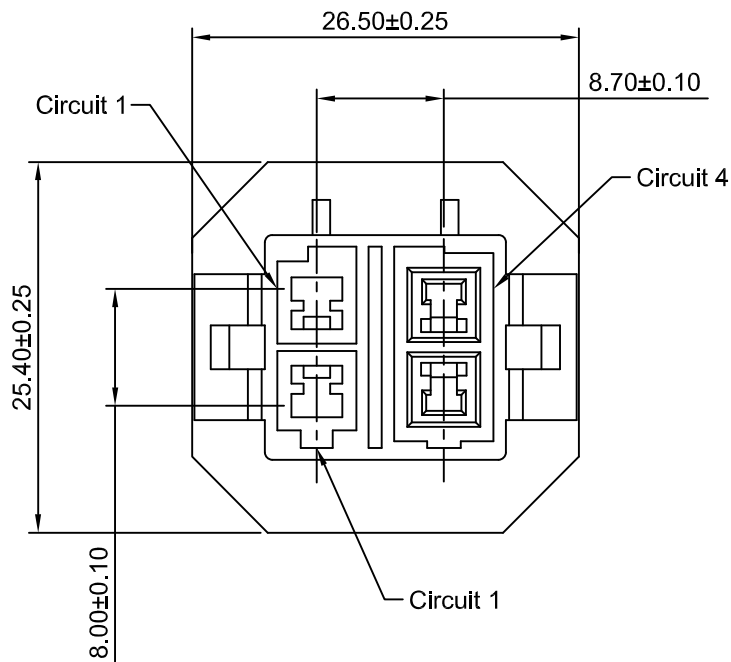

SPECIFICATIONS:

Current Rating: 2A AC,DC
Voltage Rating: 250V AC,DC
Temperature Range: -25°C~+85°C
Contact Resistance: 20mΩ Max.
Insulation Resistance: 1000MΩ Min.
Withstanding Voltage: 1000V AC/minute
Material:Nylon 66,UL94V-0(White)

 深圳市华德共创科技有限公司 SHENZHEN HUADE CO-CREATE TECHNOLOGY CO.,LTD TEL : 0755-27129737 FAX : 0755-29940187				TITLE: 8.00/8.50/8.70mm 产品名称: Pitch Housing					
-TOLERANCES- UNLESS OTHERWISE SPECIFIED 公差参数表				 		PART NO: 产品编号: HDGC6202HMB-2x2P			
X.X	±0.30	X.X°	±3°	APPD: 核准:	XIE	DATE	SCALE	UNIT	CODE NUMBER
X.XX	±0.30	X.XX°	±2°	CHECK: 校对:	WANG	2012-12-20	2:1	mm	A008
X.XXX	±0.10	X.XXX°	±1°	DRAW: 绘图:	WANG				

修订 REV	标记 MARK	修改摘要 REVISION DESCRIPTION	签名 SIGNATURE	日期 DATE
AO		NEW RELEASE	WANG	2012-12-20

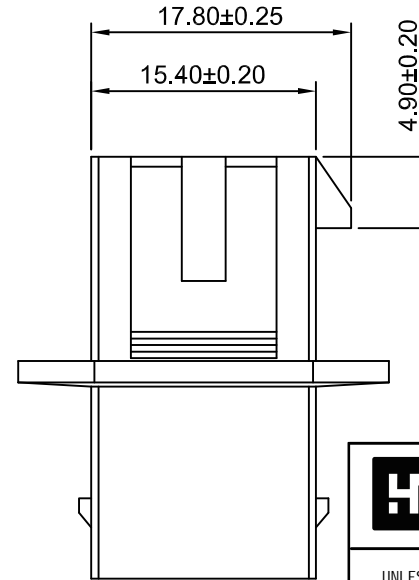
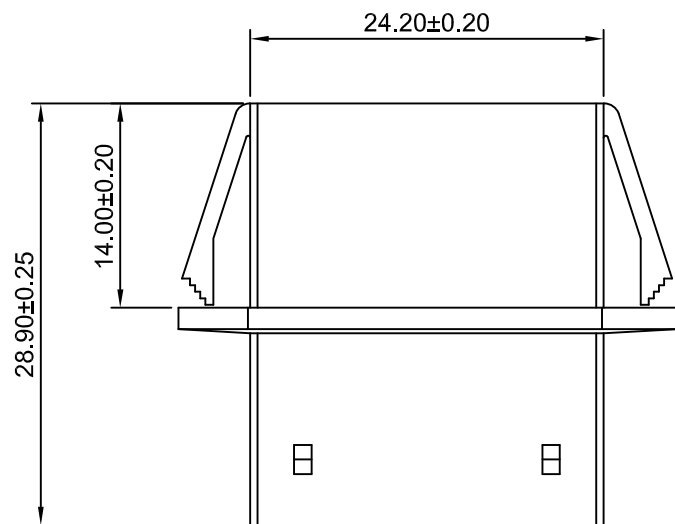
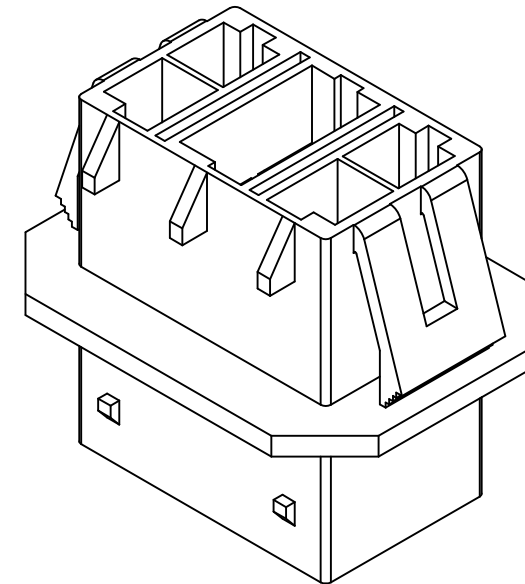
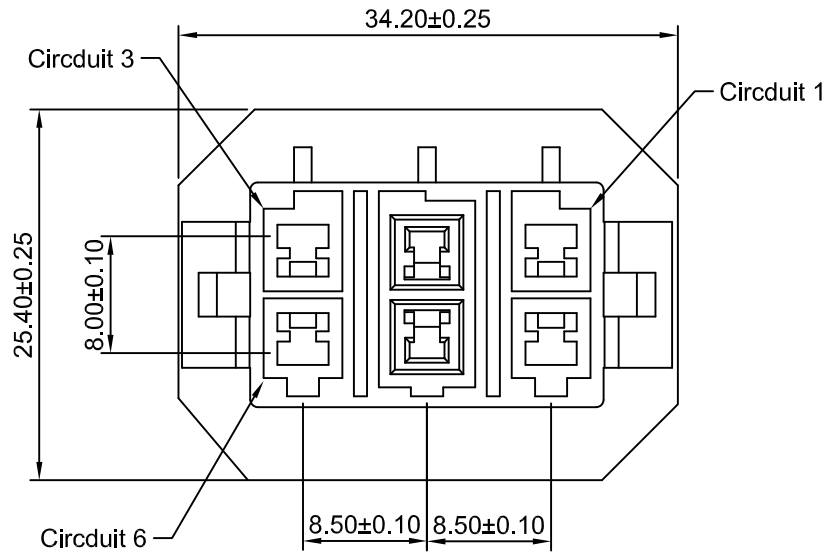

SPECIFICATIONS:

Current Rating: 2A AC,DC
Voltage Rating: 250V AC,DC
Temperature Range: -25°C~+85°C
Contact Resistance: 20mΩ Max.
Insulation Resistance: 1000MΩ Min.
Withstanding Voltage: 1000V AC/minute
Material: Nylon 66, UL94V-0(White)



深圳市华德共创科技有限公司

SHENZHEN HUADE CO-CREATE TECHNOLOGY CO., LTD

TEL : 0755-27129737 FAX : 0755-29940187

-TOLERANCES- UNLESS OTHERWISE SPECIFIED 公差参数表						TITLE: 8.00/8.50/8.70mm 产品名称: Pitch Housing			
X.X	±0.30	X.X°	±3°	APPD: 核准:	XIE	PART NO: 产品编号: HDGC6202HMB-2x3P			
X.XX	±0.30	X.XX°	±2°	CHECK: 校对:	WANG	DATE	SCALE	UNIT	CODE NUMBER
X.XXX	±0.10	X.XXX°	±1°	DRAW: 绘图:	WANG	2012-12-20	2:1	mm	A008

修订 REV	标记 MARK	修改摘要 REVISION DESCRIPTION	签名 SIGNATURE	日期 DATE
AO		NEW RELEASE	WANG	2012-12-20

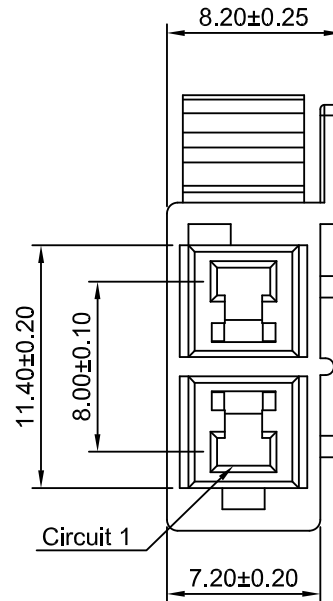
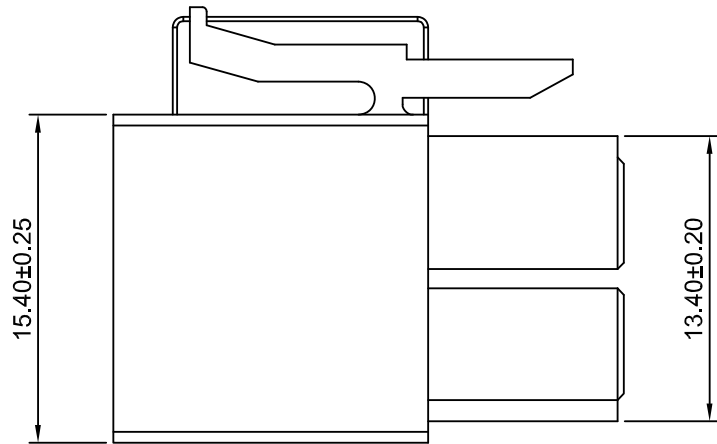
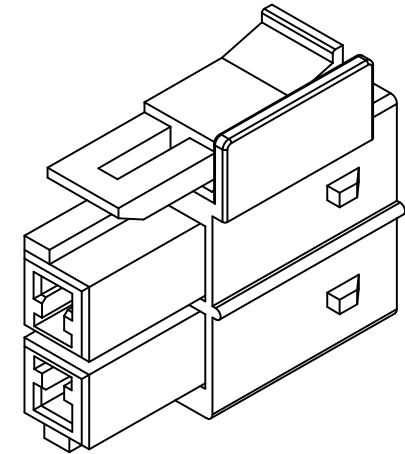
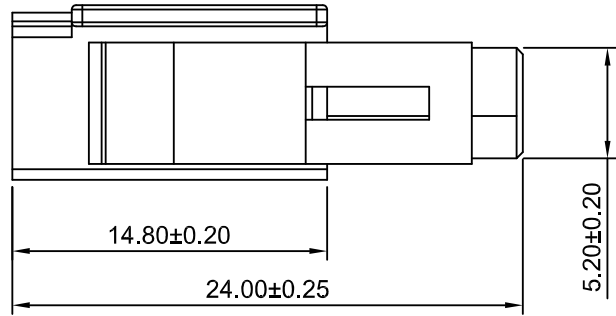

SPECIFICATIONS:

Current Rating: 2A AC,DC
Voltage Rating: 250V AC,DC
Temperature Range: -25°C~+85°C
Contact Resistance: 20mΩ Max.
Insulation Resistance: 1000MΩ Min.
Withstanding Voltage: 1000V AC/minute
Material:Nylon 66,UL94V-0(White)



深圳市华德共创科技有限公司

SHENZHEN HUADE CO-CREATE TECHNOLOGY CO.,LTD

TEL : 0755-27129737 FAX : 0755-29940187

-TOLERANCES- UNLESS OTHERWISE SPECIFIED 公差参数表						TITLE: 8.00/8.50/8.70mm 产品名称: Pitch Housing			
X.X	±0.30	X.X°	±3°	APPD: 核准:	XIE	PART NO: 产品编号: HDGC6202HFB-2P-L			
X.XX	±0.30	X.XX°	±2°	CHECK: 校对:	WANG	DATE	SCALE	UNIT	CODE NUMBER
X.XXX	±0.10	X.XXX°	±1°	DRAW: 绘图:	WANG	2012-12-20	3:1	mm	A008

修订 REV	标记 MARK	修改摘要 REVISION DESCRIPTION	签名 SIGNATURE	日期 DATE
AO		NEW RELEASE	WANG	2012-12-20

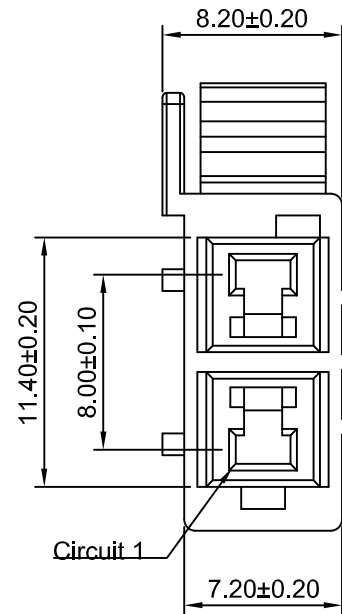
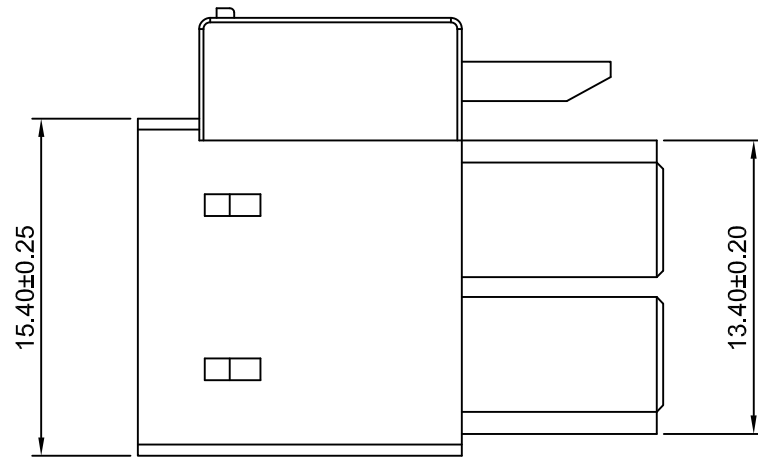
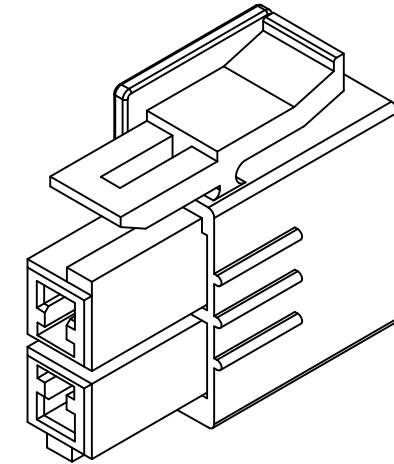
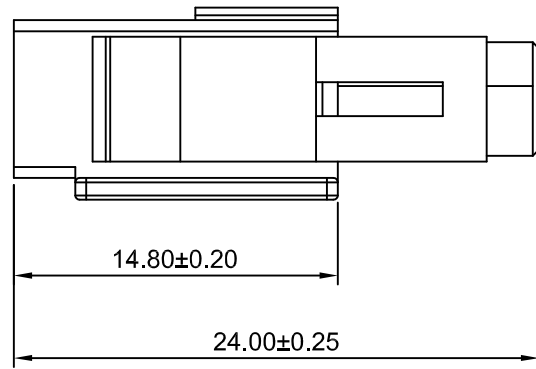

SPECIFICATIONS:
 Current Rating: 2A AC,DC
 Voltage Rating: 250V AC,DC
 Temperature Range: -25°C~+85°C
 Contact Resistance: 20mΩ Max.
 Insulation Resistance: 1000MΩ Min.
 Withstanding Voltage: 1000V AC/minute
 Material:Nylon 66,UL94V-0(White)



深圳市华德共创科技有限公司

SHENZHEN HUADE CO-CREATE TECHNOLOGY CO.,LTD

TEL : 0755-27129737 FAX : 0755-29940187

-TOLERANCES- UNLESS OTHERWISE SPECIFIED 公差参数表						TITLE: 8.00/8.50/8.70mm 产品名称: Pi tch Housi ng			
X.X	±0.30	X.X°	±3°	APPD: 核准:	XIE	PART NO: 产品编号: HDGC6202HFB-2P-R			
X.XX	±0.30	X.XX°	±2°	CHECK: 校对:	WANG	DATE	SCALE	UNIT	CODE NUMBER
X.XXX	±0.10	X.XXX°	±1°	DRAW: 绘图:	WANG	2012-12-20	3:1	mm	A008

修订 REV	标记 MARK	修改摘要 REVISION DESCRIPTION	签名 SIGNATURE	日期 DATE
AO		NEW RELEASE	WANG	2012-12-20

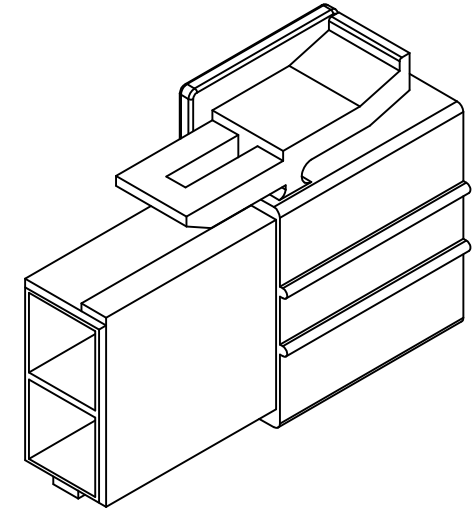
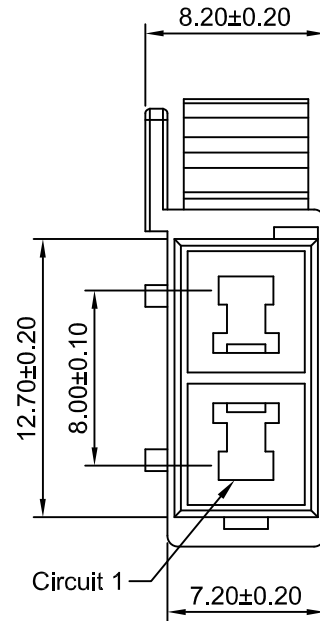
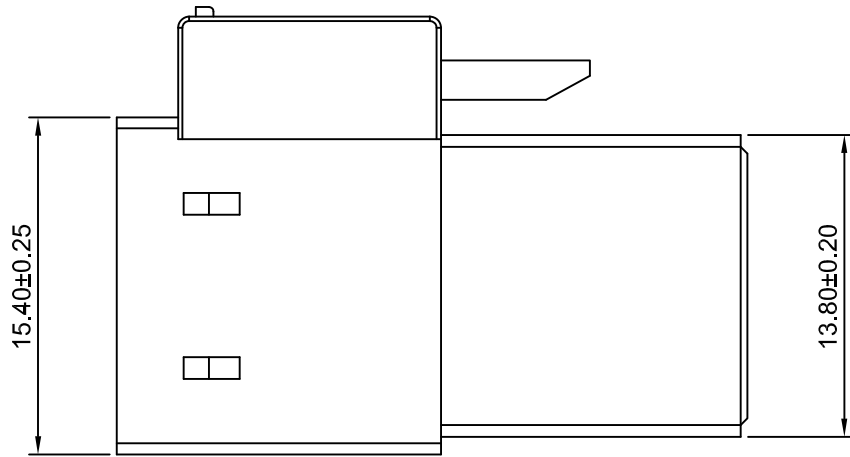
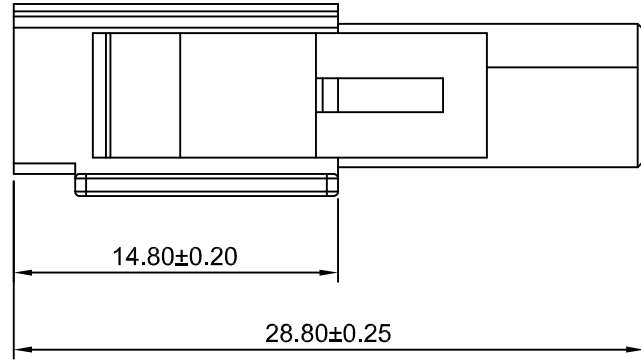

SPECIFICATIONS:

Current Rating: 2A AC,DC
Voltage Rating: 250V AC,DC
Temperature Range: -25°C~+85°C
Contact Resistance: 20mΩ Max.
Insulation Resistance: 1000MΩ Min.
Withstanding Voltage: 1000V AC/minute
Material:Nylon 66,UL94V-0(White)



深圳市华德共创科技有限公司

SHENZHEN HUADE CO-CREATE TECHNOLOGY CO.,LTD

TEL : 0755-27129737 FAX : 0755-29940187

-TOLERANCES- UNLESS OTHERWISE SPECIFIED 公差参数表						TITLE: 8.00/8.50/8.70mm 产品名称: Pitch Housing			
X.X	±0.30	X.X°	±3°	APPD: 核准:	XIE	PART NO: 产品编号: HDGC6202HFB-2P-RH			
X.XX	±0.30	X.XX°	±2°	CHECK: 校对:	WANG	DATE	SCALE	UNIT	CODE NUMBER
X.XXX	±0.10	X.XXX°	±1°	DRAW: 绘图:	WANG	2012-12-20	3:1	mm	A008

修订 REV	标记 MARK	修改摘要 REVISION DESCRIPTION	签名 SIGNATURE	日期 DATE
AO		NEW RELEASE	WANG	2012-12-20

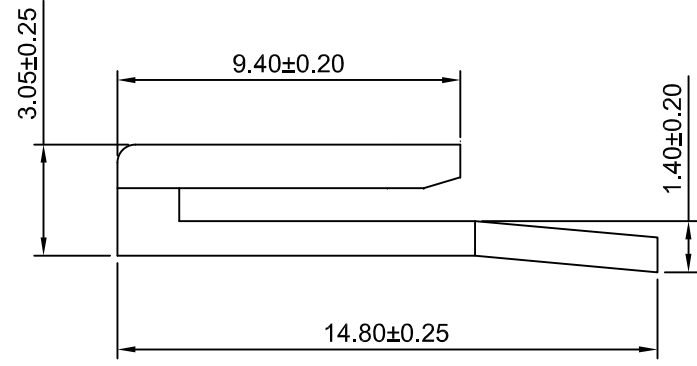

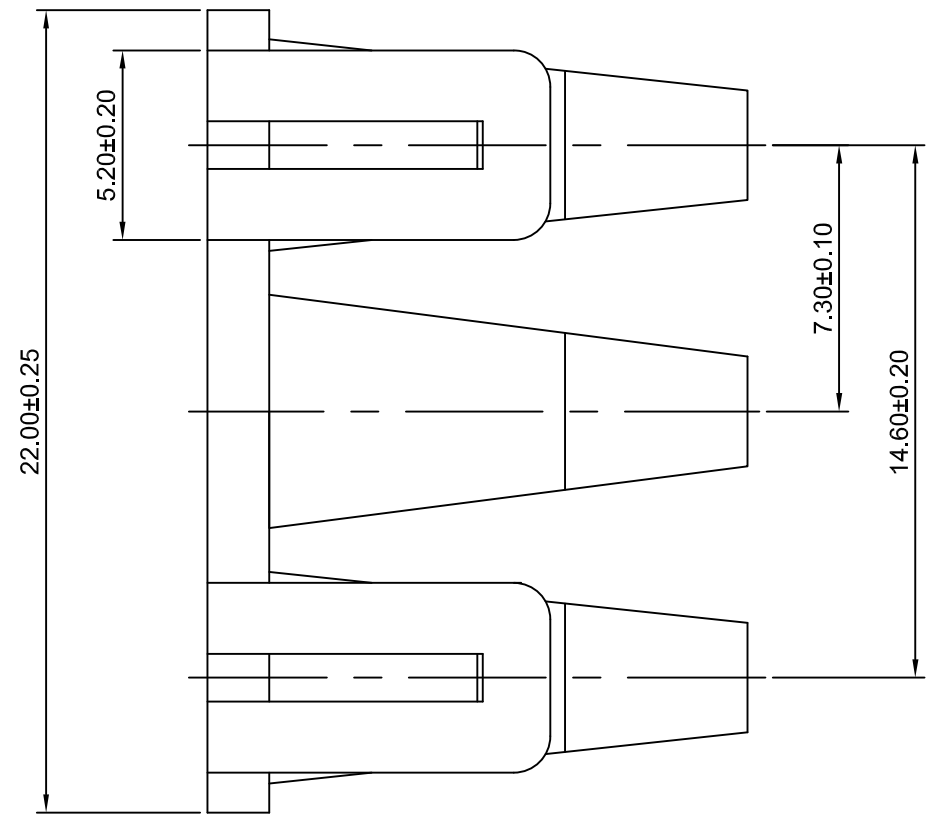

Ordering Information:
HDGC6202S-3P - **
 1 2

- 1.Part No.
- 2.Color:
 (blank):Natural
 RD:Red
 YL:Yellow
 BL:Blue



SPECIFICATIONS:
 Current Rating: 15A AC,DC
 Voltage Rating: 300V AC,DC
 Temperature Range: -25°C~+85°C
 Contact Resistance: 10mΩ Max
 Insulation Resistance: 1000MΩ Min
 Withstanding Voltage: 1500V AC/minute
 Material: Nylon 66,UL94V-2

 深圳市华德共创科技有限公司 SHENZHEN HUADE CO-CREATE TECHNOLOGY CO.,LTD TEL : 0755-27129737 FAX : 0755-29940187		TITLE: 1.80mm Width Retainer	
		PART NO: HDGC6202S-3P	
-TOLERANCES- UNLESS OTHERWISE SPECIFIED 公差参数表		 	DATE: 2012-12-20 SCALE: 5:1 UNIT: mm CODE NUMBER: A008
X.X ±0.30	X.X° ±3°	APPD: 核准: XIE	DATE: 2012-12-20
X.XX ±0.30	X.XX° ±2°	CHECK: 校对: WANG	SCALE: 5:1
X.XXX ±0.10	X.XXX° ±1°	DRAW: 绘图: WANG	UNIT: mm