

A B C D E F

修订 REV	标记 MARK	修改摘要 REVISION DESCRIPTION	签名 SIGNATURE	日期 DATE
AO		NEW RELEASE	WANG	2012-12-25

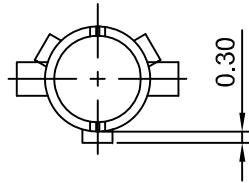
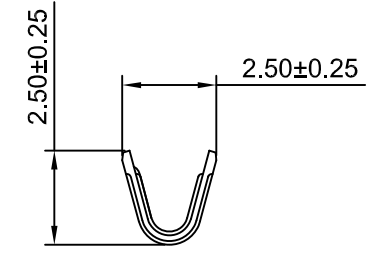
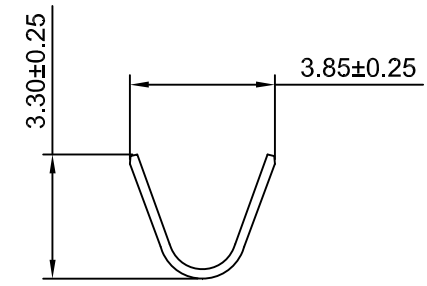
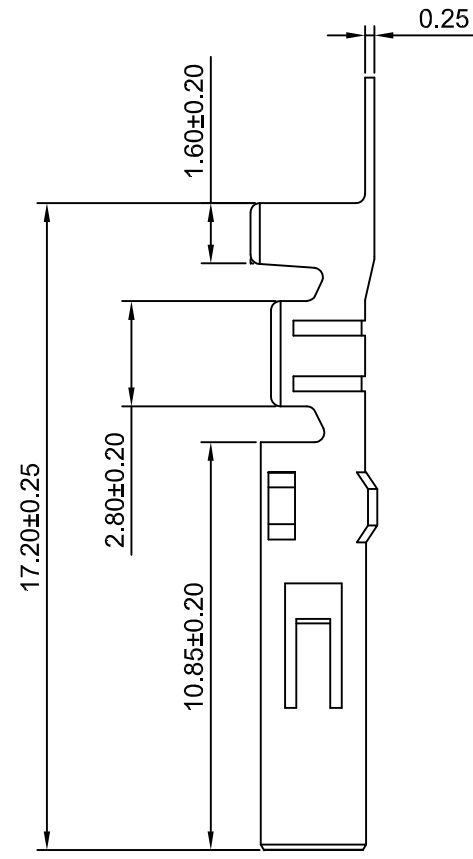
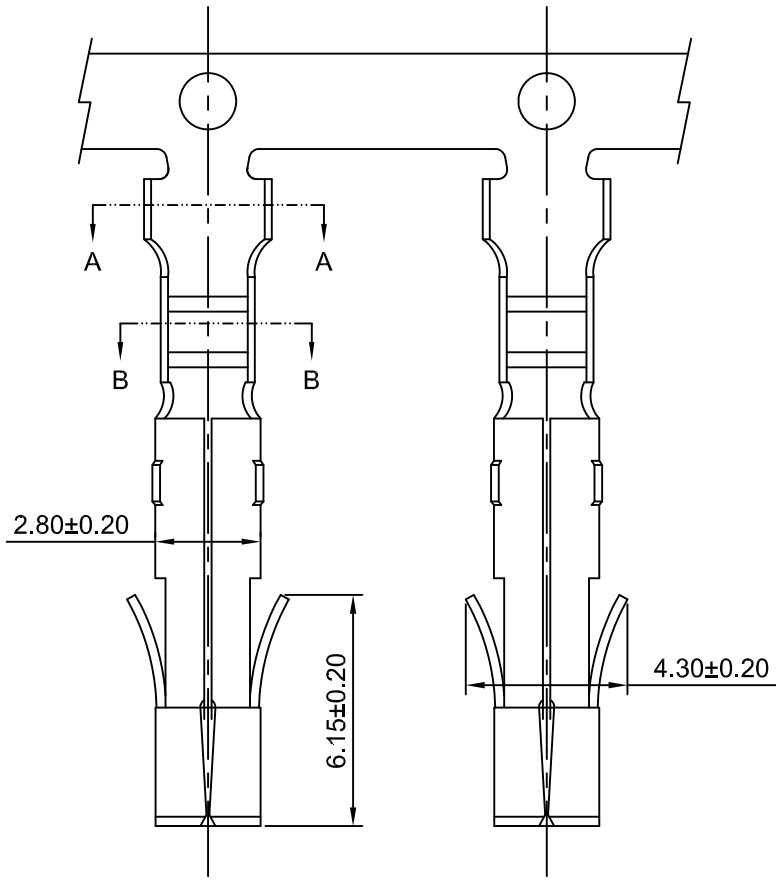

Ordering information & Specifications

Unit:mm

Part No	Wire Range	Insultion O.D.	Material	Finish	Qty/reel
HDGC5083-TB	AWG#18-#24	2.50mm(max)	Brass	Tin over Nickel	7,000 PCS
HDGC5083-TP	AWG#18-#24	2.50mm(max)	Phosphor Bronze	Tin over Nickel	7,000 PCS
HDGC5083-GB	AWG#18-#24	2.50mm(max)	Brass	Gold over Nickel	7,000 PCS
HDGC5083-GP	AWG#18-#24	2.50mm(max)	Phosphor Bronze	Gold over Nickel	7,000 PCS

HDGC 深圳市华德共创科技有限公司
 SHENZHEN HUADE CO-CREATE TECHNOLOGY CO.,LTD
 TEL : 0755-27129737 FAX : 0755-29940187

-TOLERANCES- UNLESS OTHERWISE SPECIFIED 公差参数表					TITLE: 5.08mm Pitch 产品名称: Crimp Terminal				
X.X	±0.30	X.X°	±3°	APPD: 核准:	XIE				
X.XX	±0.30	X.XX°	±2°	CHECK: 校对:	WANG	DATE	SCALE	UNIT	CODE NUMBER
X.XXX	±0.10	X.XXX°	±1°	DRAW: 绘图:	WANG	2012-12-25	5:1	mm	A008

A B C D E F

修订 REV	标记 MARK	修改摘要 REVISION DESCRIPTION	签名 SIGNATURE	日期 DATE
AO		NEW RELEASE	WANG	2016-05-25

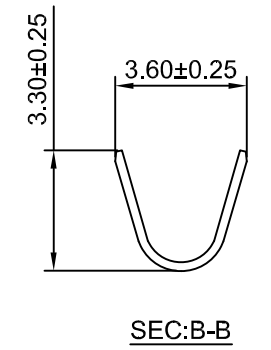
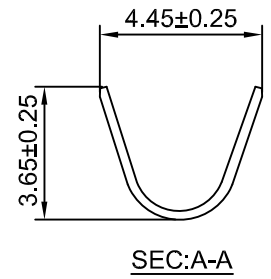
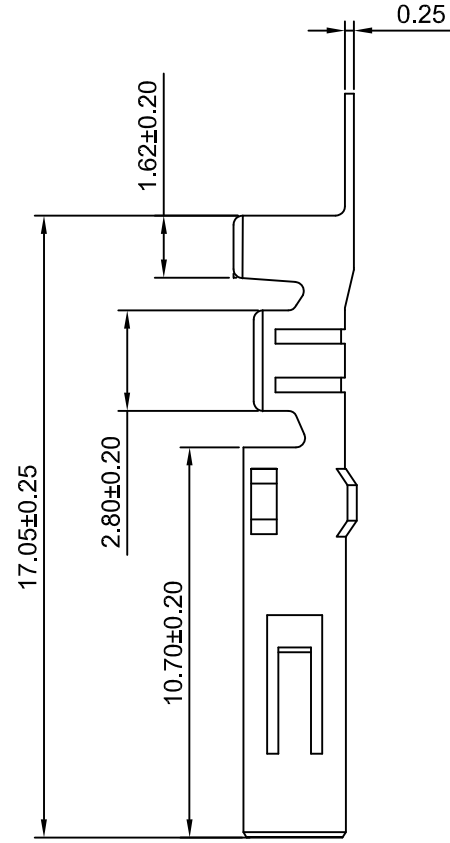
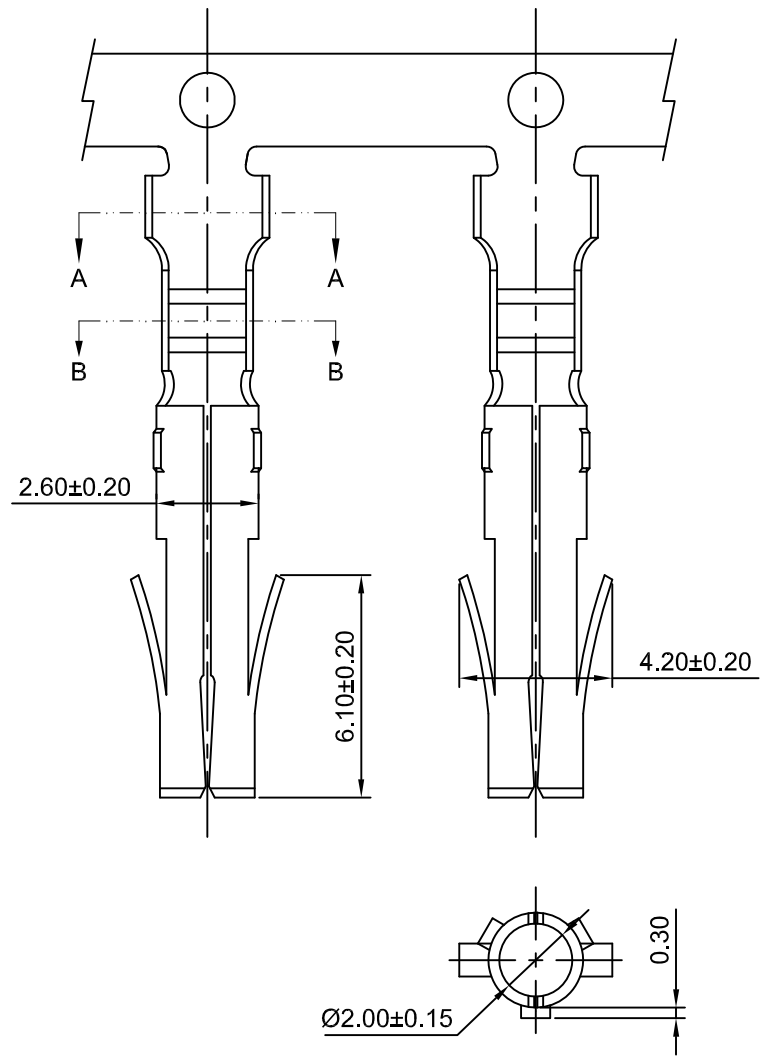



Ordering information & Specifications

Part No	Wire Range	Insultion O.D.	Material	Finish	Qty/reel
HDGC5083F-TB-H	AWG#14-#20	3.30mm(max)	Brass	Tin over Nickel	6,000 PCS
HDGC5083F-TP-H	AWG#14-#20	3.30mm(max)	Phosphor Bronze	Tin over Nickel	6,000 PCS

Unit:mm



深圳市华德共创科技有限公司
 SHENZHEN HUADE CO-CREATE TECHNOLOGY CO.,LTD
 TEL : 0755-27129737 FAX : 0755-29940187

-TOLERANCES- UNLESS OTHERWISE SPECIFIED 公差参数表				 	TITLE: 5.08mm Pitch 产品名称: Crimp Terminal			
X.X	±0.30	X.X°	±3°	APPD: 核准: XIE	PART NO: 产品编号: HDGC5083F-T-H			
X.XX	±0.30	X.XX°	±2°	CHECK: 校对: WANG	DATE	SCALE	UNIT	CODE NUMBER
X.XXX	±0.10	X.XXX°	±1°	DRAW: 绘图: WANG	2016-05-25	5:1	mm	A008

修订 REV	标记 MARK	修改摘要 REVISION DESCRIPTION	签名 SIGNATURE	日期 DATE
AO		NEW RELEASE	WANG	2012-12-25

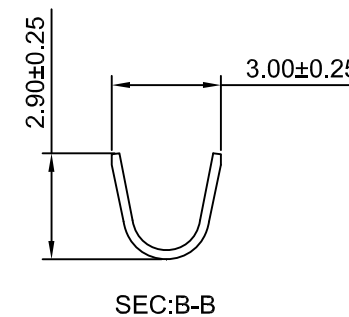
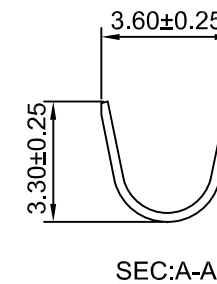
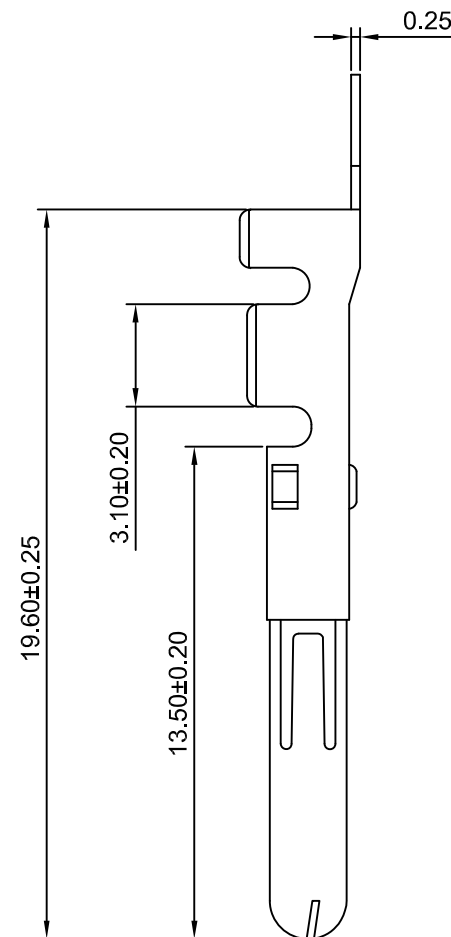
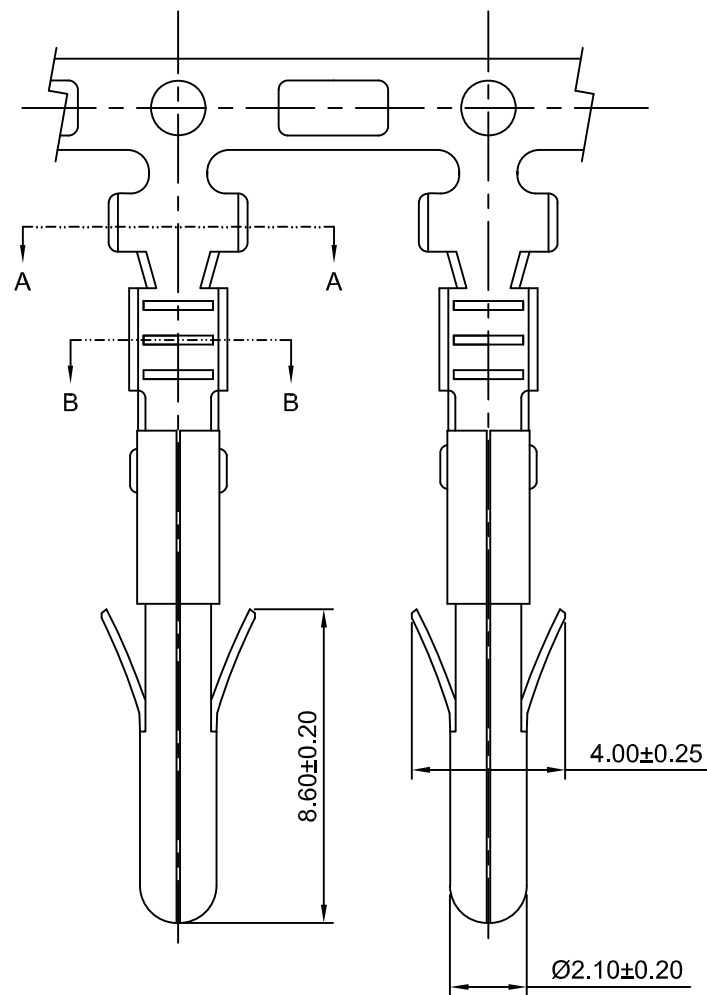

Ordering information & Specifications

Unit:mm

Part No	Wire Range	Insultion O.D.	Material	Finish	Qty/reel
HDGC5083M-TB	AWG#18-#24	2.50mm(max)	Brass	Tin over Nickel	7,000 PCS
HDGC5083M-TP	AWG#18-#24	2.50mm(max)	Phosphor Bronze	Tin over Nickel	7,000 PCS
HDGC5083M-GB	AWG#18-#24	2.50mm(max)	Brass	Gold over Nickel	7,000 PCS
HDGC5083M-GP	AWG#18-#24	2.50mm(max)	Phosphor Bronze	Gold over Nickel	7,000 PCS

Optional Gold plating available but MOQ requested



深圳市华德共创科技有限公司

SHENZHEN HUADE CO-CREATE TECHNOLOGY CO.,LTD

TEL : 0755-27129737 FAX : 0755-29940187

-TOLERANCES- UNLESS OTHERWISE SPECIFIED 公差参数表					TITLE: 5.08mm Pitch 产品名称: Crimp Terminal				
X.X	±0.30	X.X°	±3°	APPD: 核准:	XIE				
X.XX	±0.30	X.XX°	±2°	CHECK: 校对:	WANG	DATE	SCALE	UNIT	CODE NUMBER
X.XXX	±0.10	X.XXX°	±1°	DRAW: 绘图:	WANG	2012-12-25	5:1	mm	A008

PART NO: HDGC5083M-T
产品编号:

修订 REV	标记 MARK	修改摘要 REVISION DESCRIPTION	签名 SIGNATURE	日期 DATE
AO		NEW RELEASE	WANG	2012-12-25

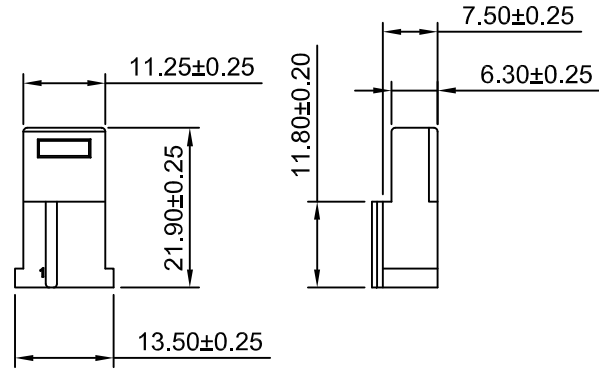
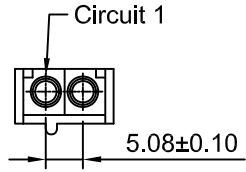

HDGC5083HF-2P

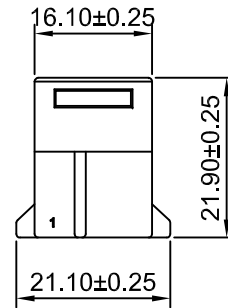
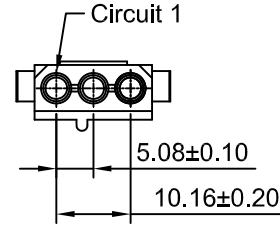

HDGC5083HF-3P

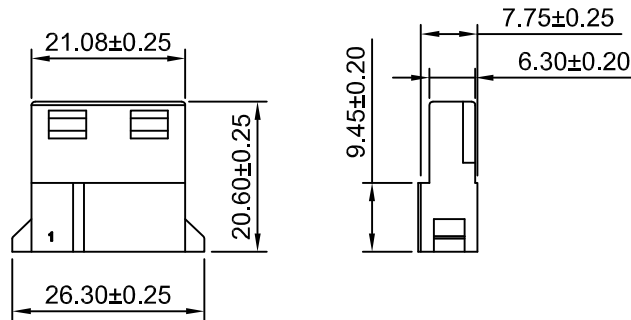
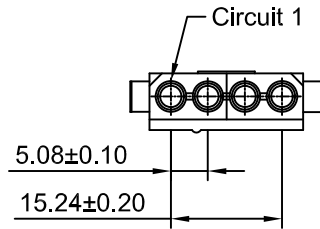
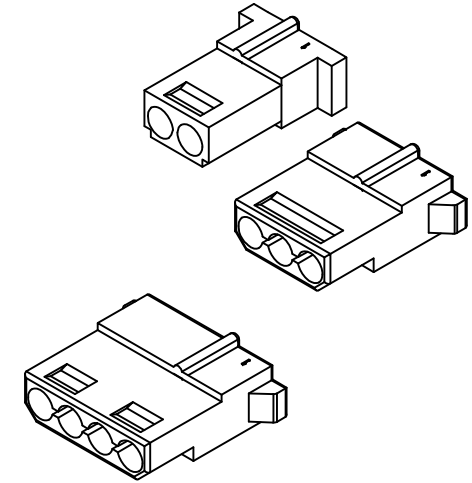

HDGC5083HF-4P

SPECIFICATIONS:

Current Rating: 7A AC,DC
Voltage Rating: 250V AC,DC
Temperature Range: -25°C ~ +85°C
Contact Resistance: 10mΩ Max
Insulation Resistance: 1000MΩ Min
Withstanding Voltage: 1500VAC/minute
Material: Nylon 66,UL94V-2(Natural)



深圳市华德共创科技有限公司

SHENZHEN HUADE CO-CREATE TECHNOLOGY CO.,LTD

TEL : 0755-27129737 FAX : 0755-29940187

-TOLERANCES- UNLESS OTHERWISE SPECIFIED 公差参数表						TITLE: 5.08mm Pitch Housing 产品名称: 5.08mm Pitch Housing			
X.X	±0.30	X.X°	±3°	APPD: 核准:	XIE	PART NO: 产品编号: HDGC5083HF-XP			
X.XX	±0.30	X.XX°	±2°	CHECK: 校对:	WANG	DATE	SCALE	UNIT	CODE NUMBER
X.XXX	±0.10	X.XXX°	±1°	DRAW: 绘图:	WANG	2012-12-25	1:1	mm	A008

修订 REV	标记 MARK	修改摘要 REVISION DESCRIPTION	签名 SIGNATURE	日期 DATE
AO		NEW RELEASE	WANG	2012-12-25

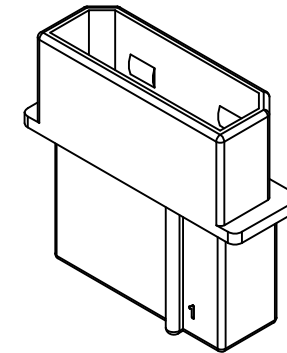
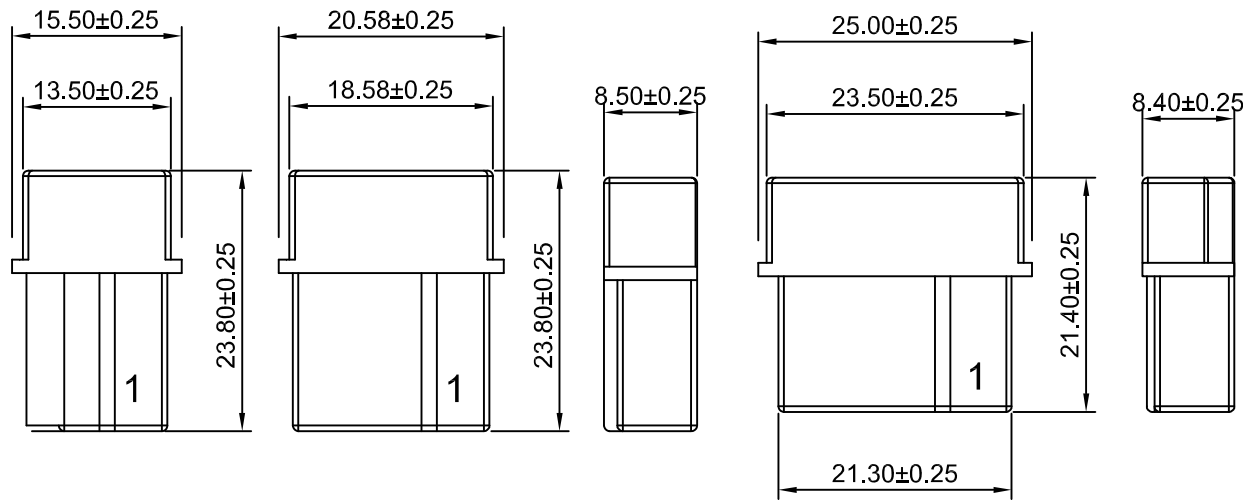
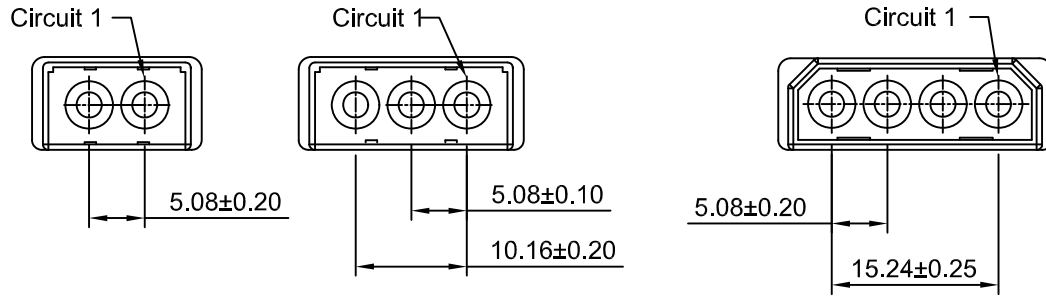

SPECIFICATIONS:
 Current Rating: 7A AC,DC
 Voltage Rating: 250V AC,DC
 Temperature Range: -25°C ~ +85°C
 Contact Resistance: 10mΩ Max
 Insulation Resistance: 1000MΩ Min
 Withstanding Voltage: 1500VAC/minute
 Material: Nylon 66,UL94V-2(Natural)

2P~3P

4P



深圳市华德共创科技有限公司

SHENZHEN HUADE CO-CREATE TECHNOLOGY CO.,LTD

TEL : 0755-27129737 FAX : 0755-29940187

-TOLERANCES- UNLESS OTHERWISE SPECIFIED 公差参数表						TITLE: 产品名称 : 5.08mm Pitch Housing			
X.X	±0.30	X.X°	±3°	APPD: 核准 :	XIE	PART NO: 产品编号 : HDGC5083HM-XP			
X.XX	±0.30	X.XX°	±2°	CHECK: 校对 :	WANG	DATE	SCALE	UNIT	CODE NUMBER
X.XXX	±0.10	X.XXX°	±1°	DRAW: 绘图 :	WANG	2012-12-25	1.5:1	mm	A008

修订 REV	标记 MARK	修改摘要 REVISION DESCRIPTION	签名 SIGNATURE	日期 DATE
AO		NEW RELEASE	WANG	2012-12-25

Ordering Information:

HDGC5083WV-XP- **
1 2

1.Part No.

2.Material:

(blank):Nylon 66,UL94V-2

V0:Nylon 66,UL94V-0

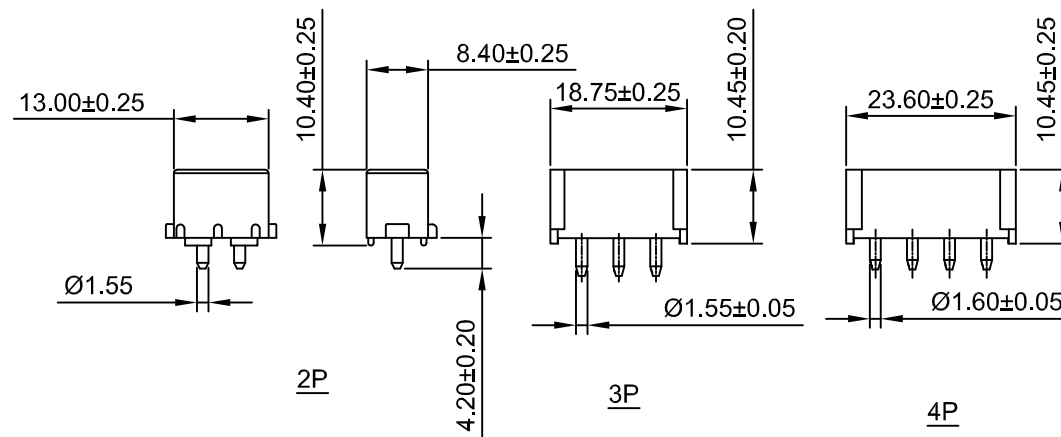
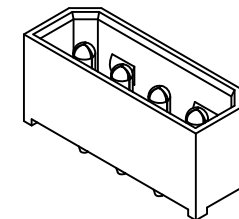
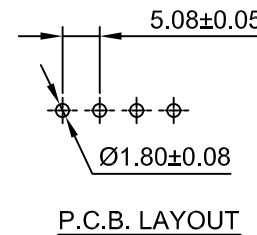
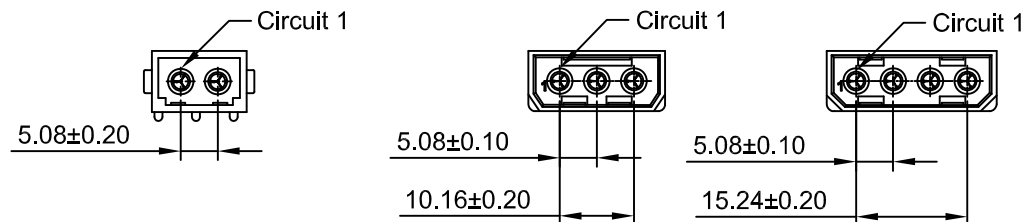

SPECIFICATIONS:

Current Rating: 7A AC,DC
Voltage Rating: 250V AC,DC
Temperature Range: -25°C ~ +85°C
Contact Resistance:10mΩ Max
Insulation Resistance: 1000MΩ Min
Withstanding Voltage: 1500V AC/minute
Pin Material: Brass/Tin over Nickel
Material: Nylon 66,UL94V-2(Natural)

HDGC 深圳市华德共创科技有限公司
SHENZHEN HUADE CO-CREATE TECHNOLOGY CO.,LTD
TEL : 0755-27129737 FAX : 0755-29940187

-TOLERANCES- UNLESS OTHERWISE SPECIFIED 公差参数表					TITLE: 5.08mm Pitch 产品名称: 180° Wafer				
X.X	±0.30	X.X°	±3°	APPD: 核准:	XIE				
X.XX	±0.30	X.XX°	±2°	CHECK: 校对:	WANG	DATE	SCALE	UNIT	CODE NUMBER
X.XXX	±0.10	X.XXX°	±1°	DRAW: 绘图:	WANG	2012-12-25	1:1	mm	A008

修订 REV	标记 MARK	修改摘要 REVISION DESCRIPTION	签名 SIGNATURE	日期 DATE
AO		NEW RELEASE	WANG	2012-12-25

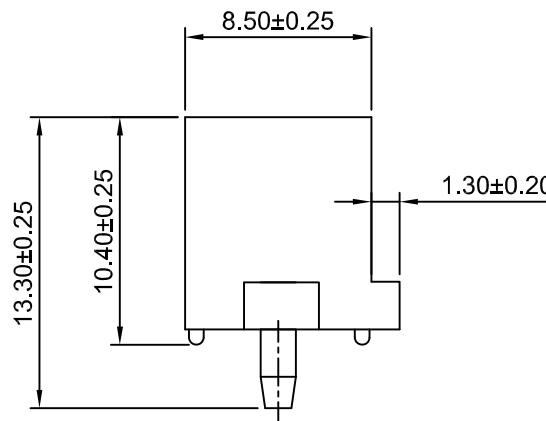
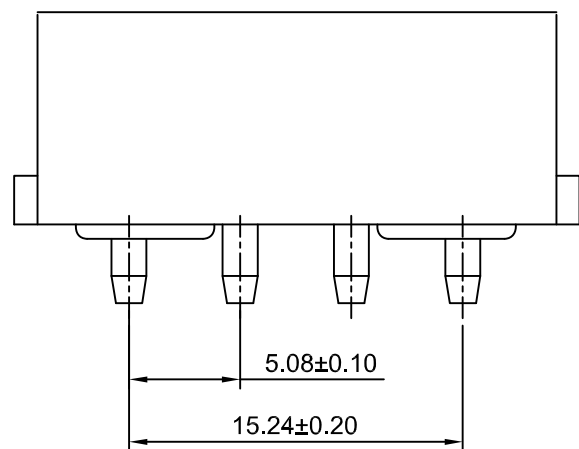
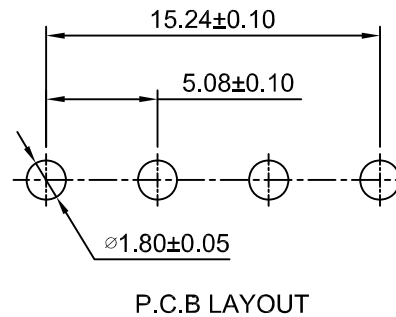
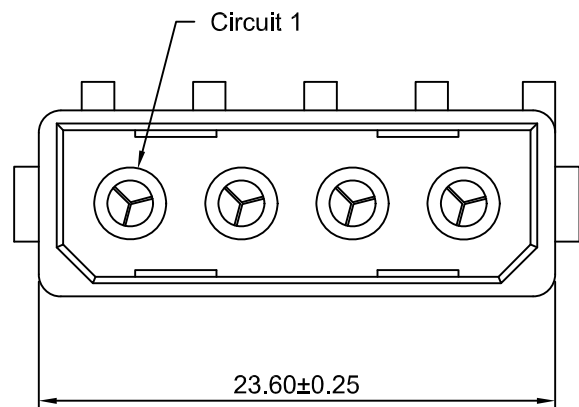

SPECIFICATIONS:

Current Rating: 10A AC,DC
Voltage Rating: 250V AC,DC
Temperature Range: -25°C ~ +85°C
Contact Resistance: 10mΩ Max
Insulation Resistance: 1000MΩ Min
Withstanding Voltage: 1500V AC/minute
Pin Material: Brass/Tin over Nickel
Material: Nylon 66,UL94V-2(Natural)



深圳市华德共创科技有限公司

SHENZHEN HUADE CO-CREATE TECHNOLOGY CO.,LTD

TEL : 0755-27129737 FAX : 0755-29940187

-TOLERANCES- UNLESS OTHERWISE SPECIFIED 公差参数表				 		TITLE: 5.08mm Pitch 产品名称: 180° Wafer			
X.X	±0.30	X.X°	±3°	APPD: 核准:	XIE	PART NO: 产品编号: HDGC5083WV-F-4P			
X.XX	±0.30	X.XX°	±2°	CHECK: 校对:	WANG	DATE	SCALE	UNIT	CODE NUMBER
X.XXX	±0.10	X.XXX°	±1°	DRAW: 绘图:	WANG	2012-12-25	3:1	mm	A008

修订 REV	标记 MARK	修改摘要 REVISION DESCRIPTION	签名 SIGNATURE	日期 DATE
AO		NEW RELEASE	WANG	2012-12-25

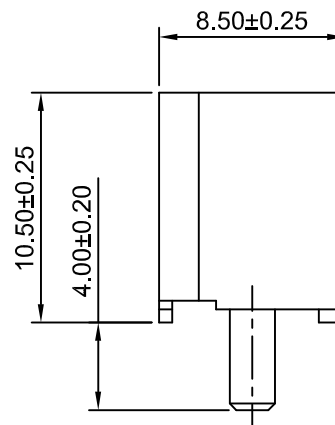
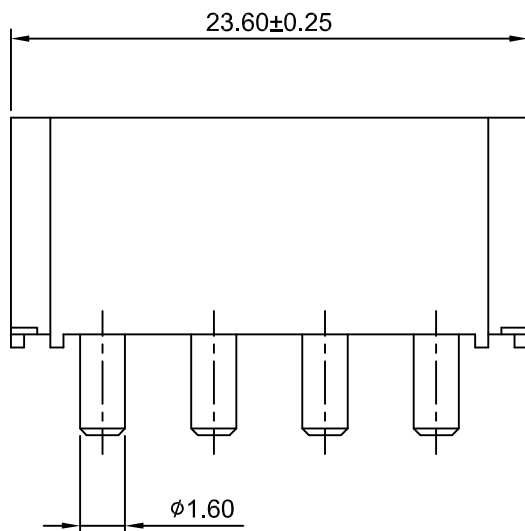
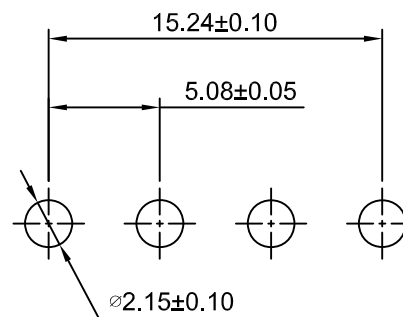
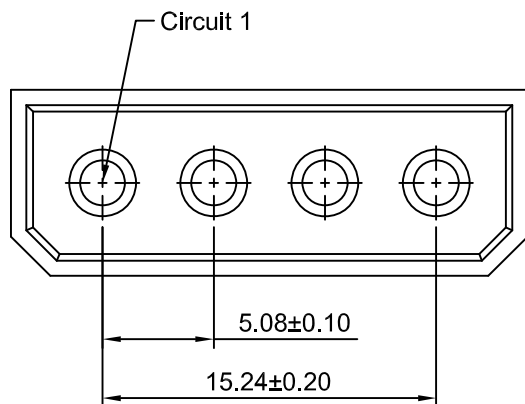

SPECIFICATIONS:
 Current Rating: 10A AC,DC
 Voltage Rating: 250V AC,DC
 Temperature Range: -25°C ~ +85°C
 Contact Resistance: 10mΩ Max
 Insulation Resistance: 1000MΩ Min
 Withstanding Voltage: 1500V AC/minute
 Pin Material: Brass/Tin over Nickel
 Material: Nylon 66,UL94V-0(Black)



深圳市华德共创科技有限公司

SHENZHEN HUADE CO-CREATE TECHNOLOGY CO.,LTD

TEL : 0755-27129737 FAX : 0755-29940187

-TOLERANCES- UNLESS OTHERWISE SPECIFIED 公差参数表				 		TITLE: 5.08mm Pitch 产品名称: 180° Wafer			
X.X	±0.30	X.X°	±3°	APPD: 核准:	XIE	PART NO: 产品编号: HDGC5083WV-4P-R			
X.XX	±0.30	X.XX°	±2°	CHECK: 校对:	WANG	DATE	SCALE	UNIT	CODE NUMBER
X.XXX	±0.10	X.XXX°	±1°	DRAW: 绘图:	WANG	2012-12-25	3:1	mm	A008

修订 REV	标记 MARK	修改摘要 REVISION DESCRIPTION	签名 SIGNATURE	日期 DATE
AO		NEW RELEASE	WANG	2012-12-25

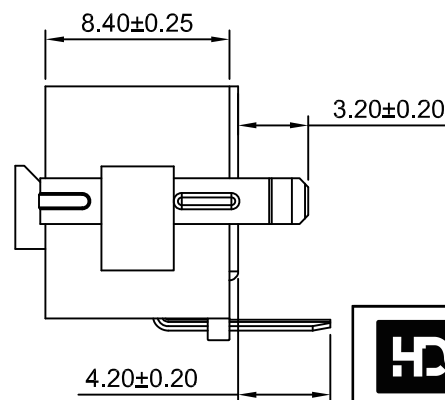
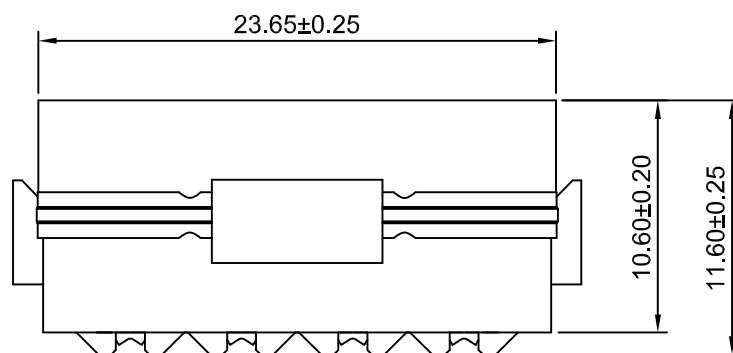
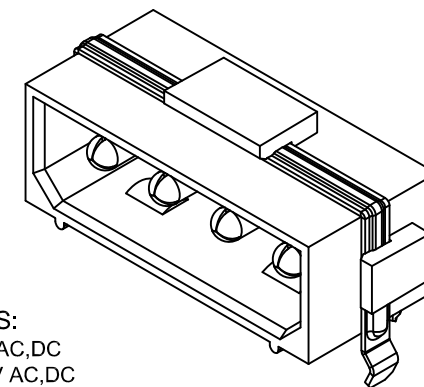
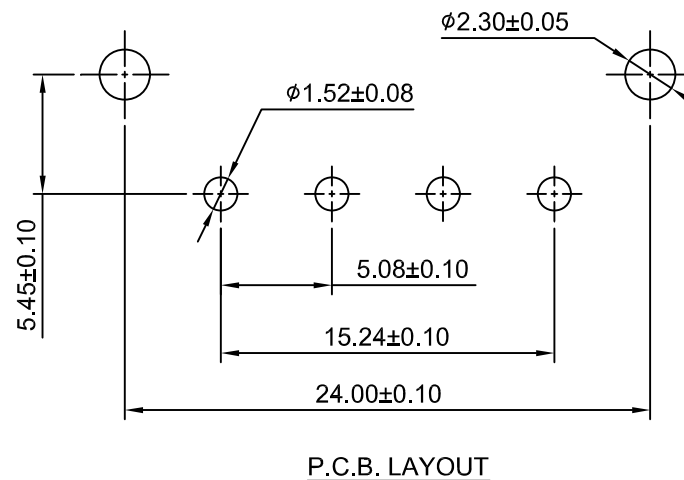
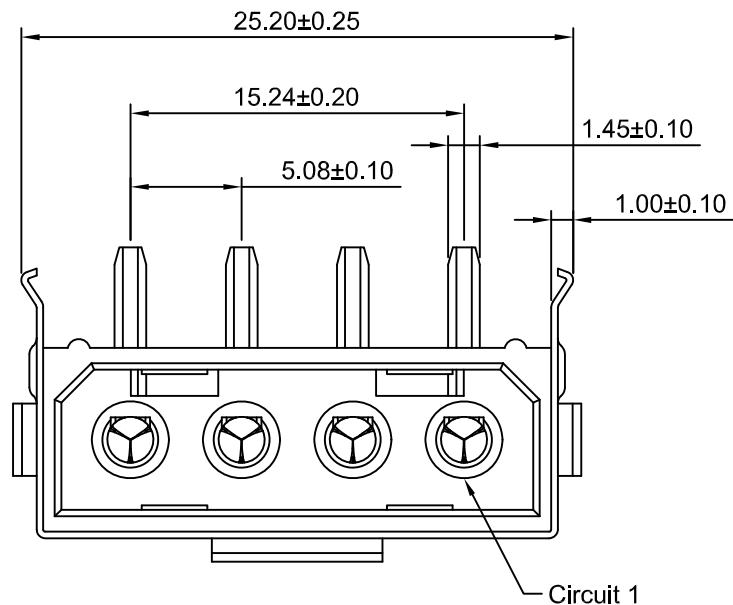

SPECIFICATIONS:

Current Rating: 10A AC,DC
Voltage Rating: 250V AC,DC
Temperature Range: -25°C ~ +85°C
Contact Resistance: 10mΩ Max
Insulation Resistance: 1000MΩ Min
Withstanding Voltage: 1500V AC/minute
Pin Material: Brass/Tin over Nickel
Metal Band: Brass/Tin over Nickel
Material: Nylon 66,UL94V-0(Black)



深圳市华德共创科技有限公司

SHENZHEN HUADE CO-CREATE TECHNOLOGY CO.,LTD

TEL : 0755-27129737 FAX : 0755-29940187

-TOLERANCES- UNLESS OTHERWISE SPECIFIED 公差参数表						TITLE: 5.08mm Pitch 产品名称: 90° Wafer			
X.X	±0.30	X.X°	±3°	APPD: 核准:	XIE	PART NO: 产品编号: HDGC5083WR-4P			
X.XX	±0.30	X.XX°	±2°	CHECK: 校对:	WANG	DATE	SCALE	UNIT	CODE NUMBER
X.XXX	±0.10	X.XXX°	±1°	DRAW: 绘图:	WANG	2012-12-25	3:1	mm	A008

修订 REV	标记 MARK	修改摘要 REVISION DESCRIPTION	签名 SIGNATURE	日期 DATE
AO		NEW RELEASE	WANG	2012-12-25

Ordering Information:

HDGC5083WR-F-XP-*-****
 1 2 3

- Part No.
- Material:
 (blank):Nylon 66,UL94V-2
 V0:Nylon 66,UL94V-0
 GWT:Nylon 66,UL94V-0,GWT 750°C
- Finish:
 (blank):Tin over Nickel
 G:Gold over Nickel

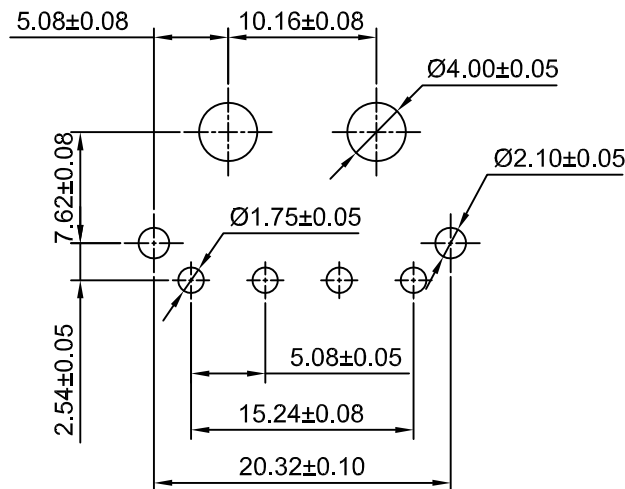
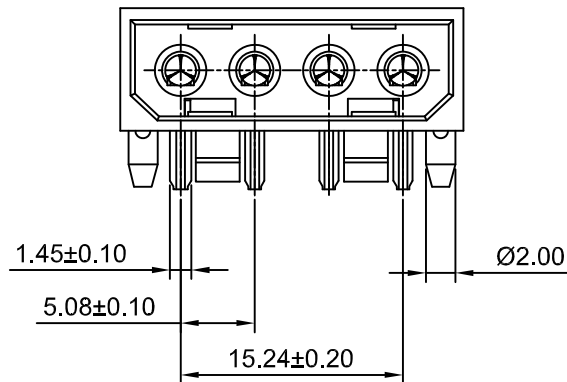

P.C.B. LAYOUT

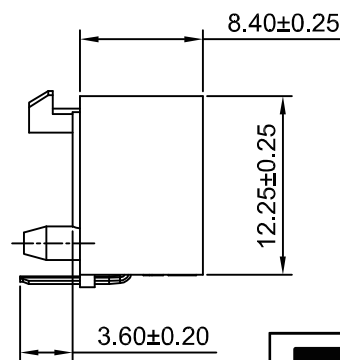
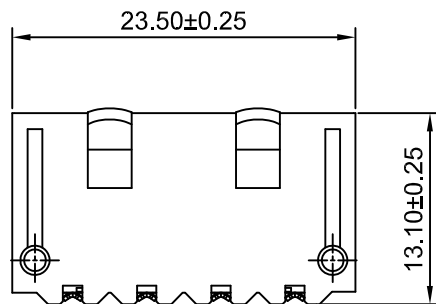
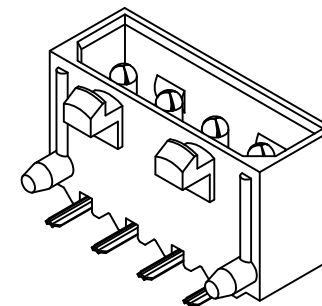

SPECIFICATIONS:

- Current Rating: 10A AC,DC
- Voltage Rating: 250V AC,DC
- Temperature Range: -25°C ~ +85°C
- Contact Resistance: 10mΩ Max
- Insulation Resistance: 1000MΩ Min
- Withstanding Voltage: 1500V AC/minute
- Pin Material: Brass/Tin over Nickel
- Material: Nylon 66,UL94V-2(Natural)



深圳市华德共创科技有限公司

SHENZHEN HUADE CO-CREATE TECHNOLOGY CO.,LTD

TEL : 0755-27129737 FAX : 0755-29940187

-TOLERANCES- UNLESS OTHERWISE SPECIFIED 公差参数表						TITLE: 产品名称 : 5.08mm Pitch 90° Wafer			
X.X	±0.30	X.X°	±3°	APPD: 核准 :	XIE	PART NO: 产品编号 : HDGC5083WR-F-4P			
X.XX	±0.30	X.XX°	±2°	CHECK: 校对 :	WANG	DATE	SCALE	UNIT	CODE NUMBER
X.XXX	±0.10	X.XXX°	±1°	DRAW: 绘图 :	WANG	2012-12-25	2:1	mm	A008

修订 REV	标记 MARK	修改摘要 REVISION DESCRIPTION	签名 SIGNATURE	日期 DATE
AO		NEW RELEASE	WANG	2012-12-25

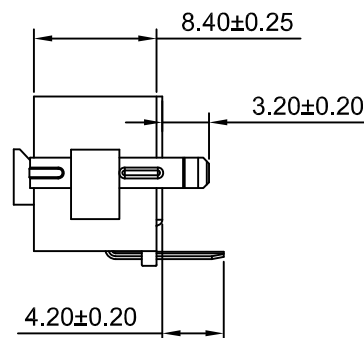
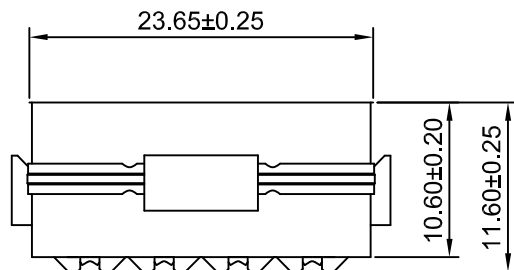
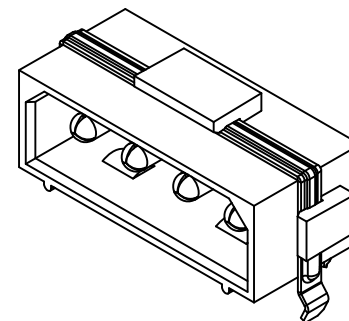
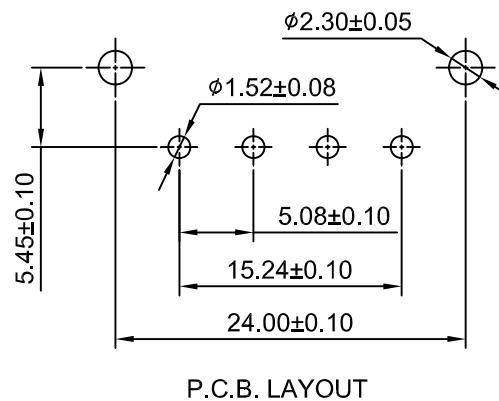
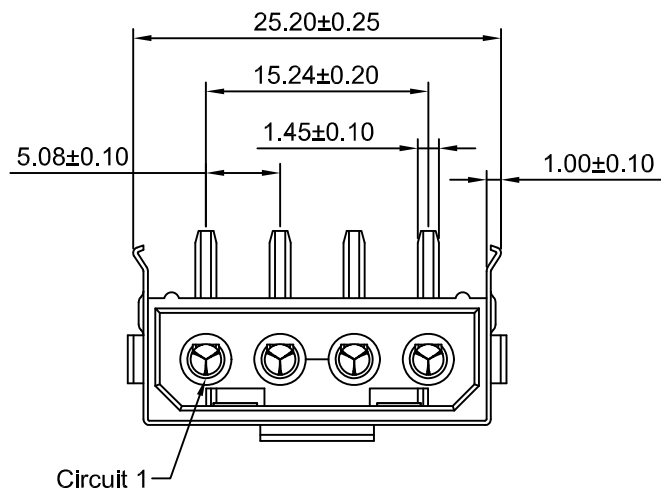

SPECIFICATIONS:

Current Rating: 10A AC,DC
Voltage Rating: 250V AC,DC
Temperature Range: -25°C ~ +85°C
Contact Resistance: 10mΩ Max
Insulation Resistance: 1000MΩ Min
Withstanding Voltage: 1500V AC/minute
Pin Material: Brass/Tin over Nickel
Metal Band: Brass/Tin over Nickel
Material: Nylon 66,UL94V-0(Black)

深圳市华德共创科技有限公司 SHENZHEN HUADE CO-CREATE TECHNOLOGY CO.,LTD TEL : 0755-27129737 FAX : 0755-29940187				TITLE: 5.08mm Pitch 产品名称: 90° Wafer	
				PART NO: HDGC5083WR-4P-R 产品编号:	
X.X ±0.30 X.X° ±3°	APPD: 核准: XIE	DATE	SCALE	UNIT	CODE NUMBER
X.XX ±0.30 X.XX° ±2°	CHECK: 校对: WANG	2012-12-25	2:1	mm	A008
X.XXX ±0.10 X.XXX° ±1°	DRAW: 绘图: WANG				

-TOLERANCES-
UNLESS OTHERWISE SPECIFIED
公差参数表

