

修订 REV	标记 MARK	修改摘要 REVISION DESCRIPTION	签名 SIGNATURE	日期 DATE
AO		NEW RELEASE	WANG	2012-04-16

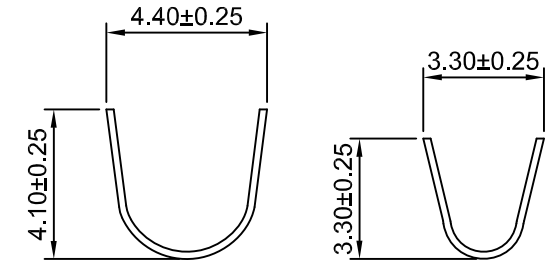

SEC:A-A

SEC:A-A

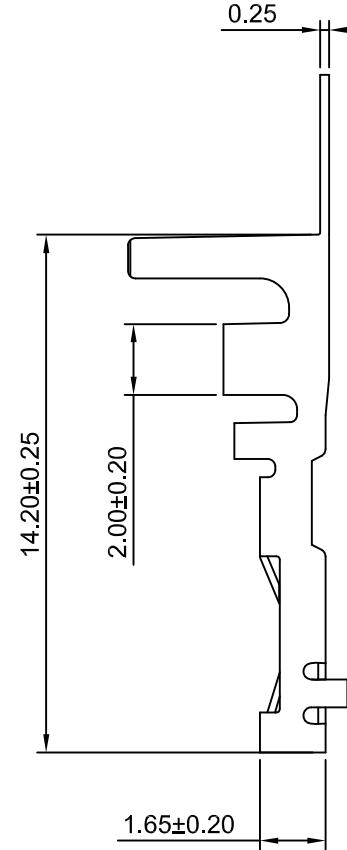
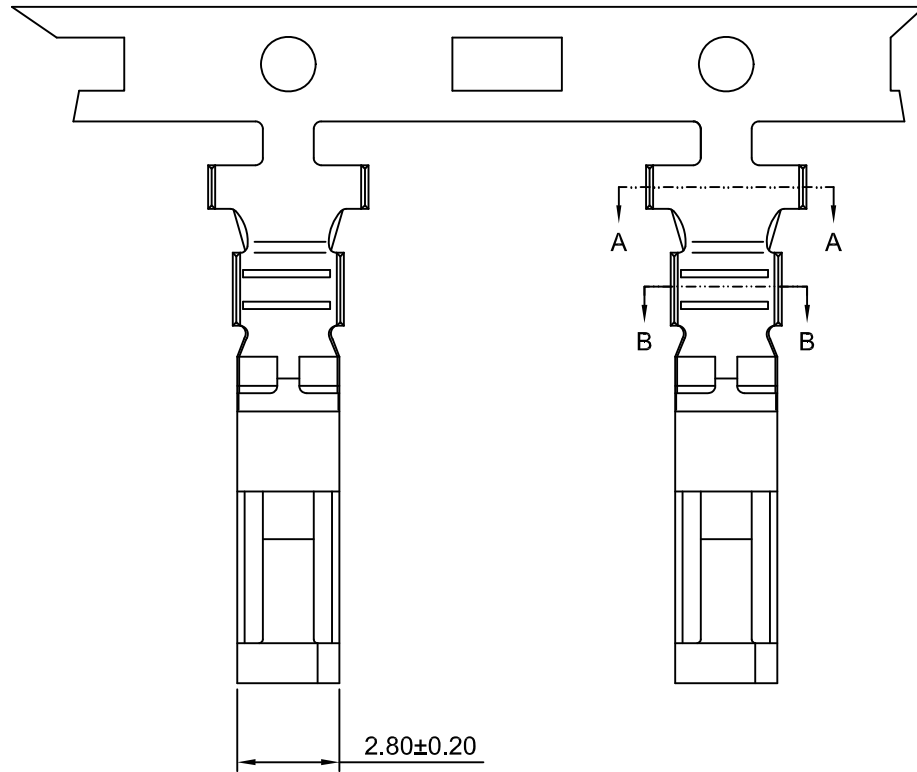
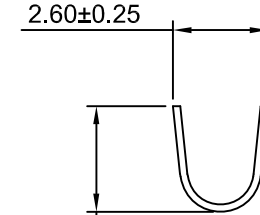

SEC:B-B

HDGC4501F-T

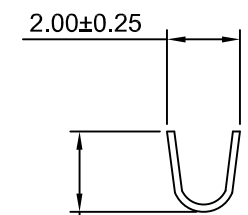

SEC:B-B

HDGC4501F-T-A

Ordering information & Specifications

Unit:mm

Part No	Wire Range	Insulation O.D.	Material	Finish	Qty/reel
HDGC4501F-TP	AWG#16-#20	3.40mm(max)	Phosphor Bronze	Tin over Nickel	4,000 PCS
HDGC4501F-GP	AWG#16-#20	3.40mm(max)	Phosphor Bronze	Gold over Nickel	4,000 PCS
HDGC4501F-TP-A	AWG#20-#26	2.50mm(max)	Phosphor Bronze	Tin over Nickel	4,000 PCS
HDGC4501F-GP-A	AWG#20-#26	2.50mm(max)	Phosphor Bronze	Gold over Nickel	4,000 PCS

Optional Gold plating available but MOQ requested



深圳市华德共创科技有限公司

SHENZHEN HUADE CO-CREATE TECHNOLOGY CO.,LTD

TEL : 0755-27129737 FAX : 0755-29940187

-TOLERANCES- UNLESS OTHERWISE SPECIFIED 公差参数表					TITLE: 产品名称: 4.50mm Pitch Crimp Terminal
X.X	±0.30	X.X°	±3°	APPD: 核准: XIE	PART NO: 产品编号: HDGC4501F-T
X.XX	±0.30	X.XX°	±2°	CHECK: 校对: WANG	DATE
X.XXX	±0.10	X.XXX°	±1°	DRAW: 绘图: WANG	SCALE
					UNIT
					CODE NUMBER
					A008

修订 REV	标记 MARK	修改摘要 REVISION DESCRIPTION	签名 SIGNATURE	日期 DATE
AO		NEW RELEASE	WANG	2012-04-16

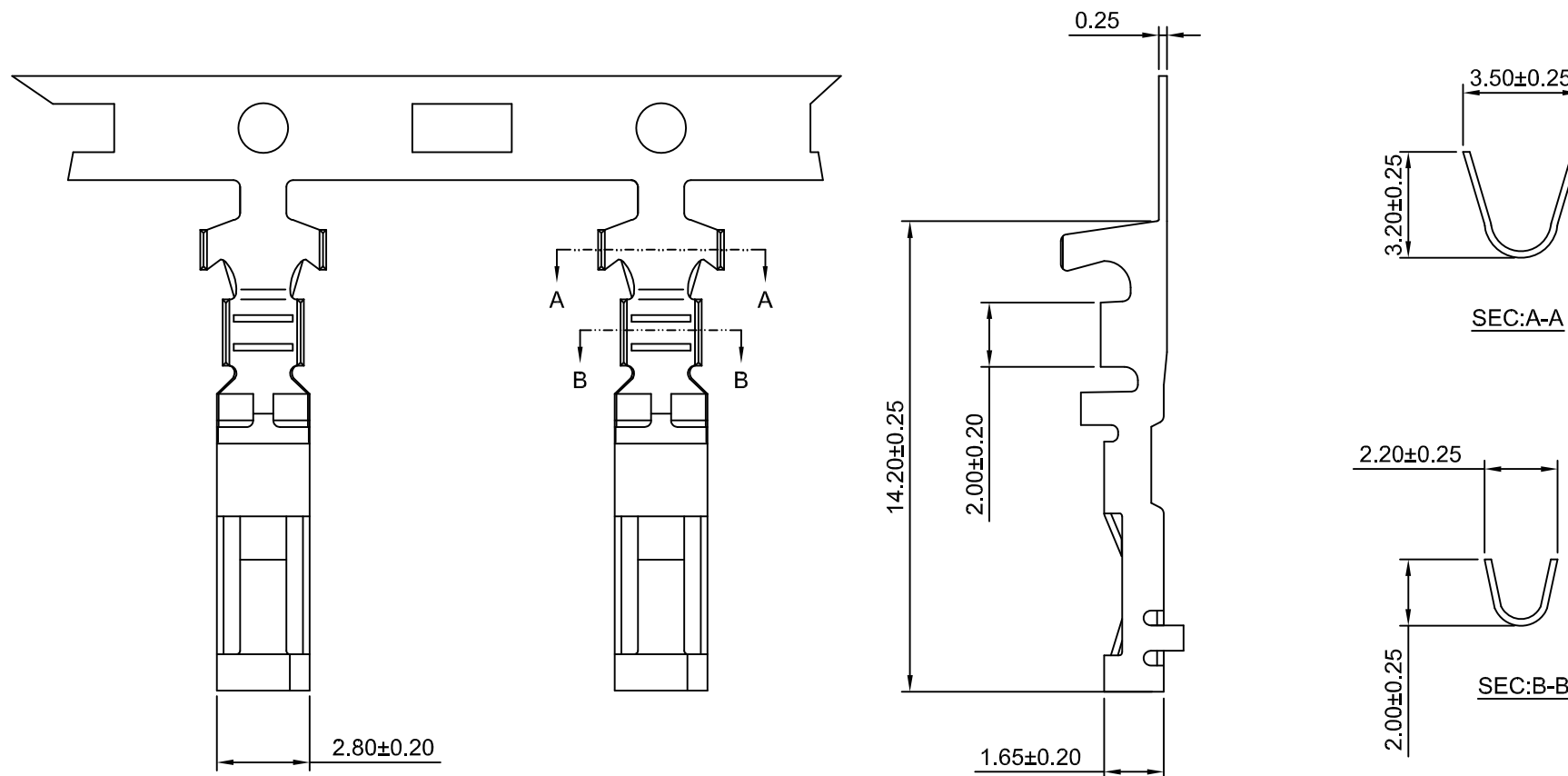

Ordering information & Specifications

Unit:mm

Part No	Wire Range	Insulation O.D.	Material	Finish	Qty/reel
HDGC4501F-TP-L	AWG#20-#26	2.50mm(max)	Phosphor Bronze	Tin over Nickel	4,000 PCS
HDGC4501F-GP-L	AWG#20-#26	2.50mm(max)	Phosphor Bronze	Gold over Nickel	4,000 PCS

Optional Gold plating available but MOQ requested



深圳市华德共创科技有限公司

SHENZHEN HUADE CO-CREATE TECHNOLOGY CO.,LTD

TEL : 0755-27129737 FAX : 0755-29940187

-TOLERANCES- UNLESS OTHERWISE SPECIFIED 公差参数表					TITLE: 4.50mm Pitch 产品名称: Crimp Terminal			
X.X	$\pm 0.30$	X.X°	$\pm 3^\circ$	APPD: 核准: XIE	PART NO: 产品编号: HDGC4501F-T-L			
X.XX	$\pm 0.30$	X.XX°	$\pm 2^\circ$	CHECK: 校对: WANG	DATE	SCALE	UNIT	CODE NUMBER
X.XXX	$\pm 0.10$	X.XXX°	$\pm 1^\circ$	DRAW: 绘图: WANG	2012-04-16	5:1	mm	A008

修订 REV	标记 MARK	修改摘要 REVISION DESCRIPTION	签名 SIGNATURE	日期 DATE
AO		NEW RELEASE	WANG	2012-04-16

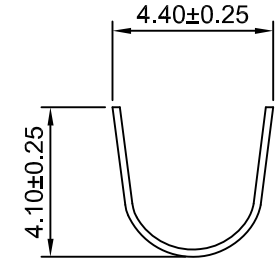
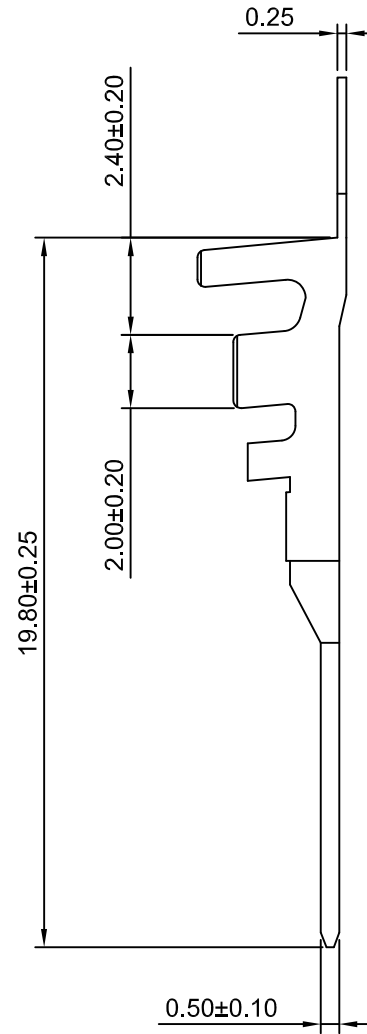
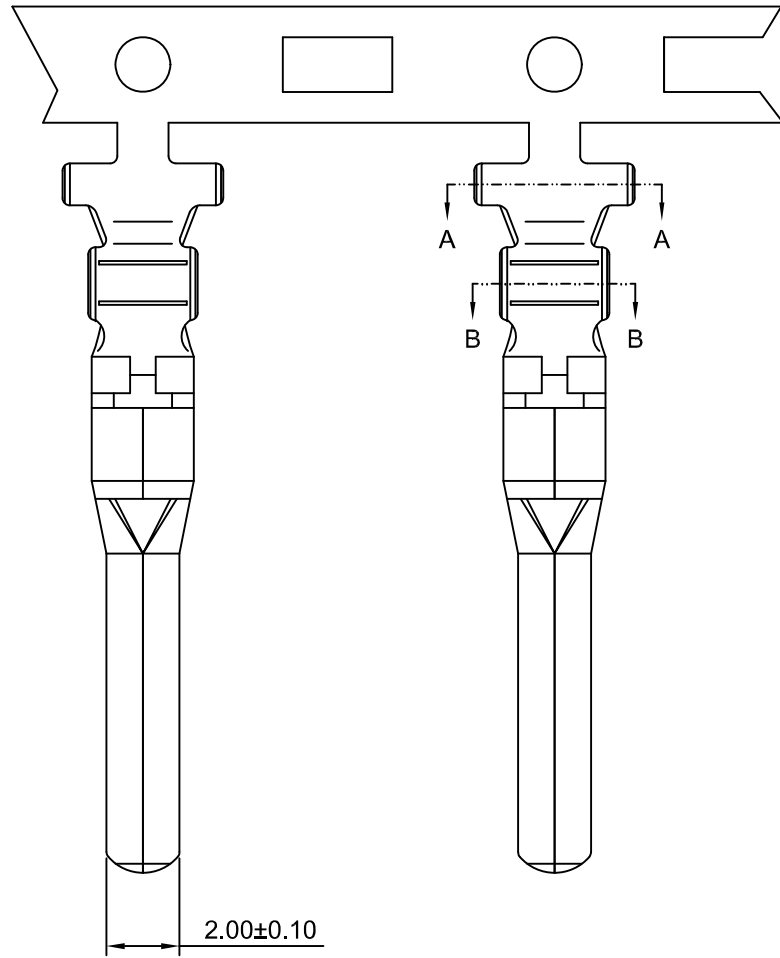

SEC:A-A

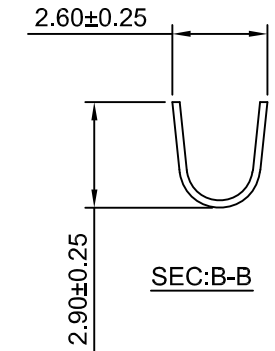

SEC:B-B

Ordering information & Specifications

Unit:mm

Part No	Wire Range	Insultion O.D.	Material	Finish	Qty/reel
HDGC4501M-TP	AWG#16-#20	3.40mm(max)	Phosphor Bronze	Tin over Nickel	4,000 PCS
HDGC4501M-GP	AWG#16-#20	3.40mm(max)	Phosphor Bronze	Gold over Nickel	4,000 PCS
HDGC4501M-TP-L	AWG#20-#26	2.50mm(max)	Phosphor Bronze	Tin over Nickel	4,000 PCS
HDGC4501M-GP-L	AWG#20-#26	2.50mm(max)	Phosphor Bronze	Gold over Nickel	4,000 PCS

Optional Gold plating available but MOQ requested



深圳市华德共创科技有限公司

SHENZHEN HUADE CO-CREATE TECHNOLOGY CO.,LTD

TEL : 0755-27129737 FAX : 0755-29940187

-TOLERANCES- UNLESS OTHERWISE SPECIFIED 公差参数表					TITLE: 产品名称: 4.50mm Pitch Crimp Terminal
X.X	±0.30	X.X°	±3°	APPD: 核准: XIE	PART NO: 产品编号: HDGC4501M-T
X.XX	±0.30	X.XX°	±2°	CHECK: 校对: WANG	DATE
X.XXX	±0.10	X.XXX°	±1°	DRAW: 绘图: WANG	SCALE
					UNIT
					CODE NUMBER
					A008

修订 REV	标记 MARK	修改摘要 REVISION DESCRIPTION	签名 SIGNATURE	日期 DATE
AO		NEW RELEASE	WANG	2012-04-16

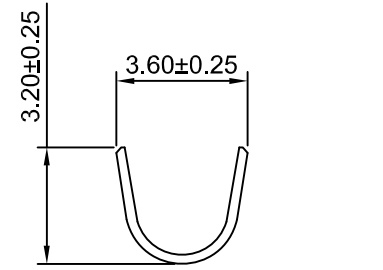
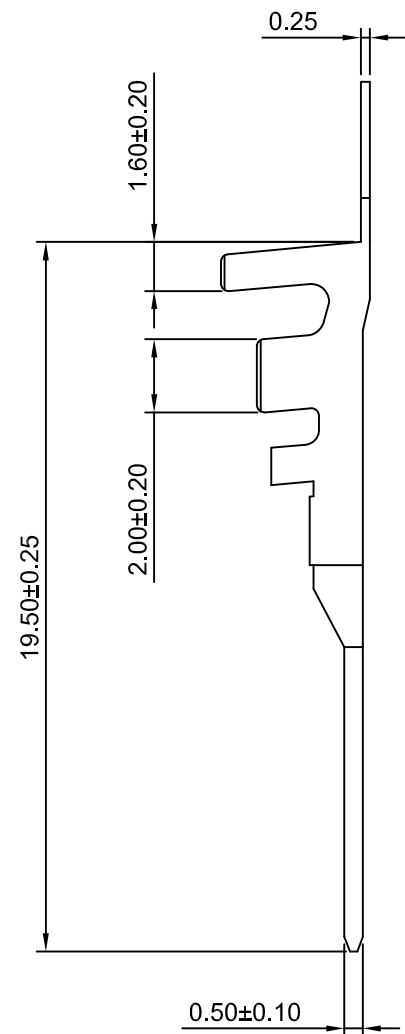
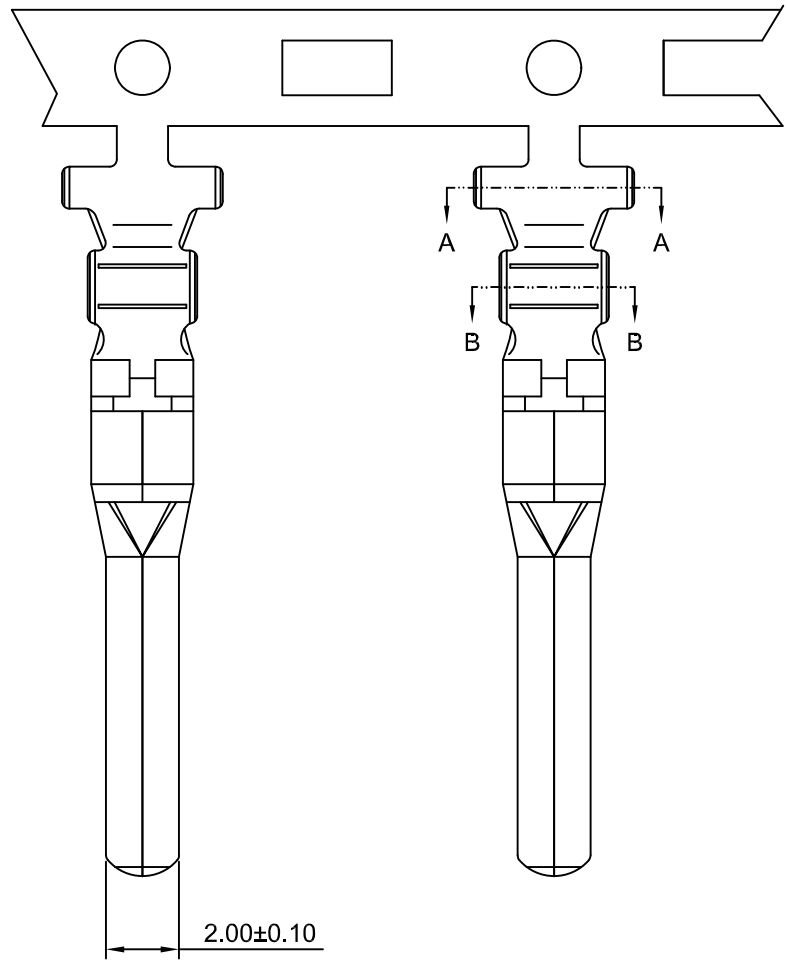

SEC:A-A

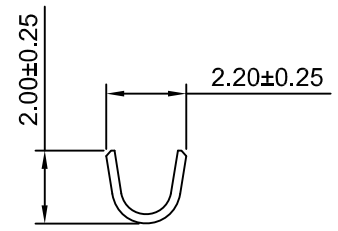

SEC:B-B

Ordering information & Specifications



Unit:mm

Part No	Wire Range	Insulation O.D.	Material	Finish	Qty/reel
HDGC4501M-TP-L	AWG#20-#26	2.50mm(max)	Phosphor Bronze	Tin over Nickel	4,000 PCS
HDGC4501M-GP-L	AWG#20-#26	2.50mm(max)	Phosphor Bronze	Gold over Nickel	4,000 PCS

Optional Gold plating available but MOQ requested



**深圳市华德共创科技有限公司**  
 SHENZHEN HUADE CO-CREATE TECHNOLOGY CO.,LTD  
 TEL : 0755-27129737 FAX : 0755-29940187

-TOLERANCES- UNLESS OTHERWISE SPECIFIED 公差参数表			 	TITLE: 4.50mm Pitch 产品名称: Crimp Terminal							
X.X	±0.30	X.X°	±3°	APPD: 核准:	XIE			PART NO: 产品编号:	HDGC4501M-T-L		
X.XX	±0.30	X.XX°	±2°	CHECK: 校对:	WANG			DATE	SCALE	UNIT	CODE NUMBER
X.XXX	±0.10	X.XXX°	±1°	DRAW: 绘图:	WANG			2012-04-16	5:1	mm	A008

修订 REV	标记 MARK	修改摘要 REVISION DESCRIPTION	签名 SIGNATURE	日期 DATE
AO		NEW RELEASE	WANG	2015-05-22

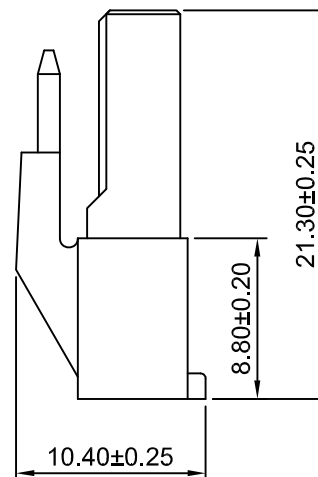
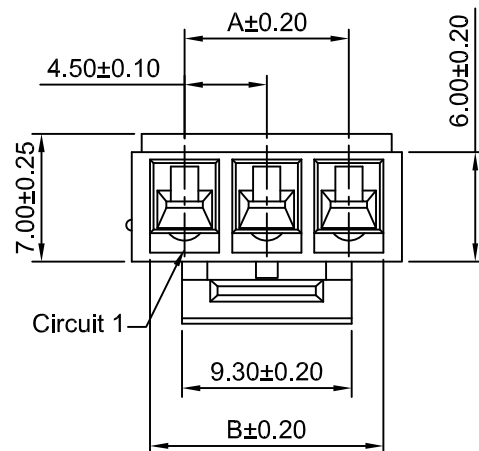
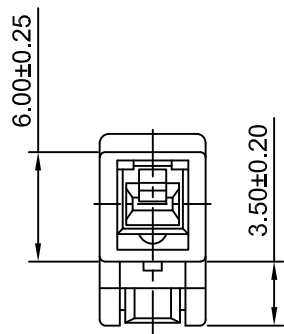

**Ordering Information:**

HDGC4501HF-XP - \*\*  
1 2

- 1.Part No.
- 2.Material:  
(blank):UL94V-0/White  
V2:UL94V-2/Natural

**SPECIFICATIONS:**

Current Rating: 10A AC,DC  
Voltage Rating: 300V AC,DC  
Temperature Range: -25°C ~ +85°C  
Contact Resistance: 7mΩ Max  
Insulation Resistance: 1000MΩ Min  
Withstanding Voltage: 1500V AC/minute  
Material: Nylon 66,UL94V-0(White)

**Ordering Information & Dimensions**

Circuits	Dimensions(mm)			Circuits	Dimensions(mm)		
	A	B	C		A	B	C
1P	---	3.80	5.80	3P	9.00	12.80	14.80
2P	4.50	8.30	10.30				

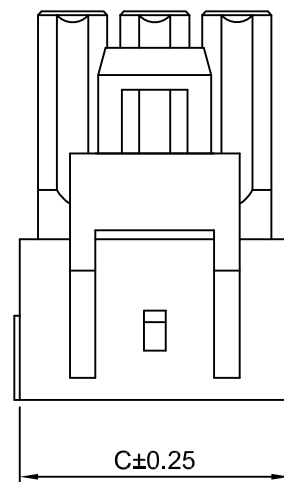
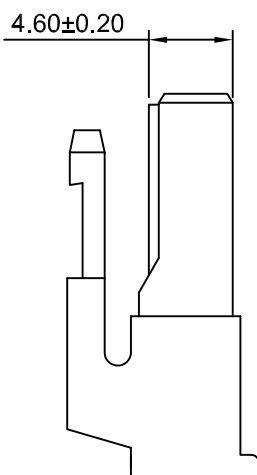
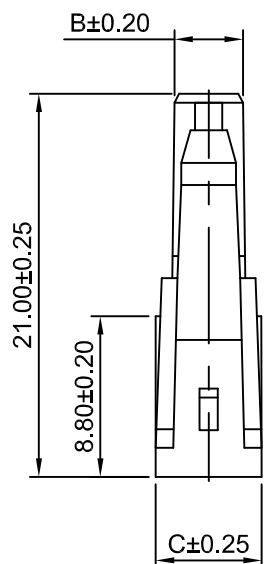

1P

2P~3P



**深圳市华德共创科技有限公司**

SHENZHEN HUADE CO-CREATE TECHNOLOGY CO.,LTD

TEL : 0755-27129737 FAX : 0755-29940187

-TOLERANCES- UNLESS OTHERWISE SPECIFIED 公差参数表						TITLE: 4.50mm Pitch Housing 产品名称:			
X.X	±0.30	X.X°	±3°	APPD: 核准:	XIE	PART NO: 产品编号: HDGC4501HF-XP			
X.XX	±0.30	X.XX°	±2°	CHECK: 校对:	WANG	DATE	SCALE	UNIT	CODE NUMBER
X.XXX	±0.10	X.XXX°	±1°	DRAW: 绘图:	WANG	2015-05-22	2.5:1	mm	A008

修订 REV	标记 MARK	修改摘要 REVISION DESCRIPTION	签名 SIGNATURE	日期 DATE
AO		NEW RELEASE	WANG	2015-05-22

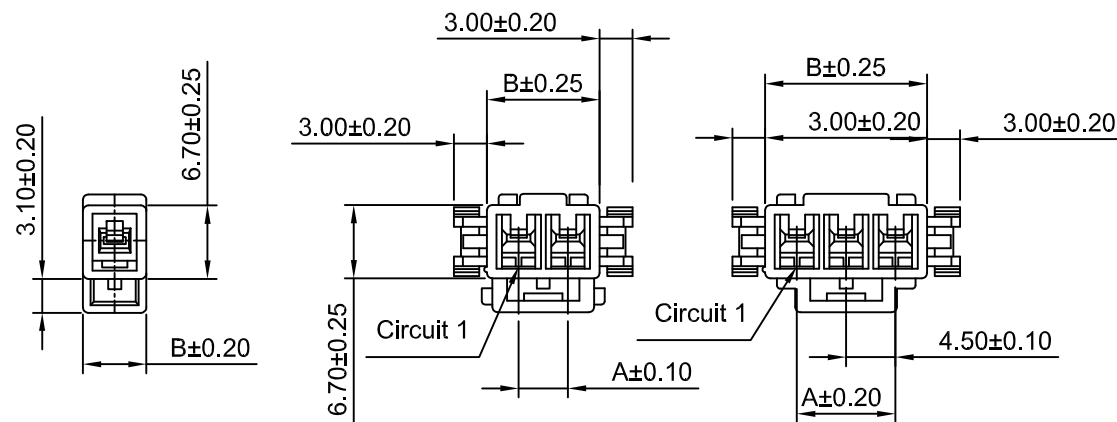

**Ordering Information:**

HDGC4501HM-XP - \*\*  
1 2

1.Part No.

2.Material:

(blank):UL94V-0/White  
V2:UL94V-2/Natural

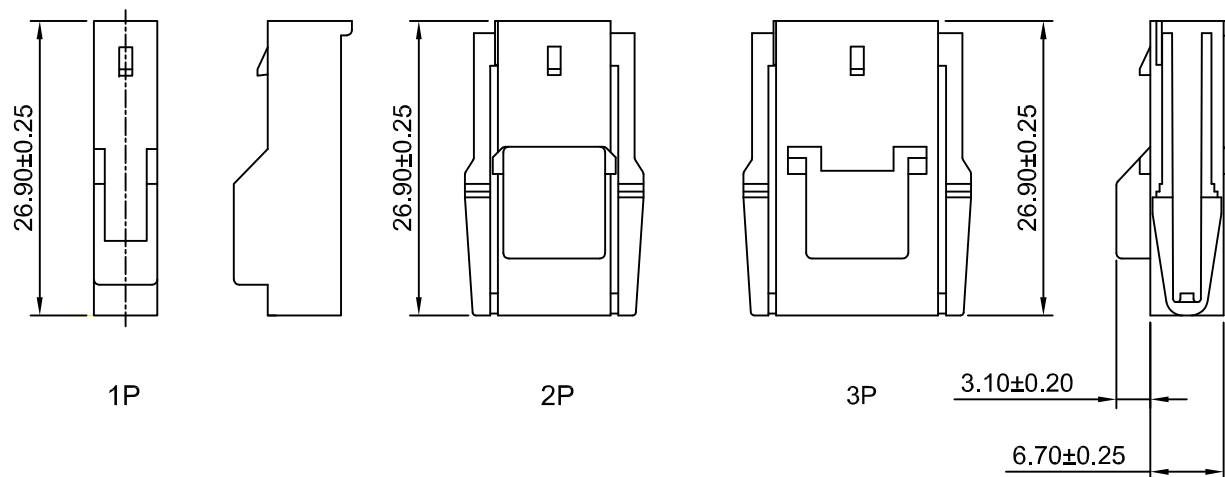

**SPECIFICATIONS:**

Current Rating: 10A AC,DC  
Voltage Rating: 300V AC,DC  
Temperature Range:-25°C ~ +85°C  
Contact Resistance: 7mΩ Max  
Insulation Resistance: 1000MΩ Min  
Withstanding Voltage: 1500V AC/minute  
Material: Nylon 66,UL94V-0(White)

**Ordering Information & Dimensions**

Circuits	Dimensions(mm)		Circuits	Dimensions(mm)	
	A	B		A	B
1P	---	5.80	3P	9.00	14.80
2P	4.50	10.30			



**深圳市华德共创科技有限公司**

SHENZHEN HUADE CO-CREATE TECHNOLOGY CO.,LTD

TEL : 0755-27129737 FAX : 0755-29940187

-TOLERANCES- UNLESS OTHERWISE SPECIFIED 公差参数表						TITLE: 4.50mm Pitch Housing 产品名称: 4.50mm Pitch Housing			
X.X	±0.30	X.X°	±3°	APPD: 核准:	XIE	PART NO: 产品编号: HDGC4501HM-XP			
X.XX	±0.30	X.XX°	±2°	CHECK: 校对:	WANG	DATE	SCALE	UNIT	CODE NUMBER
X.XXX	±0.10	X.XXX°	±1°	DRAW: 绘图:	WANG	2015-05-22	1.5:1	mm	A008

修订 REV	标记 MARK	修改摘要 REVISION DESCRIPTION	签名 SIGNATURE	日期 DATE
AO		NEW RELEASE	WANG	2015-05-22

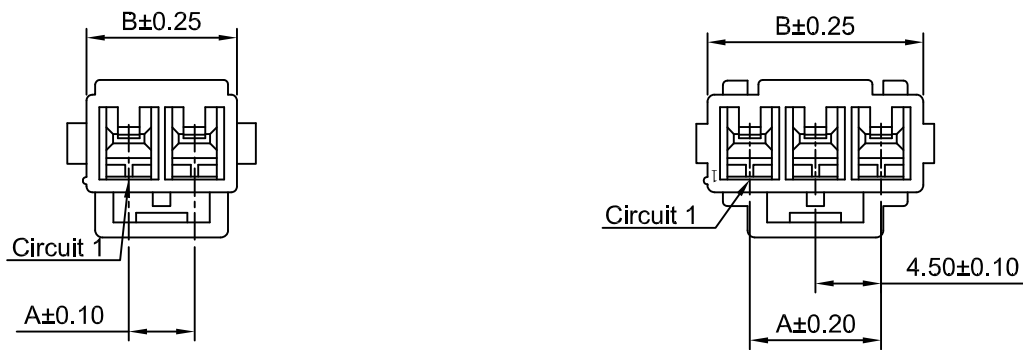

**Ordering Information:**

HDGC4501HMA-XP - \*\*  
1 2

1.Part No.

2.Material:

(blank):UL94V-0/White

V2:UL94V-2/Natural

**SPECIFICATIONS:**

Current Rating: 10A AC,DC

Voltage Rating: 300V AC,DC

Temperature Range: -25°C ~ +85°C

Contact Resistance: 7mΩ Max

Insulation Resistance: 1000MΩ Min

Withstanding Voltage: 1500V AC/minute

Material: Nylon 66,UL94V-0(White)

**Ordering Information & Dimensions**

Circuits	Dimensions(mm)		Circuits	Dimensions(mm)	
	A	B		A	B
2P	4.50	10.30	3P	9.00	14.80

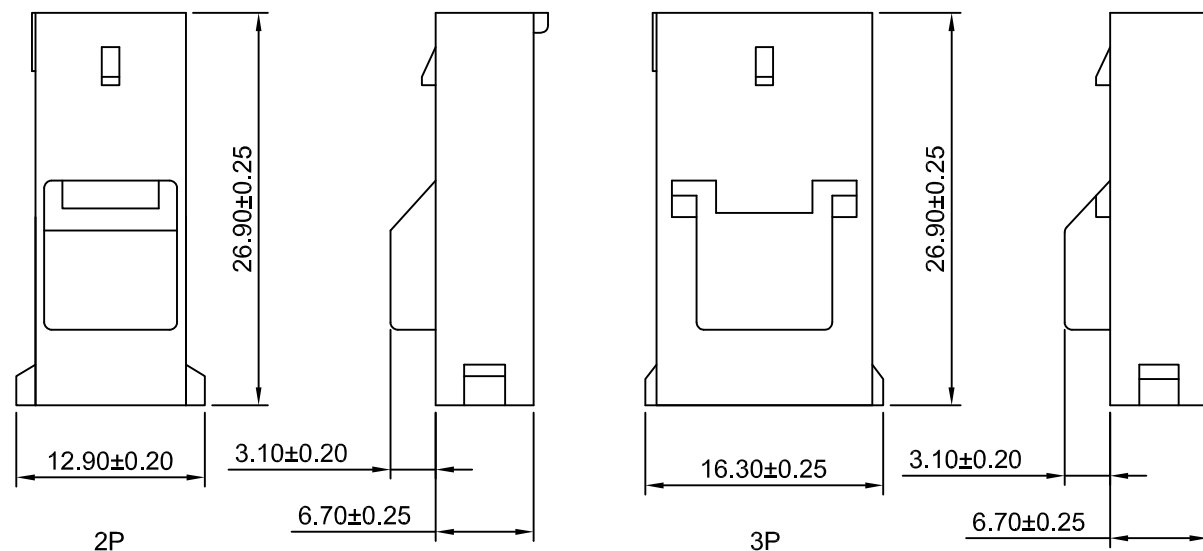

**深圳市华德共创科技有限公司**

SHENZHEN HUADE CO-CREATE TECHNOLOGY CO.,LTD

TEL : 0755-27129737 FAX : 0755-29940187

-TOLERANCES- UNLESS OTHERWISE SPECIFIED 公差参数表				TITLE: 产品名称: 4.50mm Pitch Housing	
X.X	±0.30	X.X°	±3°	APPD: 核准:	XIE
X.XX	±0.30	X.XX°	±2°	CHECK: 校对:	WANG
X.XXX	±0.10	X.XXX°	±1°	DRAW: 绘图:	WANG
PART NO: 产品编号:		HDGC4501HMA-XP			
DATE	SCALE	UNIT	CODE NUMBER		
2015-05-22	2:1	mm	A008		

修订 REV	标记 MARK	修改摘要 REVISION DESCRIPTION	签名 SIGNATURE	日期 DATE
AO		NEW RELEASE	WANG	2015-05-22

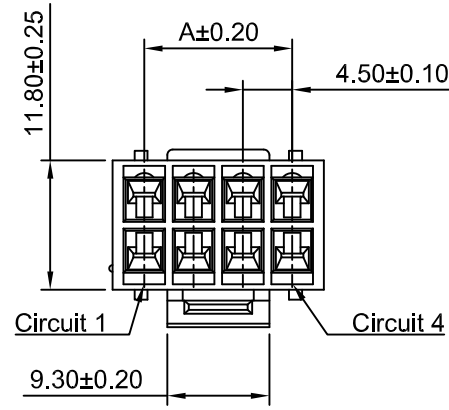
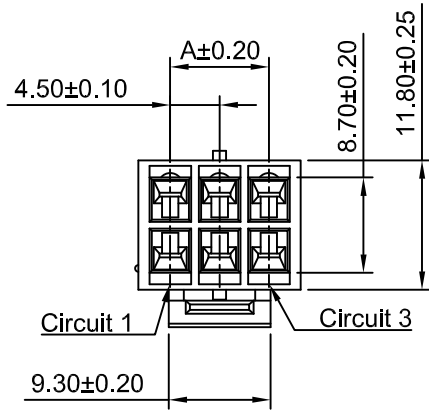

**Ordering Information:**

HDGC4501HF-2xXP - \*\*  
1 2

1.Part No.

2.Material:

(blank):UL94V-0/White

V2:UL94V-2/Natural

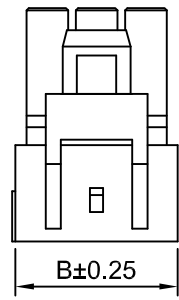

2x2P~2x3P

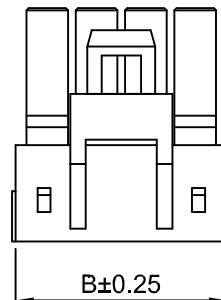
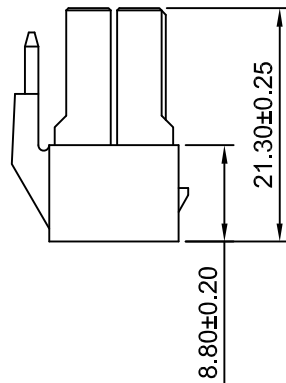

2x4P~2x6P

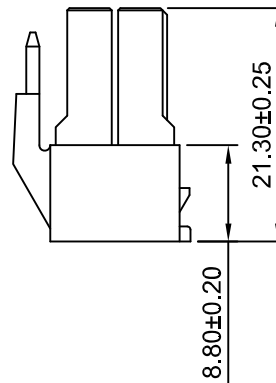

**SPECIFICATIONS:**

Current Rating: 10A AC,DC

Voltage Rating: 300V AC,DC

Temperature Range:-25°C ~ +85°C

Contact Resistance: 7mΩ Max

Insulation Resistance: 1000MΩ Min

Withstanding Voltage: 1500V AC/minute

Material: Nylon 66,UL94V-0(White)

**Ordering Information & Dimensions**

Circuits	Dimensions(mm)		Circuits	Dimensions(mm)	
	A	B		A	B
2x2P	4.50	10.30	2x4P	13.50	19.30
2x3P	9.00	14.80	2x6P	22.50	28.30



深圳市华德共创科技有限公司

SHENZHEN HUADE CO-CREATE TECHNOLOGY CO.,LTD

TEL : 0755-27129737 FAX : 0755-29940187

-TOLERANCES- UNLESS OTHERWISE SPECIFIED 公差参数表						TITLE: 产品名称: 4.50mm Pitch Housing			
X.X	±0.30	X.X°	±3°	APPD: 核准:	XIE	PART NO: 产品编号: HDGC4501HF-2xXP			
X.XX	±0.30	X.XX°	±2°	CHECK: 校对:	WANG	DATE	SCALE	UNIT	CODE NUMBER
X.XXX	±0.10	X.XXX°	±1°	DRAW: 绘图:	WANG	2015-05-22	1.5:1	mm	A008

修订 REV	标记 MARK	修改摘要 REVISION DESCRIPTION	签名 SIGNATURE	日期 DATE
AO		NEW RELEASE	WANG	2015-05-22

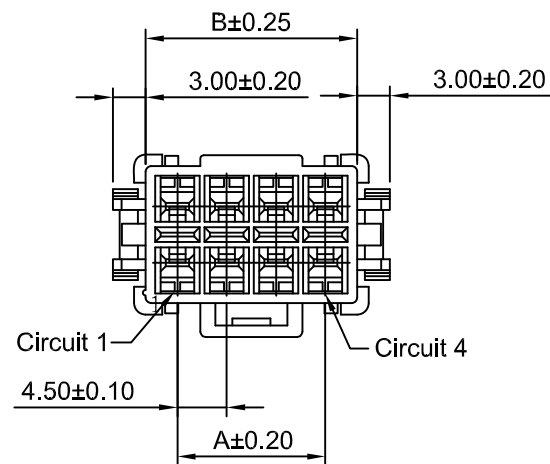
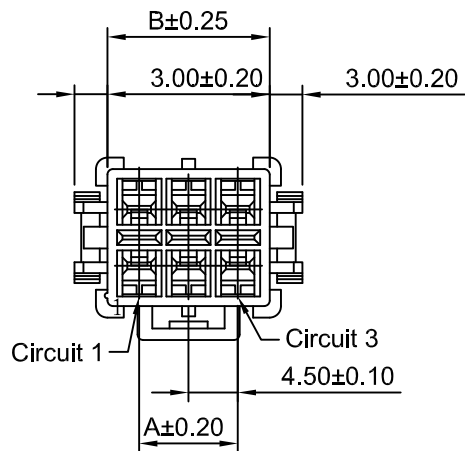

**Ordering Information:**  
 HDGC4501HM-2xXP - \*\*  
 1 2

- 1.Part No.
- 2.Material:  
 (blank):UL94V-0/White  
 V2:UL94V-2/Natural

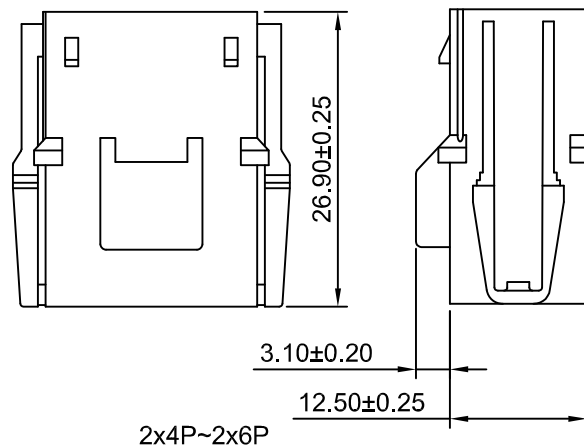
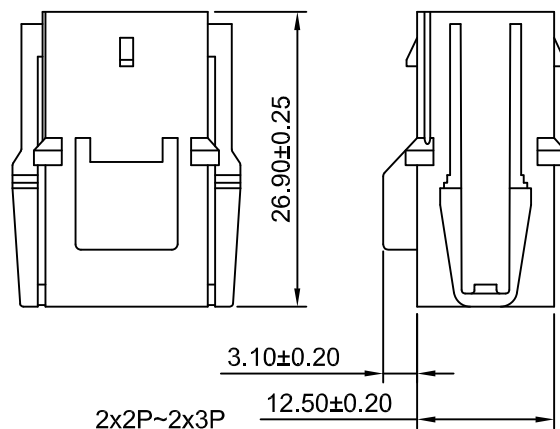

**SPECIFICATIONS:**

Current Rating: 10A AC,DC  
 Voltage Rating: 300V AC,DC  
 Temperature Range:-25°C ~ +85°C  
 Contact Resistance: 7mΩ Max  
 Insulation Resistance: 1000MΩ Min  
 Withstanding Voltage: 1500V AC/minute  
 Material: Nylon 66,UL94V-0(White)

**Ordering Information & Dimensions**

Circuits	Dimensions(mm)		Circuits	Dimensions(mm)	
	A	B		A	B
2x2P	4.50	10.30	2x4P	13.50	19.30
2x3P	9.00	14.80	2x6P	22.50	28.30



深圳市华德共创科技有限公司

SHENZHEN HUADE CO-CREATE TECHNOLOGY CO.,LTD

TEL : 0755-27129737 FAX : 0755-29940187

-TOLERANCES- UNLESS OTHERWISE SPECIFIED 公差参数表					TITLE: 4.50mm Pitch Housing 产品名称:			
X.X	±0.30	X.X° ±3°	APPD: 核准:	XIE	PART NO: 产品编号: HDGC4501HM-2xXP			
X.XX	±0.30	X.XX° ±2°	CHECK: 校对:	WANG	DATE	SCALE	UNIT	CODE NUMBER
X.XXX	±0.10	X.XXX° ±1°	DRAW: 绘图:	WANG	2015-05-22	1.5:1	mm	A008

修订 REV	标记 MARK	修改摘要 REVISION DESCRIPTION	签名 SIGNATURE	日期 DATE
AO		NEW RELEASE	WANG	2015-05-22

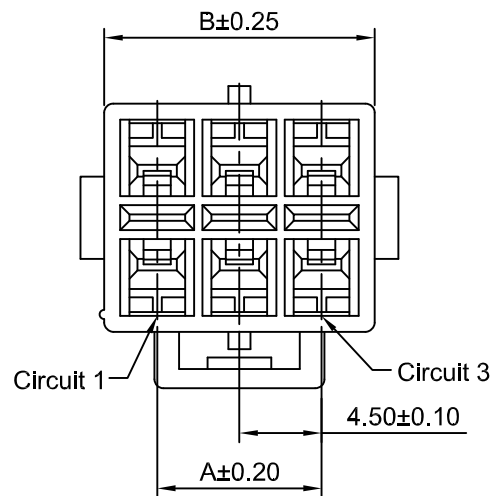

**Ordering Information:**

HDGC4501HMA-2xXP - \*\*  
1 2

- 1.Part No.
- 2.Material:  
(blank):UL94V-0/White  
V2:UL94V-2/Natural

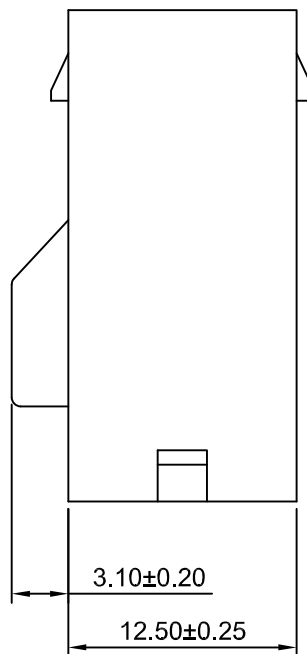
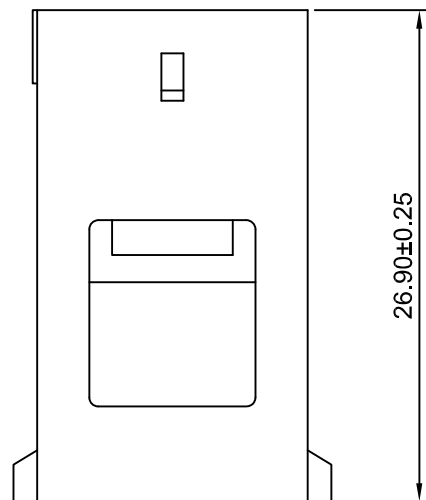

**SPECIFICATIONS:**

- Current Rating: 10A AC,DC
- Voltage Rating: 300V AC,DC
- Temperature Range: -25°C ~ +85°C
- Contact Resistance: 7mΩ Max
- Insulation Resistance: 1000MΩ Min
- Withstanding Voltage: 1500V AC/minute
- Material: Nylon 66,UL94V-0(White)

**Ordering Information & Dimensions**

Circuits	Dimensions(mm)		Circuits	Dimensions(mm)	
	A	B		A	B
2x2P	4.50	10.30	2x3P	9.00	14.80



**深圳市华德共创科技有限公司**

SHENZHEN HUADE CO-CREATE TECHNOLOGY CO.,LTD

TEL : 0755-27129737 FAX : 0755-29940187

-TOLERANCES- UNLESS OTHERWISE SPECIFIED 公差参数表						TITLE: 4.50mm Pitch 产品名称: Housing			
X.X	±0.30	X.X°	±3°	APPD: 核准:	XIE	PART NO: 产品编号: HDGC4501HMA-2xXP			
X.XX	±0.30	X.XX°	±2°	CHECK: 校对:	WANG	DATE	SCALE	UNIT	CODE NUMBER
X.XXX	±0.10	X.XXX°	±1°	DRAW: 绘图:	WANG	2015-05-22	2.5:1	mm	A008

修订 REV	标记 MARK	修改摘要 REVISION DESCRIPTION	签名 SIGNATURE	日期 DATE
AO		NEW RELEASE	WANG	2015-05-22

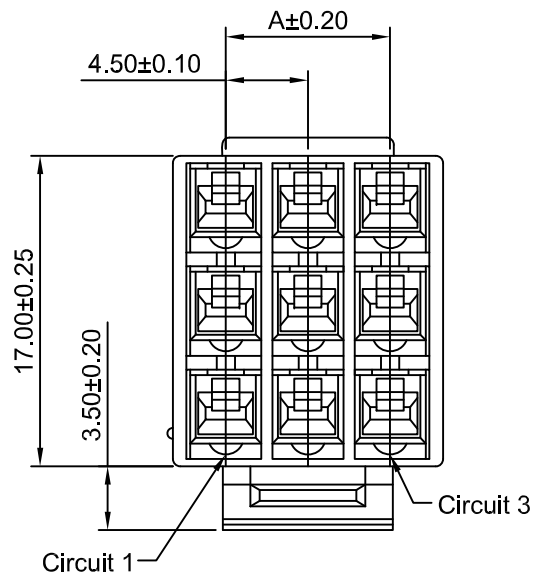

Ordering Information:  
 HDGC4501HF-3xXP - \*\*  
 1 2

- Part No.
- Material:  
 (blank):UL94V-0/White  
 V2:UL94V-2/Natural

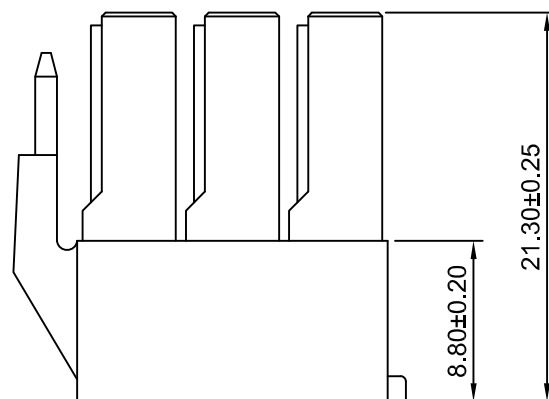
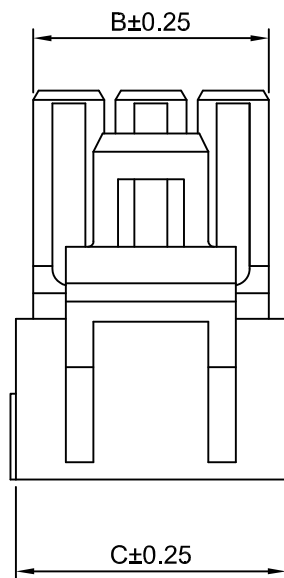

**SPECIFICATIONS:**

Current Rating: 10A AC,DC  
 Voltage Rating: 300V AC,DC  
 Temperature Range: -25°C ~ +85°C  
 Contact Resistance: 7mΩ Max  
 Insulation Resistance: 1000MΩ Min  
 Withstanding Voltage: 1500V AC/minute  
 Material: Nylon 66,UL94V-0(White)

**Ordering Information & Dimensions**

Circuits	Dimensions(mm)			Circuits	Dimensions(mm)		
	A	B	C		A	B	C
3x3P	9.00	12.90	14.80	3x5P	18.00	21.90	23.80
3x4P	13.50	17.40	19.30				



深圳市华德共创科技有限公司

SHENZHEN HUADE CO-CREATE TECHNOLOGY CO.,LTD

TEL : 0755-27129737 FAX : 0755-29940187

-TOLERANCES- UNLESS OTHERWISE SPECIFIED 公差参数表						TITLE: 4.50mm Pitch Housing 产品名称:			
X.X	±0.30	X.X°	±3°	APPD: 核准:	XIE	PART NO: 产品编号: HDGC4501HF-3xXP			
X.XX	±0.30	X.XX°	±2°	CHECK: 校对:	WANG	DATE	SCALE	UNIT	CODE NUMBER
X.XXX	±0.10	X.XXX°	±1°	DRAW: 绘图:	WANG	2015-05-22	2.5:1	mm	A008

修订 REV	标记 MARK	修改摘要 REVISION DESCRIPTION	签名 SIGNATURE	日期 DATE
AO		NEW RELEASE	WANG	2015-05-22

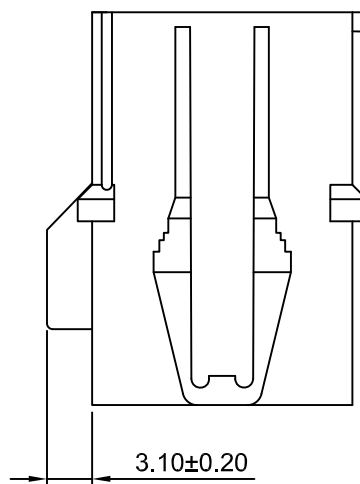
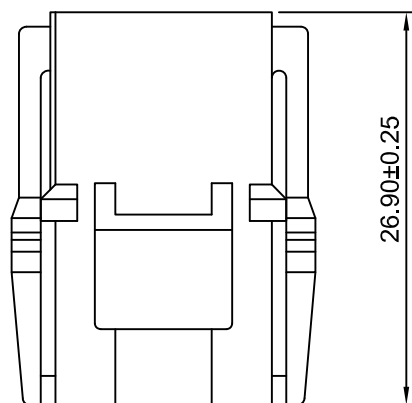
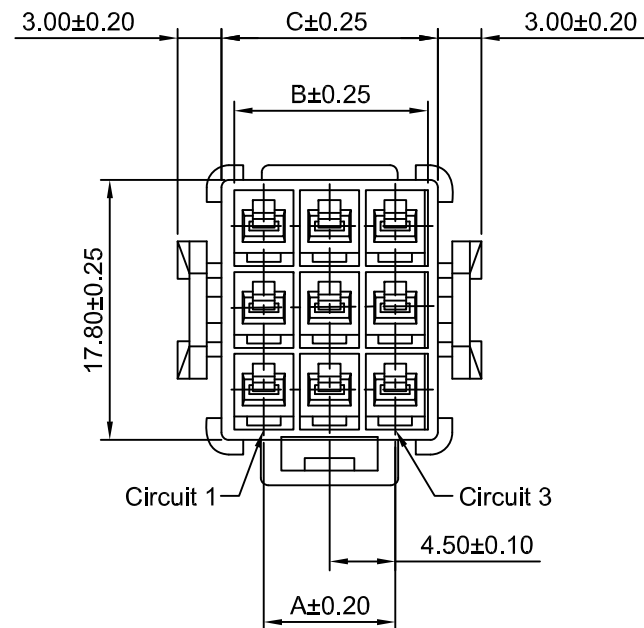

Ordering Information:  
**HDGC4501HM-3xXP - \*\***  
 1 2

- 1.Part No.
- 2.Material:  
 (blank):UL94V-0/White  
 V2:UL94V-2/Natural

**SPECIFICATIONS:**

Current Rating: 10A AC,DC  
 Voltage Rating: 300V AC,DC  
 Temperature Range: -25°C ~ +85°C  
 Contact Resistance: 7mΩ Max  
 Insulation Resistance: 1000MΩ Min  
 Withstanding Voltage: 1500V AC/minute  
 Material: Nylon 66,UL94V-0(White)

Ordering Information & Dimensions

Circuits	Dimensions(mm)			Circuits	Dimensions(mm)		
	A	B	C		A	B	C
3x3P	9,00	13,25	14,80	3x5P	18,00	22,25	23,80
3x4P	13,50	17,75	19,30				



深圳市华德共创科技有限公司

SHENZHEN HUADE CO-CREATE TECHNOLOGY CO.,LTD

TEL : 0755-27129737 FAX : 0755-29940187

-TOLERANCES- UNLESS OTHERWISE SPECIFIED 公差参数表						TITLE: 产品名称 : 4.50mm Pitch Housing			
X.X	±0.30	X.X°	±3°	APPD: 核准 :	XIE	PART NO: 产品编号 : HDGC4501HM-3xXP			
X.XX	±0.30	X.XX°	±2°	CHECK: 校对 :	WANG	DATE	SCALE	UNIT	CODE NUMBER
X.XXX	±0.10	X.XXX°	±1°	DRAW: 绘图 :	WANG	2015-05-22	2:1	mm	A008

修订 REV	标记 MARK	修改摘要 REVISION DESCRIPTION	签名 SIGNATURE	日期 DATE
AO		NEW RELEASE	WANG	2015-05-22

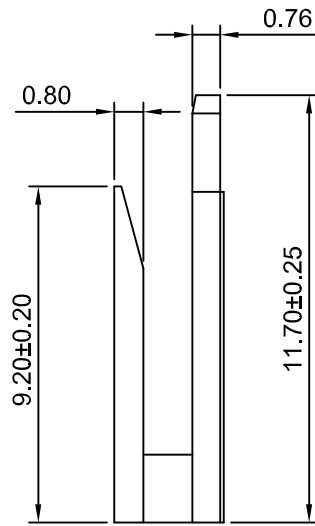
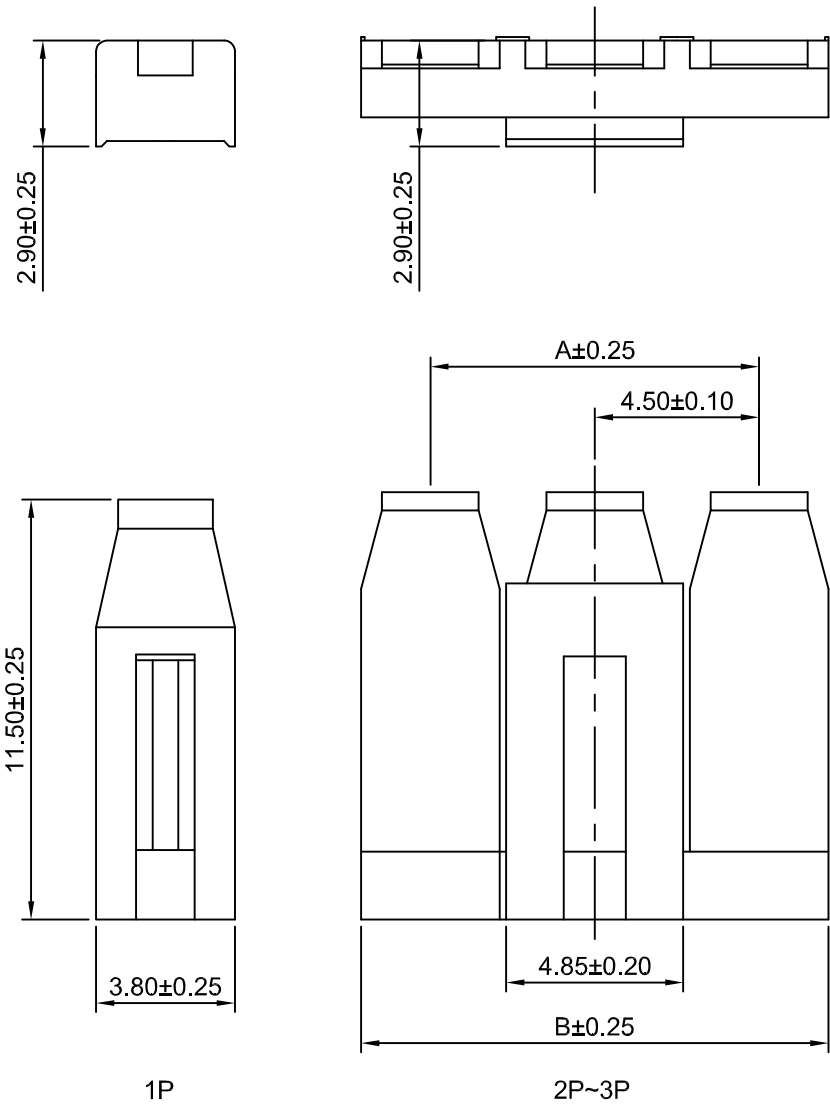

**SPECIFICATIONS:**  
 Current Rating: 10A AC,DC  
 Voltage Rating: 300V AC,DC  
 Temperature Range: -25°C ~ +85°C  
 Contact Resistance: 7mΩ Max  
 Insulation Resistance: 1000MΩ Min  
 Withstanding Voltage: 1500V AC/minute  
 Material: Nylon 66,UL94V-0(Ivory)

**Ordering Information & Dimensions**

Circuits	Dimensions(mm)		Circuits	Dimensions(mm)	
	A	B		A	B
1P	---	3.80	3P	9.00	12.80
2P	4.50	8.30			

**HDGC** 深圳市华德共创科技有限公司  
 SHENZHEN HUADE CO-CREATE TECHNOLOGY CO.,LTD  
 TEL : 0755-27129737 FAX : 0755-29940187

-TOLERANCES- UNLESS OTHERWISE SPECIFIED 公差参数表						TITLE: 4.50mm Pitch 产品名称: Wire Seal			
X.X	±0.30	X.X°	±3°	APPD: 核准:	XIE	PART NO: 产品编号: HDGC4501S-XP			
X.XX	±0.30	X.XX°	±2°	CHECK: 校对:	WANG	DATE	SCALE	UNIT	CODE NUMBER
X.XXX	±0.10	X.XXX°	±1°	DRAW: 绘图:	WANG	2015-05-22	5:1	mm	A008