

修订 REV	标记 MARK	修改摘要 REVISION DESCRIPTION	签名 SIGNATURE	日期 DATE
AO		NEW RELEASE	WANG	2013-12-06

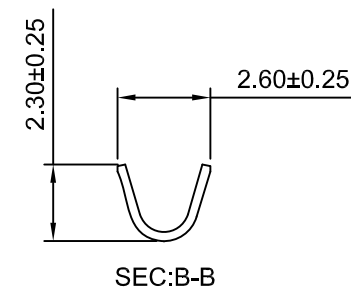
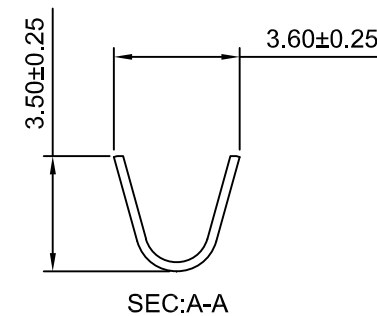
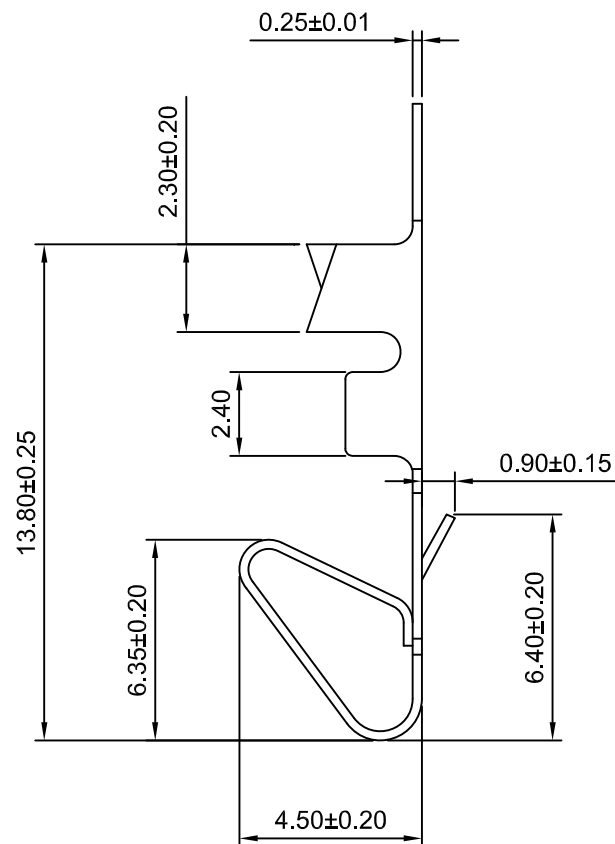
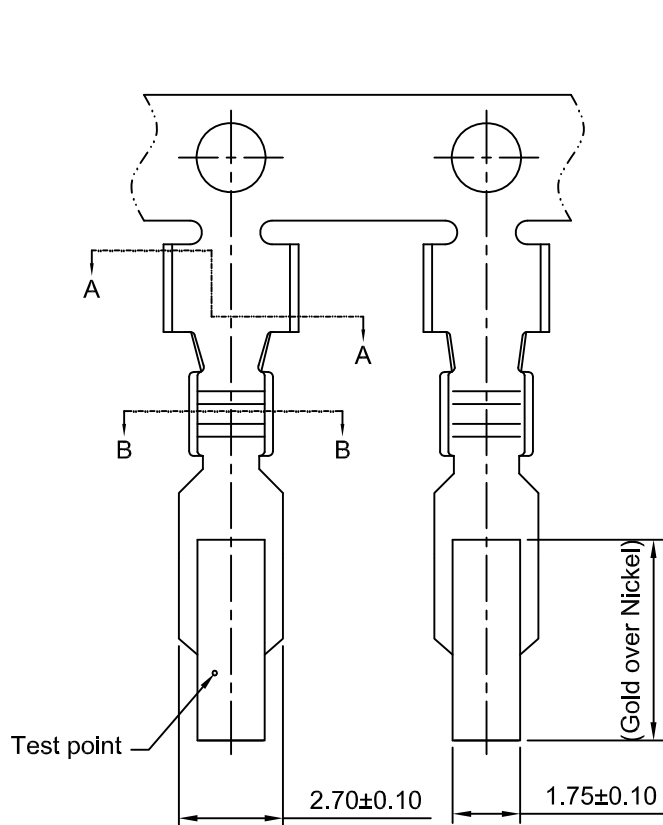

Ordering information & Specifications

Unit:mm

Part No	Wire Range	Insulation O.D.	Material	Finish	Qty/reel
HDGC3961-TB	AWG#18-#24	2.80mm(max)	Brass	Tin over Nickel	6,000 PCS
HDGC3961-TP	AWG#18-#24	2.80mm(max)	Phosphor Bronze	Tin over Nickel	6,000 PCS
HDGC3961-GB	AWG#18-#24	2.80mm(max)	Brass	Gold over Nickel	6,000 PCS
HDGC3961-GP	AWG#18-#24	2.80mm(max)	Phosphor Bronze	Gold over Nickel	6,000 PCS

Optional Gold plating available but MOQ requested



深圳市华德共创科技有限公司

SHENZHEN HUADE CO-CREATE TECHNOLOGY CO.,LTD

TEL : 0755-27129737 FAX : 0755-29940187

-TOLERANCES- UNLESS OTHERWISE SPECIFIED 公差参数表					TITLE: 3.96mm Pitch 产品名称: Crimp Terminal				
X.X	±0.30	X.X°	±3°	APPD: 核准:	XIE				
X.XX	±0.30	X.XX°	±2°	CHECK: 校对:	WANG	DATE	SCALE	UNIT	CODE NUMBER
X.XXX	±0.10	X.XXX°	±1°	DRAW: 绘图:	WANG	2013-12-06	5:1	mm	A008

PART NO: HDGC3961-T
产品编号:

修订 REV	标记 MARK	修改摘要 REVISION DESCRIPTION	签名 SIGNATURE	日期 DATE
AO		NEW RELEASE	WANG	2013-12-06

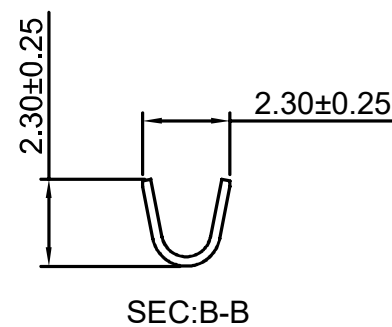
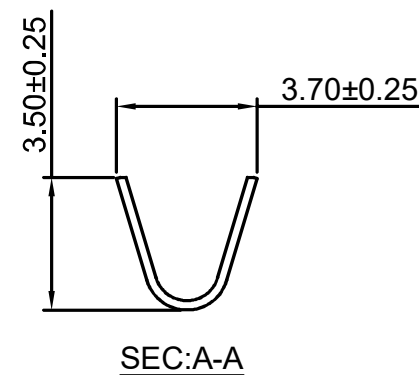
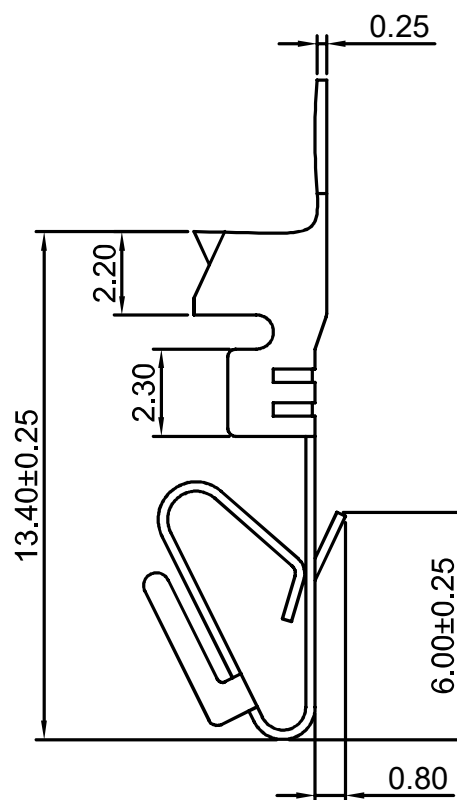
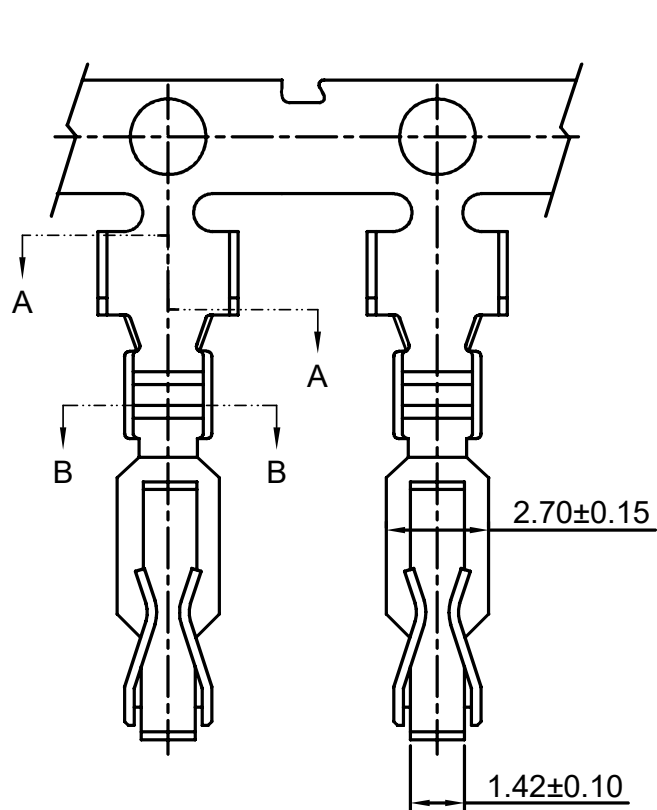

Ordering information & Specifications

Unit:mm

Part No	Wire Range	Insultion O.D.	Material	Finish	Qty/reel
HDGC3961-TB-1	AWG#18-#24	2.80mm(max)	Brass	Tin over Nickel	6,000 PCS
HDGC3961-TP-1	AWG#18-#24	2.80mm(max)	Phosphor Bronze	Tin over Nickel	6,000 PCS
HDGC3961-GB-1	AWG#18-#24	2.80mm(max)	Brass	Gold over Nickel	6,000 PCS
HDGC3961-GP-1	AWG#18-#24	2.80mm(max)	Phosphor Bronze	Gold over Nickel	6,000 PCS

Optional Gold plating available but MOQ requested



深圳市华德共创科技有限公司

SHENZHEN HUADE CO-CREATE TECHNOLOGY CO.,LTD

TEL : 0755-27129737 FAX : 0755-29940187

-TOLERANCES- UNLESS OTHERWISE SPECIFIED 公差参数表					TITLE: 3.96mm Pitch 产品名称: Crimp Terminal			
X.X	±0.30	X.X°	±3°	APPD: 核准: XIE	PART NO: 产品编号: HDGC3961-T-1			
X.XX	±0.30	X.XX°	±2°	CHECK: 校对: WANG	DATE	SCALE	UNIT	CODE NUMBER
X.XXX	±0.10	X.XXX°	±1°	DRAW: 绘图: WANG	2013-12-06	5:1	mm	A008

修订 REV	标记 MARK	修改摘要 REVISION DESCRIPTION	签名 SIGNATURE	日期 DATE
AO		NEW RELEASE	WANG	2013-12-06

Ordering Information:
 HDGC3961H-XP - * - **
 1 2 3

1.Part No.

2.Style:

(blank) - Type 1

2 - Type 2

3 - Type 3

3.Material

(blank) - UL94V-2/Natural

V0 - UL94V-0/White

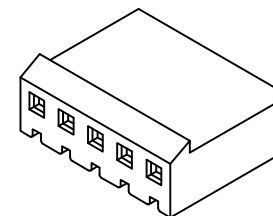

SPECIFICATIONS:

Current Rating: 7A AC,DC

Voltage Rating: 250V AC,DC

Temperature Range: -25°C ~ +85°C

Contact Resistance: 10mΩ Max

Insulation Resistance: 1000MΩ Min

Withstanding Voltage: 1500V AC/minute

Material: Nylon 66,UL94V-2 or UL94V-0

Ordering Information & Dimensions

Circuits	Dimensions(mm)		Circuits	Dimensions(mm)	
	A	B		A	B
2P	3.96	8.43	14P	51.48	55.95
3P	7.92	12.39	15P	55.44	59.91
4P	11.88	16.35	16P	59.40	63.87
5P	15.84	20.31	17P	63.36	67.83
6P	19.80	24.27	18P	67.32	71.79
7P	23.76	28.23	19P	71.28	75.75
8P	27.72	32.19	20P	75.24	79.71
9P	31.68	36.15	21P	79.20	83.67
10P	35.64	40.11	22P	83.16	87.63
11P	39.60	44.07	23P	87.12	91.59
12P	43.56	48.03	24P	91.08	95.55
13P	47.52	51.99			

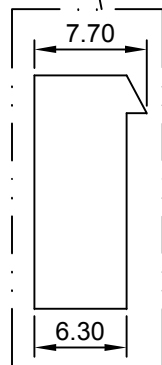
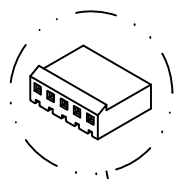
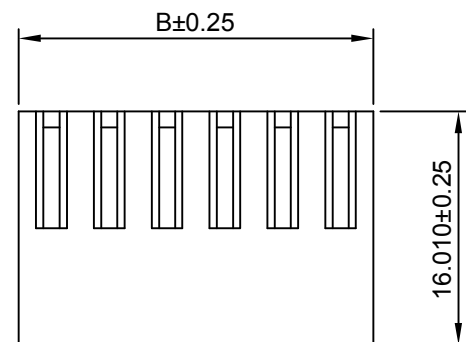
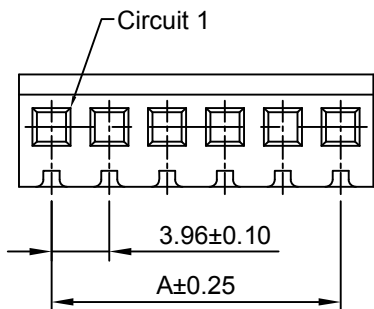

TYPE 1

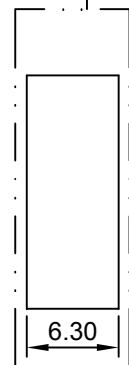
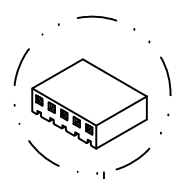

TYPE 2

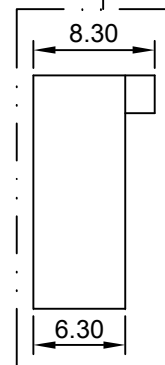
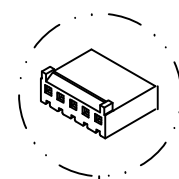

TYPE 3



深圳市华德共创科技有限公司

SHENZHEN HUADE CO-CREATE TECHNOLOGY CO.,LTD

TEL : 0755-27129737 FAX : 0755-29940187

-TOLERANCES- UNLESS OTHERWISE SPECIFIED 公差参数表						TITLE: 3.96mm Pitch Housing 产品名称:			
X.X	±0.30	X.X°	±3°	APPD: 核准:	XIE	PART NO: 产品编号: HDGC3961H-XP			
X.XX	±0.30	X.XX°	±2°	CHECK: 校对:	WANG	DATE	SCALE	UNIT	CODE NUMBER
X.XXX	±0.10	X.XXX°	±1°	DRAW: 绘图:	WANG	2013-12-06	2:1	mm	A008

修订 REV	标记 MARK	修改摘要 REVISION DESCRIPTION	签名 SIGNATURE	日期 DATE
AO		NEW RELEASE	WANG	2013-12-06

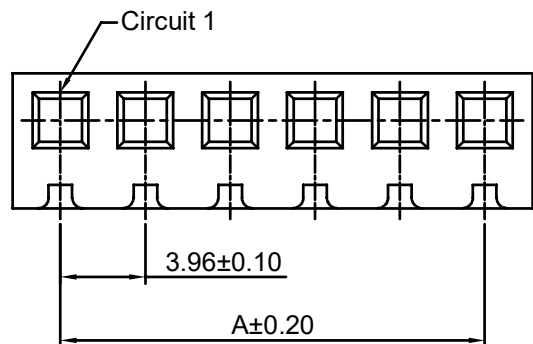

Ordering Information:
 HDGC3961H-XP-2 - * - **
 1 2 3

- Part No.
- Style:
 (blank) - Type 1
 2 - Type 2
 3 - Type 3
- Material
 (blank) - UL94V-2/Natural
 V0 - UL94V-0/White

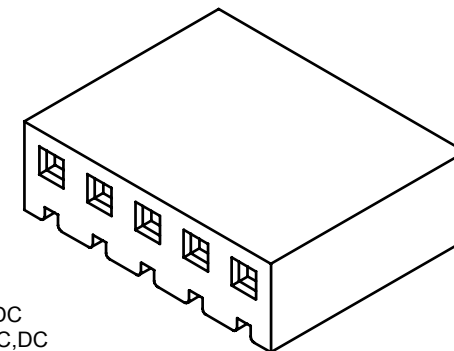

SPECIFICATIONS:

Current Rating: 7A AC,DC
 Voltage Rating: 250V AC,DC
 Temperature Range: -25°C ~ +85°C
 Contact Resistance: 10mΩ Max
 Insulation Resistance: 1000MΩ Min
 Withstanding Voltage: 1500V AC/minute
 Material: Nylon 66,UL94V-2 or UL94V-0

Ordering Information & Dimensions

Circuits	Dimensions(mm)		Circuits	Dimensions(mm)	
	A	B		A	B
2P	3.96	8.43	14P	51.48	55.95
3P	7.92	12.39	15P	55.44	59.91
4P	11.88	16.35	16P	59.40	63.87
5P	15.84	20.31	17P	63.36	67.83
6P	19.80	24.27	18P	67.32	71.79
7P	23.76	28.23	19P	71.28	75.75
8P	27.72	32.19	20P	75.24	79.71
9P	31.68	36.15	21P	79.20	83.67
10P	35.64	40.11	22P	83.16	87.63
11P	39.60	44.07	23P	87.12	91.59
12P	43.56	48.03	24P	91.08	95.55
13P	47.52	51.99			

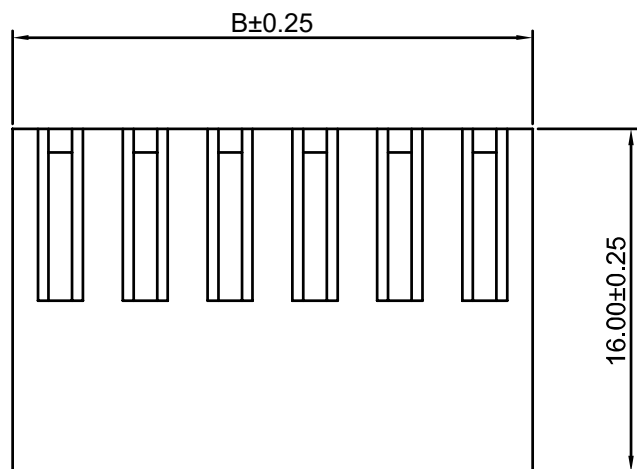



深圳市华德共创科技有限公司
 SHENZHEN HUADE CO-CREATE TECHNOLOGY CO.,LTD
 TEL : 0755-27129737 FAX : 0755-29940187

-TOLERANCES- UNLESS OTHERWISE SPECIFIED 公差参数表			 		TITLE: 3.96mm Pitch Housing 产品名称:			
X.X	±0.30	X.X°	±3°	APPD: 核准:	XIE			
X.XX	±0.30	X.XX°	±2°	CHECK: 校对:	WANG			
X.XXX	±0.10	X.XXX°	±1°	DRAW: 绘图:	WANG			
PART NO: HDGC3961H-XP-2 产品编号:					DATE	SCALE	UNIT	CODE NUMBER
					2013-12-06	3:1	mm	A008

修订 REV	标记 MARK	修改摘要 REVISION DESCRIPTION	签名 SIGNATURE	日期 DATE
AO		NEW RELEASE	WANG	2013-12-06

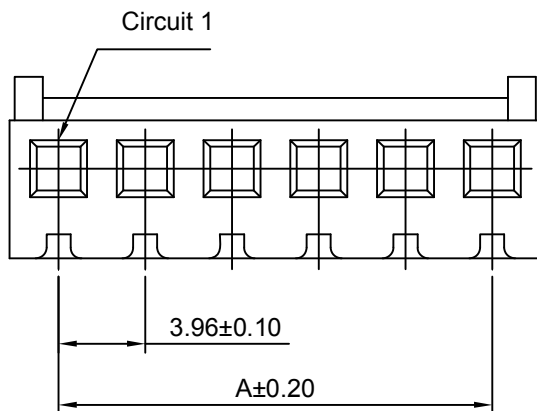

Ordering Information:
HDGC3961H-XP-3 - ^{*}/₂

- Part No.
- Material:
(blank)-UL94V-2
V0-UL94V-0

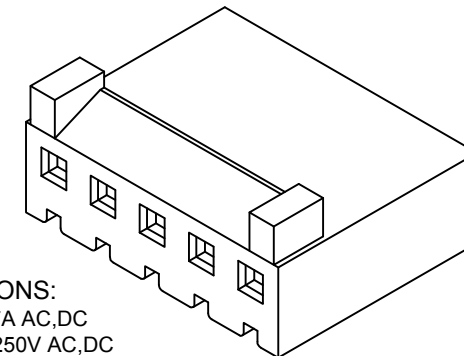

SPECIFICATIONS:
 Current Rating: 7A AC,DC
 Voltage Rating: 250V AC,DC
 Temperature Range: -25°C ~ +85°C
 Contact Resistance: 10mΩ Max
 Insulation Resistance: 1000MΩ Min
 Withstanding Voltage: 1500V AC/minute
 Material: Nylon 66,UL94V-2 or UL94V-0(Natural)

Ordering Information & Dimensions

Circuits	Dimensions(mm)		Circuits	Dimensions(mm)	
	A	B		A	B
2P	3.96	8.43	14P	51.48	55.95
3P	7.92	12.39	15P	55.44	59.91
4P	11.88	16.35	16P	59.40	63.87
5P	15.84	20.31	17P	63.36	67.83
6P	19.80	24.27	18P	67.32	71.79
7P	23.76	28.23	19P	71.28	75.75
8P	27.72	32.19	20P	75.24	79.71
9P	31.68	36.15	21P	79.20	83.67
10P	35.64	40.11	22P	83.16	87.63
11P	39.60	44.07	23P	87.12	91.59
12P	43.56	48.03	24P	91.08	95.55
13P	47.52	51.99			

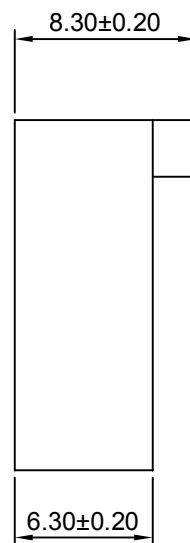
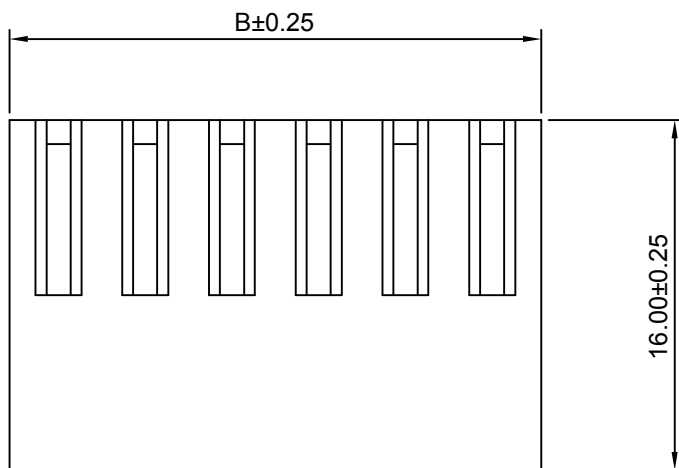



深圳市华德共创科技有限公司
 SHENZHEN HUADE CO-CREATE TECHNOLOGY CO.,LTD
 TEL : 0755-27129737 FAX : 0755-29940187

-TOLERANCES- UNLESS OTHERWISE SPECIFIED 公差参数表				 		TITLE: 3.96mm Pitch Housing 产品名称: 3.96mm Pitch Housing			
X.X	±0.30	X.X°	±3°	APPD: 核准:	XIE	PART NO: 产品编号: HDGC3961H-XP-3			
X.XX	±0.30	X.XX°	±2°	CHECK: 校对:	WANG	DATE	SCALE	UNIT	CODE NUMBER
X.XXX	±0.10	X.XXX°	±1°	DRAW: 绘图:	WANG	2013-12-06	3:1	mm	A008

修订 REV	标记 MARK	修改摘要 REVISION DESCRIPTION	签名 SIGNATURE	日期 DATE
AO		NEW RELEASE	WANG	2013-12-06

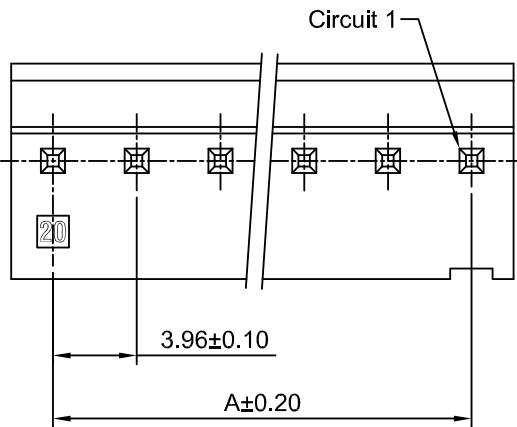

Ordering Information:

HDGC3961WV-XP - *** - ** - **

- Part No.
- Material:
(blank):Nylon 66,UL94V-2/Natural
VQ:Nylon 66,UL94V-0/White
GWT:Nylon 66,UL94V-0,GWT 750°C
- Color:
(blank):Natural/White
BL:Blue
GN:Green
RD:Red
YL:Yellow
- Finish:
(blank):Tin over Nickel
G:Gold over Nickel

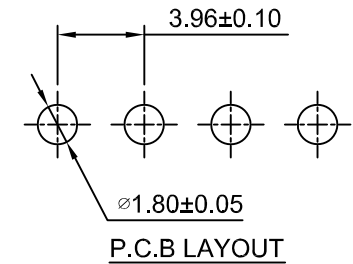
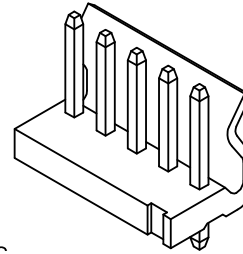

SPECIFICATIONS:

Current Rating: 7A AC,DC
Voltage Rating: 250V AC,DC
Temperature Range: -25°C ~ +85°C
Contact Resistance: 10mΩ Max
Insulation Resistance: 1000MΩ Min
Withstanding Voltage: 1500V AC/minute
Pin Material: Brass/Tin over Nickel
Material: Nylon 66,UL94V-2(Natural)

Ordering Information & Dimensions

Circuits	Dimensions(mm)		Circuits	Dimensions(mm)	
	A	B		A	B
2P	3.96	7.92	14P	51.48	55.44
3P	7.92	11.88	15P	55.44	59.40
4P	11.88	15.84	16P	59.40	63.36
5P	15.84	19.80	17P	63.36	67.32
6P	19.80	23.76	18P	67.32	71.28
7P	23.76	27.72	19P	71.28	75.24
8P	27.72	31.68	20P	75.24	79.20
9P	31.68	35.64	21P	79.20	83.16
10P	35.64	39.60	22P	83.16	87.12
11P	39.60	43.56	23P	87.12	91.08
12P	43.56	47.52	24P	91.08	95.04
13P	47.52	51.48			

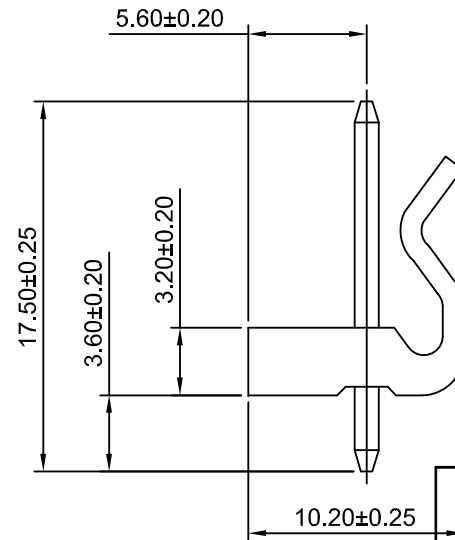
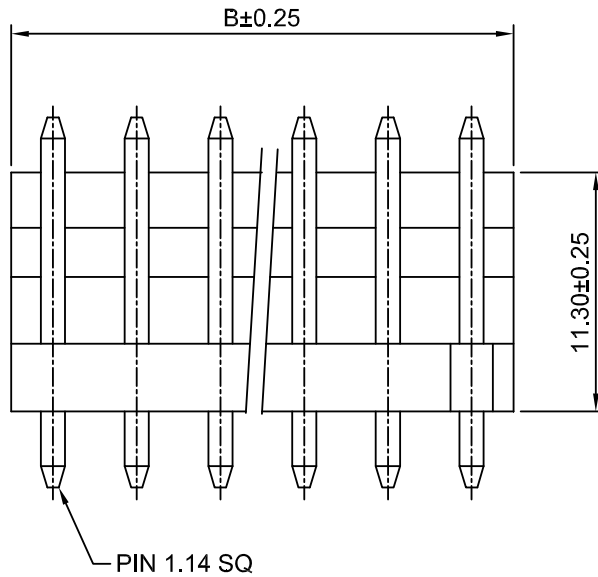

深圳市华德共创科技有限公司

SHENZHEN HUADE CO-CREATE TECHNOLOGY CO.,LTD

TEL : 0755-27129737 FAX : 0755-29940187

-TOLERANCES- UNLESS OTHERWISE SPECIFIED 公差参数表						TITLE: 3.96mm Pitch 产品名称: 180° Wafer			
X.X	±0.30	X.X°	±3°	APPD: 核准:	XIE	PART NO: 产品编号: HDGC3961WV-XP			
X.XX	±0.30	X.XX°	±2°	CHECK: 校对:	WANG	DATE	SCALE	UNIT	CODE NUMBER
X.XXX	±0.10	X.XXX°	±1°	DRAW: 绘图:	WANG	2013-12-06	3:1	mm	A008

修订 REV	标记 MARK	修改摘要 REVISION DESCRIPTION	签名 SIGNATURE	日期 DATE
AO		NEW RELEASE	WANG	2013-12-06

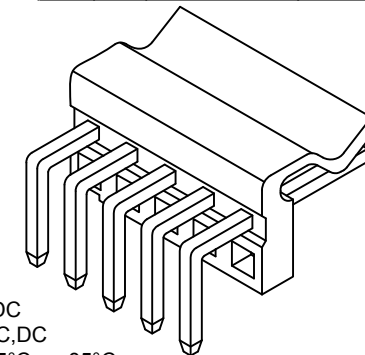

SPECIFICATIONS:

Current Rating: 7A AC,DC
Voltage Rating: 250V AC,DC
Temperature Range: -25°C ~ +85°C
Contact Resistance: 10mΩ Max
Insulation Resistance: 1000MΩ Min
Withstanding Voltage: 1500V AC/minute
Pin Material: Brass/Tin over Nickel
Material: Nylon 66,UL94V-2(Natural)

Ordering Information & Dimensions

Circuits	Dimensions(mm)		Circuits	Dimensions(mm)	
	A	B		A	B
2P	3.96	7.92	14P	51.48	55.44
3P	7.92	11.88	15P	55.44	59.40
4P	11.88	15.84	16P	59.40	63.36
5P	15.84	19.80	17P	63.36	67.32
6P	19.80	23.76	18P	67.32	71.28
7P	23.76	27.72	19P	71.28	75.24
8P	27.72	31.68	20P	75.24	79.20
9P	31.68	35.64	21P	79.20	83.16
10P	35.64	39.60	22P	83.16	87.12
11P	39.60	43.56	23P	87.12	91.08
12P	43.56	47.52	24P	91.08	95.04
13P	47.52	51.48			

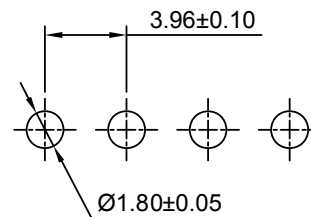
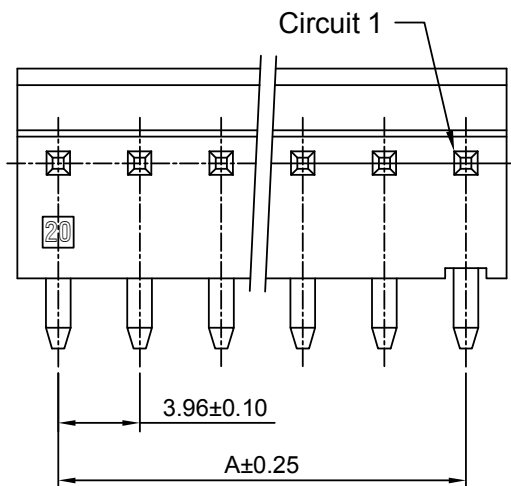

P.C.B LAYOUT

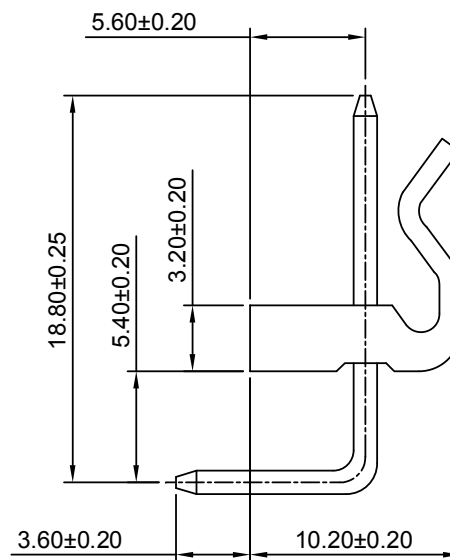
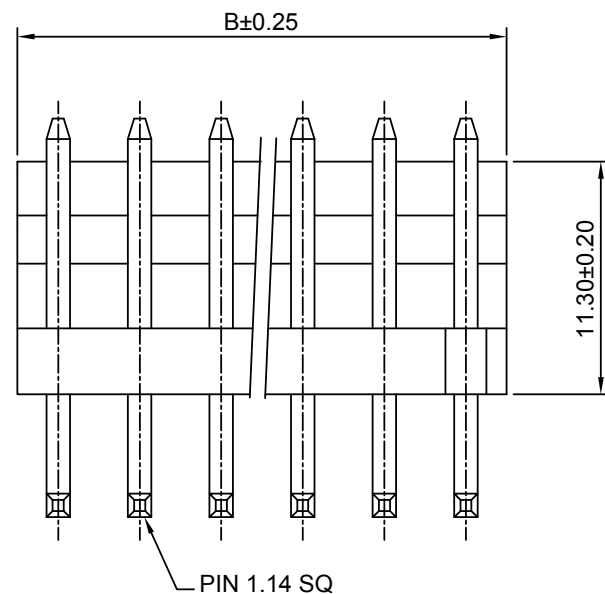

深圳市华德共创科技有限公司

SHENZHEN HUADE CO-CREATE TECHNOLOGY CO.,LTD

TEL : 0755-27129737 FAX : 0755-29940187

-TOLERANCES- UNLESS OTHERWISE SPECIFIED 公差参数表				TITLE: 3.96mm Pitch 产品名称: 180° Wafer	
X.X	±0.30	X.X°	±3°	APPD: 核准:	XIE
X.XX	±0.30	X.XX°	±2°	CHECK: 校对:	WANG
X.XXX	±0.10	X.XXX°	±1°	DRAW: 绘图:	WANG
PART NO: 产品编号:		HDGC3961WR-XP			
DATE	SCALE	UNIT	CODE NUMBER		
2013-12-06	3:1	mm	A008		

修订 REV	标记 MARK	修改摘要 REVISION DESCRIPTION	签名 SIGNATURE	日期 DATE
AO		NEW RELEASE	WANG	2013-12-06

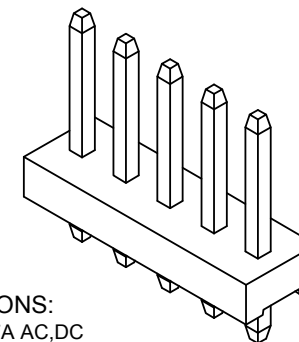
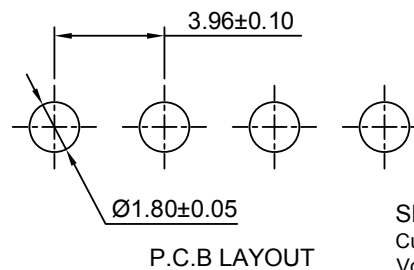
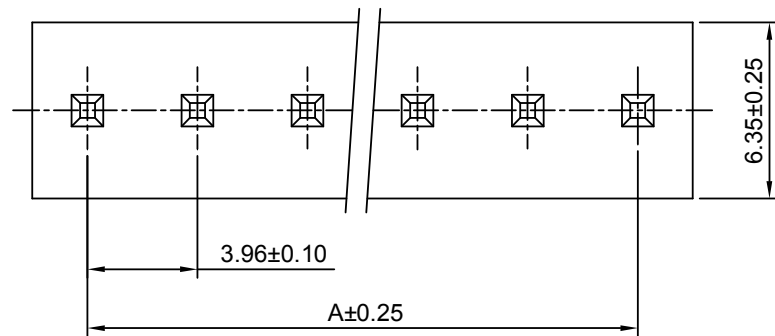

SPECIFICATIONS:

Current Rating: 7A AC,DC
Voltage Rating: 250V AC,DC
Temperature Range: $-25^{\circ}\text{C} \sim +85^{\circ}\text{C}$
Contact Resistance: 10m Ω Max
Insulation Resistance: 1000M Ω Min
Withstanding Voltage: 1500V AC/minute
Pin Material: Brass/Tin over Nickel
Material: Nylon 66,UL94V-2(Natural)

Ordering Information & Dimensions

Circuits	Dimensions(mm)		Circuits	Dimensions(mm)	
	A	B		A	B
2P	3.96	7.92	12P	43.56	47.52
3P	7.92	11.88	13P	47.52	51.48
4P	11.88	15.84	14P	51.48	55.44
5P	15.84	19.80	15P	55.44	59.40
6P	19.80	23.76	16P	59.40	63.36
7P	23.76	27.72	17P	63.36	67.32
8P	27.72	31.68	18P	67.32	71.28
9P	31.68	35.64	19P	71.28	75.24
10P	35.64	39.60	20P	75.24	79.20
11P	39.60	43.56			

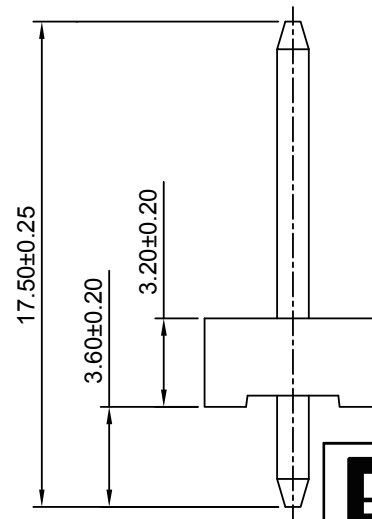
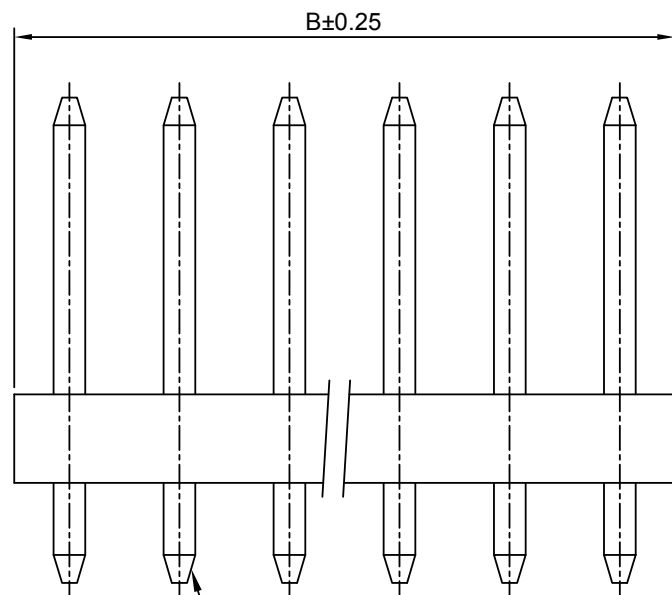

深圳市华德共创科技有限公司

SHENZHEN HUADE CO-CREATE TECHNOLOGY CO.,LTD

TEL : 0755-27129737 FAX : 0755-29940187

-TOLERANCES- UNLESS OTHERWISE SPECIFIED 公差参数表				TITLE: 3.96mm Pitch 产品名称: 180° Wafer	
X.X	± 0.30	X.X°	$\pm 3^{\circ}$	APPD: 核准:	XIE
X.XX	± 0.30	X.XX°	$\pm 2^{\circ}$	CHECK: 校对:	WANG
X.XXX	± 0.10	X.XXX°	$\pm 1^{\circ}$	DRAW: 绘图:	WANG
PART NO: 产品编号:		HDGC3961WVA-XP			
DATE	SCALE	UNIT	CODE NUMBER		
2013-12-06	4:1	mm	A008		

修订 REV	标记 MARK	修改摘要 REVISION DESCRIPTION	签名 SIGNATURE	日期 DATE
AO		NEW RELEASE	WANG	2013-12-06

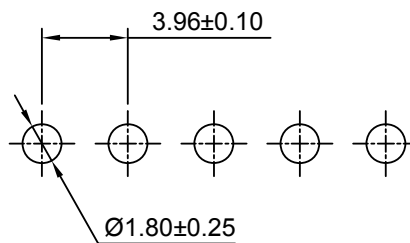
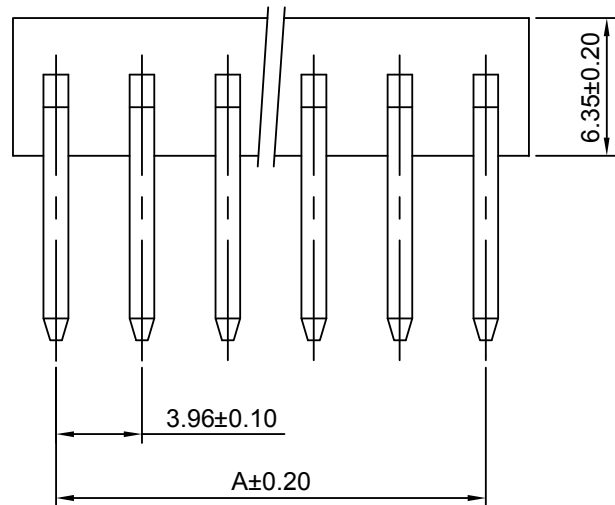

P.C.B LAYOUT

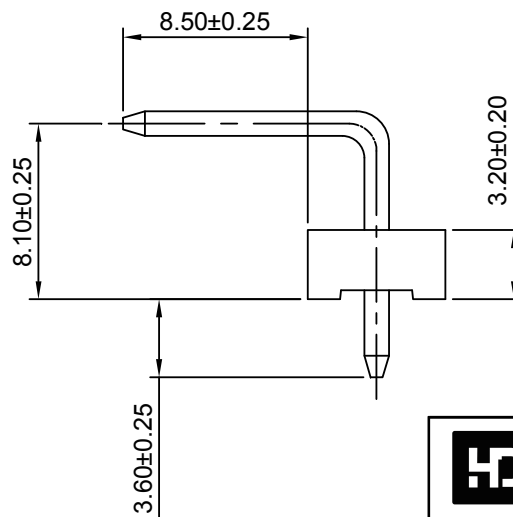
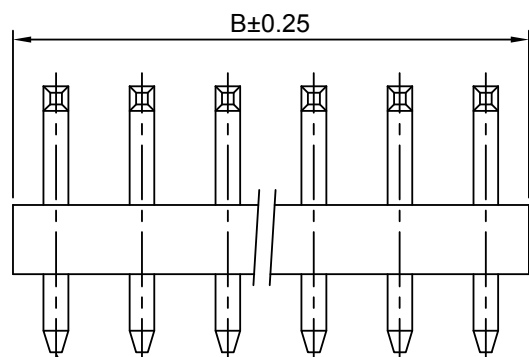

SPECIFICATIONS:

Current Rating: 7A AC,DC
Voltage Rating: 250V AC,DC
Temperature Range: -25°C ~ +85°C
Contact Resistance: 10mΩ Max
Insulation Resistance: 1000MΩ Min
Withstanding Voltage: 1500V AC/minute
Pin Material: Brass/Tin over Nickel(Tin:120u" Nickel:60u")
Material: Nylon 66,UL94V-2 (Natural)

Ordering Information & Dimensions

Circuits	Dimensions(mm)		Circuits	Dimensions(mm)	
	A	B		A	B
2P	3.96	7.92	14P	51.48	55.44
3P	7.92	11.88	15P	55.44	59.40
4P	11.88	15.84	16P	59.40	63.36
5P	15.84	19.80	17P	63.36	67.32
6P	19.80	23.76	18P	67.32	71.28
7P	23.76	27.72	19P	71.28	75.24
8P	27.72	31.68	20P	75.24	79.20
9P	31.68	35.64	21P	79.20	83.16
10P	35.64	39.60	22P	83.16	87.12
11P	39.60	43.56	23P	87.12	91.08
12P	43.56	47.52	24P	91.08	95.04
13P	47.52	51.48			



深圳市华德共创科技有限公司

SHENZHEN HUADE CO-CREATE TECHNOLOGY CO.,LTD

TEL : 0755-27129737 FAX : 0755-29940187

-TOLERANCES- UNLESS OTHERWISE SPECIFIED 公差参数表						TITLE: 3.96mm Pitch 产品名称: 180° Wafer			
X.X	±0.30	X.X°	±3°	APPD: 核准:	XIE	PART NO: 产品编号: HDGC3961WRA-XP			
X.XX	±0.30	X.XX°	±2°	CHECK: 校对:	WANG	DATE	SCALE	UNIT	CODE NUMBER
X.XXX	±0.10	X.XXX°	±1°	DRAW: 绘图:	WANG	2013-12-06	3:1	mm	A008

修订 REV	标记 MARK	修改摘要 REVISION DESCRIPTION	签名 SIGNATURE	日期 DATE
AO		NEW RELEASE	WANG	2013-12-06

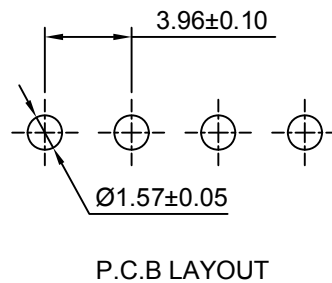
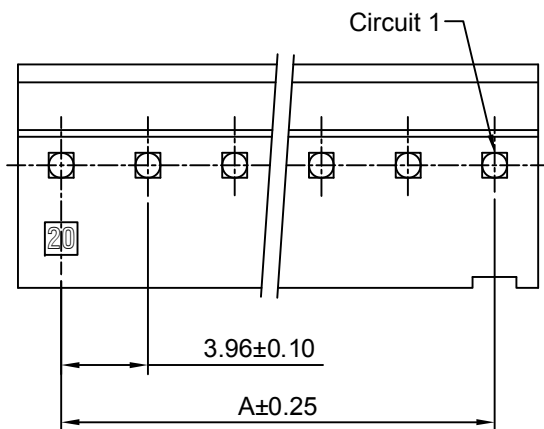

SPECIFICATIONS:

Current Rating: 7A AC,DC
Voltage Rating: 250V AC,DC
Temperature Range: -25°C ~ +85°C
Contact Resistance: 10mΩ Max
Insulation Resistance: 1000MΩ Min
Withstanding Voltage: 1500V AC/minute
Pin Material: Brass/Tin over Nickel
Material: Nylon 66,UL94V-2(Natural)

Ordering Information & Dimensions

Circuits	Dimensions(mm)		Circuits	Dimensions(mm)	
	A	B		A	B
2P	3.96	7.92	12P	43.56	47.52
3P	7.92	11.88	13P	47.52	51.48
4P	11.88	15.84	14P	51.48	55.44
5P	15.84	19.80	15P	55.44	59.40
6P	19.80	23.76	16P	59.40	63.36
7P	23.76	27.72	17P	63.36	67.32
8P	27.72	31.68	18P	67.32	71.28
9P	31.68	35.64	19P	71.28	75.24
10P	35.64	39.60	20P	75.24	79.20
11P	39.60	43.56			

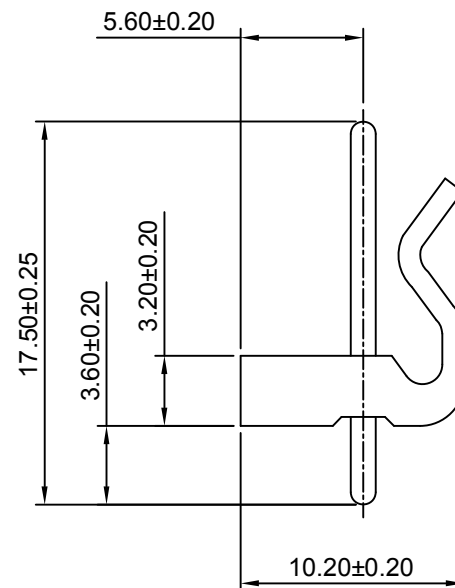
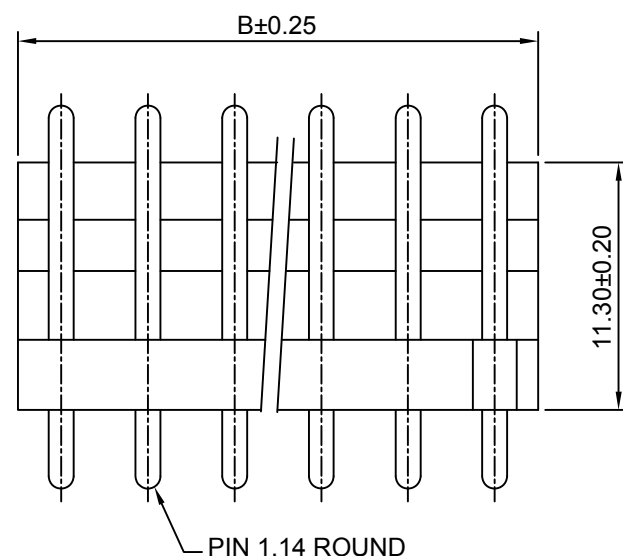

深圳市华德共创科技有限公司
SHENZHEN HUADE CO-CREATE TECHNOLOGY CO.,LTD
TEL : 0755-27129737 FAX : 0755-29940187

-TOLERANCES- UNLESS OTHERWISE SPECIFIED 公差参数表					TITLE: 3.96mm Pitch 产品名称: 180° Wafer			
X.X	±0.30	X.X°	±3°	APPD: 核准:	XIE			
X.XX	±0.30	X.XX°	±2°	CHECK: 校对:	WANG			
X.XXX	±0.10	X.XXX°	±1°	DRAW: 绘图:	WANG			
				PART NO: 产品编号:	HDGC3961WV-XP-R			
				DATE	SCALE	UNIT	CODE NUMBER	
				2013-12-06	3:1	mm	A008	

修订 REV	标记 MARK	修改摘要 REVISION DESCRIPTION	签名 SIGNATURE	日期 DATE
AO		NEW RELEASE	WANG	2013-12-06

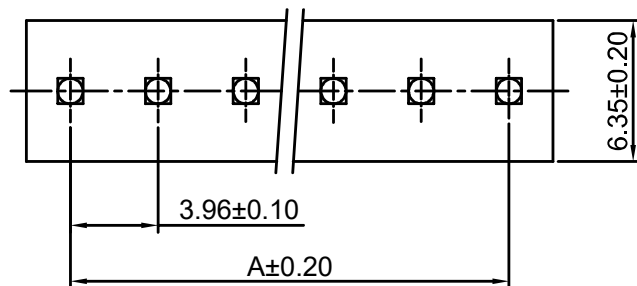
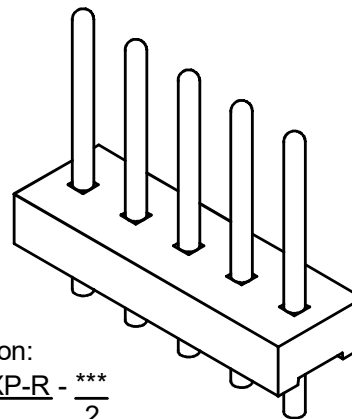
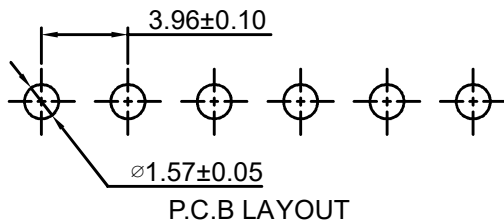

Ordering Information:
HDGC3961WVA-XP-R - $\frac{***}{2}$

- Part No.
- Material:
(blank): Nylon 66, UL94V-2
V0: Nylon 66, UL94V-0
GWT: Nylon 66, UL94V-0, GWT 750°C
- Finish:
(blank): Tin over Nickel
G: Gold over Nickel

SPECIFICATIONS:

Current Rating: 7A AC, DC
Voltage Rating: 250V AC, DC
Temperature Range: -25°C ~ +85°C
Contact Resistance: 10mΩ Max
Insulation Resistance: 1000MΩ Min
Withstanding Voltage: 1500V AC/minute
Pin Material: Brass/Tin over Nickel(Tin:120u" Nickel:60u")
Material: Nylon 66, UL94V-2 (Natural)

Ordering Information & Dimensions

Circuits	Dimensions(mm)		Circuits	Dimensions(mm)	
	A	B		A	B
2P	3.96	7.92	14P	51.48	55.44
3P	7.92	11.88	15P	55.44	59.40
4P	11.88	15.84	16P	59.40	63.36
5P	15.84	19.80	17P	63.36	67.32
6P	19.80	23.76	18P	67.32	71.28
7P	23.76	27.72	19P	71.28	75.24
8P	27.72	31.68	20P	75.24	79.20
9P	31.68	35.64	21P	79.20	83.16
10P	35.64	39.60	22P	83.16	87.12
11P	39.60	43.56	23P	87.12	91.08
12P	43.56	47.52	24P	91.08	95.04
13P	47.52	51.48			

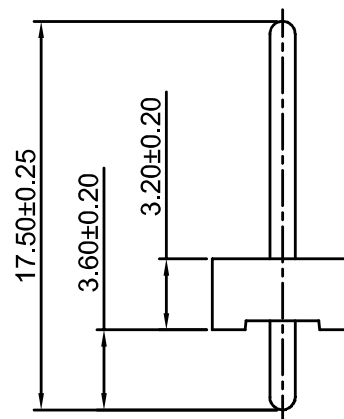
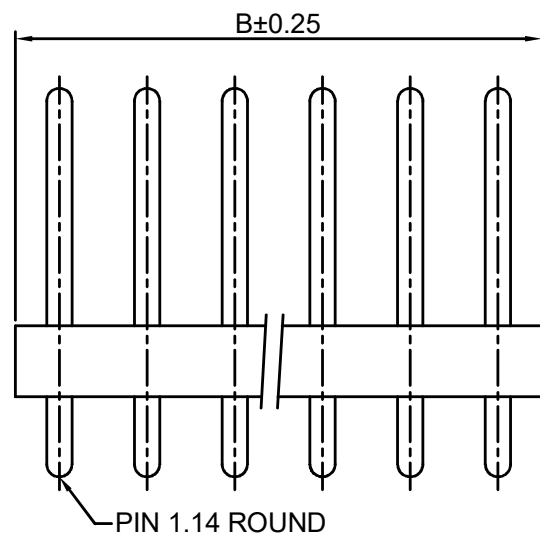

深圳市华德共创科技有限公司

SHENZHEN HUADE CO-CREATE TECHNOLOGY CO., LTD

TEL : 0755-27129737 FAX : 0755-29940187

-TOLERANCES- UNLESS OTHERWISE SPECIFIED 公差参数表				TITLE: 3.96mm Pitch 产品名称: 180° Wafer	
X.X	±0.30	X.X°	±3°	APPD: 核准:	XIE
X.XX	±0.30	X.XX°	±2°	CHECK: 校对:	WANG
X.XXX	±0.10	X.XXX°	±1°	DRAW: 绘图:	WANG
PART NO: 产品编号:		HDGC3961WVA-XP-R			
DATE	SCALE	UNIT	CODE NUMBER		
2013-12-06	3:1	mm	A008		

修订 REV	标记 MARK	修改摘要 REVISION DESCRIPTION	签名 SIGNATURE	日期 DATE
AO		NEW RELEASE	WANG	2013-12-06

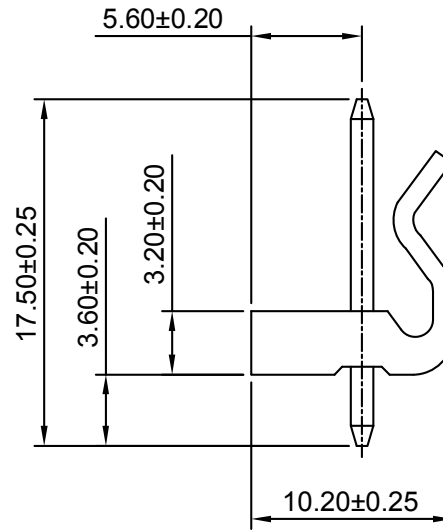
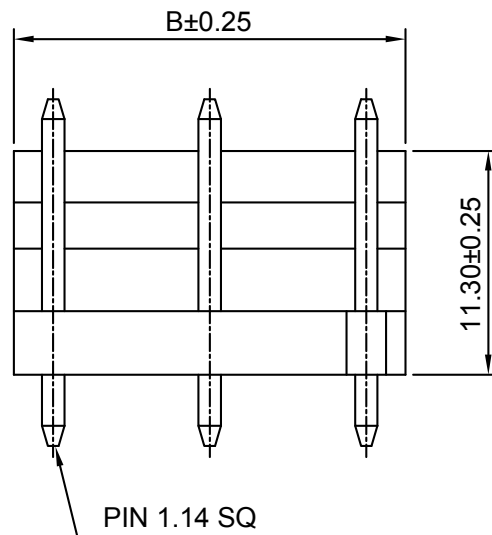
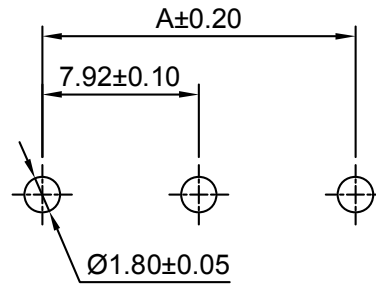
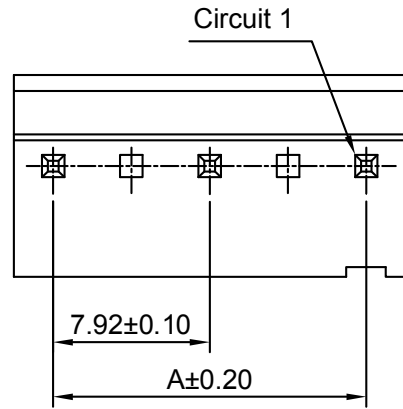

SPECIFICATIONS:

Current Rating: 7A AC,DC
Voltage Rating: 250V AC,DC
Temperature Range: -25°C ~ +85°C
Contact Resistance: 10mΩ Max
Insulation Resistance: 1000MΩ Min
Withstanding Voltage: 1500V AC/minute
Pin Material: Brass/Tin over Nickel
Material: Nylon 66,UL94V-2(Natural)

Ordering Information & Dimensions

Circuits	Dimensions(mm)		Circuits	Dimensions(mm)	
	A	B		A	B
3P	7.92	11.88	13P	47.52	51.48
5P	15.84	19.80	15P	55.44	59.40
7P	23.76	27.72	17P	63.36	67.32
9P	31.68	35.64	19P	71.28	75.24
11P	39.60	43.56			



深圳市华德共创科技有限公司

SHENZHEN HUADE CO-CREATE TECHNOLOGY CO.,LTD

TEL : 0755-27129737 FAX : 0755-29940187

-TOLERANCES- UNLESS OTHERWISE SPECIFIED 公差参数表				TITLE: 7.92mm Pitch 产品名称: 180° Wafer	
X.X	±0.30	X.X°	±3°	APPD: 核准:	XIE
X.XX	±0.30	X.XX°	±2°	CHECK: 校对:	WANG
X.XXX	±0.10	X.XXX°	±1°	DRAW: 绘图:	WANG
PART NO: 产品编号:		HDGC3961WV-XP-A			
DATE	SCALE	UNIT	CODE NUMBER		
2013-12-06	2.5:1	mm	A008		

修订 REV	标记 MARK	修改摘要 REVISION DESCRIPTION	签名 SIGNATURE	日期 DATE
AO		NEW RELEASE	WANG	2013-12-06

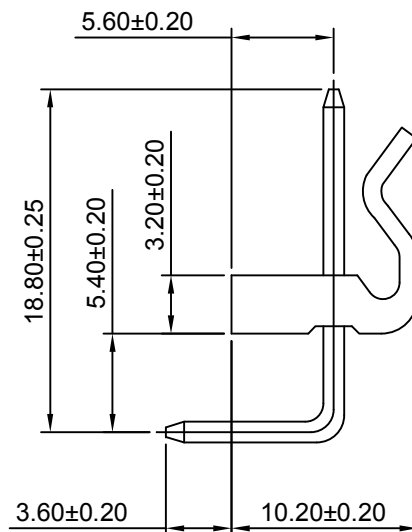
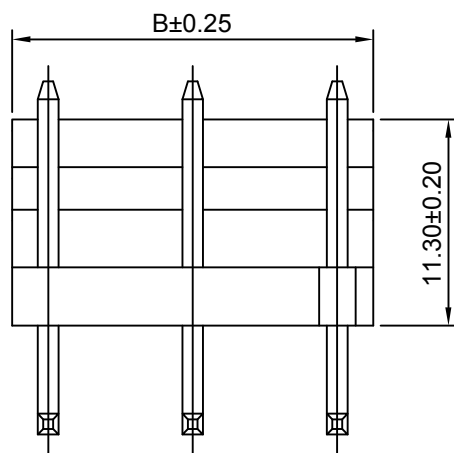
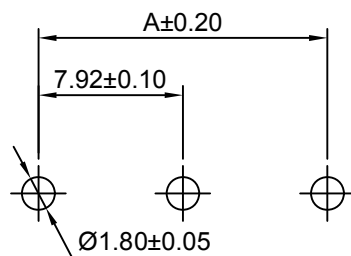
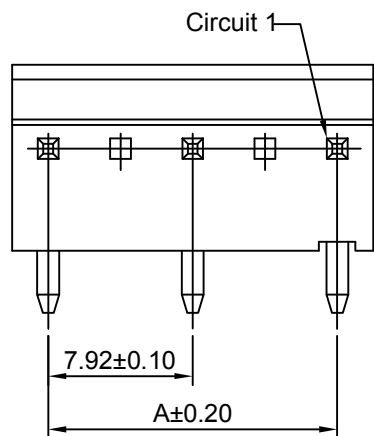

SPECIFICATIONS:

Current Rating: 7A AC,DC
Voltage Rating: 250V AC,DC
Temperature Range: -25°C ~ +85°C
Contact Resistance: 10mΩ Max
Insulation Resistance: 1000MΩ Min
Withstanding Voltage: 1500V AC/minute
Pin Material: Brass/Tin over Nickel
Material: Nylon 66,UL94V-2(Natural)

Ordering Information & Dimensions

Circuits	Dimensions(mm)		Circuits	Dimensions(mm)	
	A	B		A	B
3P	7.92	11.88	13P	47.52	51.48
5P	15.84	19.80	15P	55.44	59.40
7P	23.76	27.72	17P	63.36	67.32
9P	31.68	35.64	19P	71.28	75.24
11P	39.60	43.56			



深圳市华德共创科技有限公司

SHENZHEN HUADE CO-CREATE TECHNOLOGY CO.,LTD

TEL : 0755-27129737 FAX : 0755-29940187

-TOLERANCES- UNLESS OTHERWISE SPECIFIED 公差参数表						TITLE: 7.92mm Pitch 产品名称: 90° Wafer			
X.X	±0.30	X.X°	±3°	APPD: 核准:	XIE	PART NO: 产品编号: HDGC3961WR-XP-A			
X.XX	±0.30	X.XX°	±2°	CHECK: 校对:	WANG	DATE	SCALE	UNIT	CODE NUMBER
X.XXX	±0.10	X.XXX°	±1°	DRAW: 绘图:	WANG	2013-12-06	2.5:1	mm	A008

修订 REV	标记 MARK	修改摘要 REVISION DESCRIPTION	签名 SIGNATURE	日期 DATE
AO		NEW RELEASE	WANG	2013-12-06

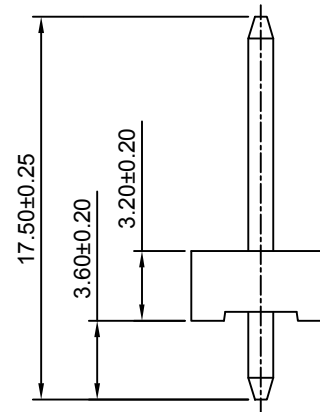
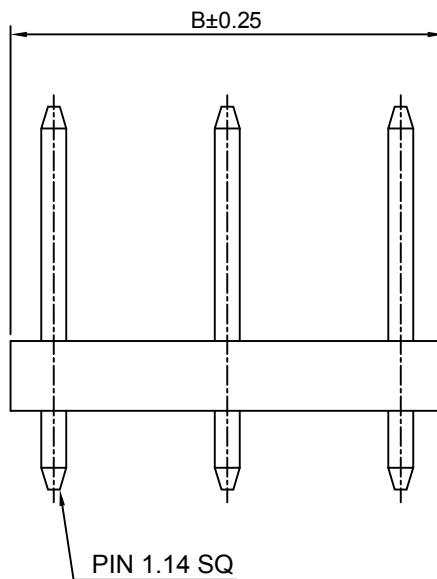
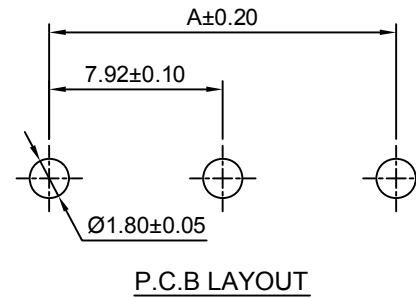
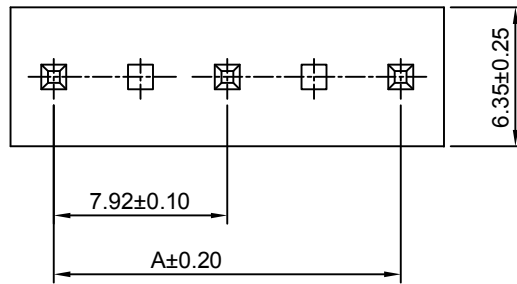

SPECIFICATIONS:

Current Rating: 7A AC,DC
Voltage Rating: 250V AC,DC
Temperature Range: $-25^{\circ}\text{C} \sim +85^{\circ}\text{C}$
Contact Resistance: 10m Ω Max
Insulation Resistance: 1000M Ω Min
Withstanding Voltage: 1500V AC/minute
Pin Material: Brass/Tin over Nickel
Material: Nylon 66,UL94V-2(Natural)

Ordering Information & Dimensions

Circuits	Dimensions(mm)		Circuits	Dimensions(mm)	
	A	B		A	B
3P	7.92	11.88	13P	47.52	51.48
5P	15.84	19.80	15P	55.44	59.40
7P	23.76	27.72	17P	63.36	67.32
9P	31.68	35.64	19P	71.28	75.24
11P	39.60	43.56			



深圳市华德共创科技有限公司

SHENZHEN HUADE CO-CREATE TECHNOLOGY CO.,LTD

TEL : 0755-27129737 FAX : 0755-29940187

-TOLERANCES- UNLESS OTHERWISE SPECIFIED 公差参数表				TITLE: 7.92mm Pitch 产品名称: 180° Wafer	
X.X	± 0.30	X.X°	$\pm 3^{\circ}$	APPD: 核准:	XIE
X.XX	± 0.30	X.XX°	$\pm 2^{\circ}$	CHECK: 校对:	WANG
X.XXX	± 0.10	X.XXX°	$\pm 1^{\circ}$	DRAW: 绘图:	WANG
				PART NO: 产品编号:	HDGC3961WVA-XP-A
		DATE	SCALE	UNIT	CODE NUMBER
		2013-12-06	3:1	mm	A008

修订 REV	标记 MARK	修改摘要 REVISION DESCRIPTION	签名 SIGNATURE	日期 DATE
AO		NEW RELEASE	WANG	2013-12-06

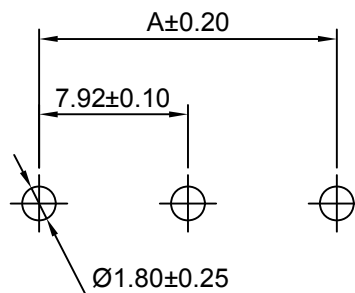
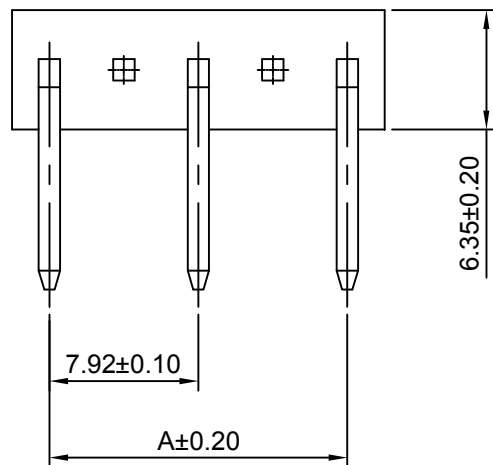

P.C.B LAYOUT

SPECIFICATIONS:

Current Rating: 7A AC,DC
Voltage Rating: 250V AC,DC
Temperature Range: $-25^{\circ}\text{C} \sim +85^{\circ}\text{C}$
Contact Resistance: 10m Ω Max
Insulation Resistance: 1000M Ω Min
Withstanding Voltage: 1500V AC/minute
Pin Material: Brass/Tin over Nickel(Tin:120u" Nickel:60u")
Material: Nylon 66,UL94V-2 (Natural)

Ordering Information & Dimensions

Circuits	Dimensions(mm)		Circuits	Dimensions(mm)	
	A	B		A	B
3P	7.92	11.88	13P	47.52	51.48
5P	15.84	19.80	15P	55.44	59.40
7P	23.76	27.72	17P	63.36	67.32
9P	31.68	35.64	19P	71.28	75.24
11P	39.60	43.56			

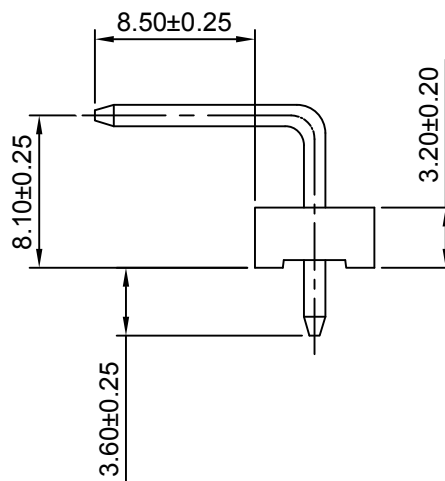
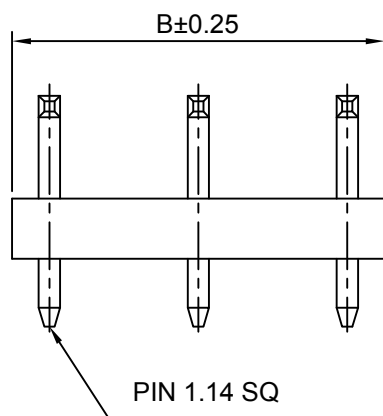

深圳市华德共创科技有限公司
SHENZHEN HUADE CO-CREATE TECHNOLOGY CO.,LTD
TEL : 0755-27129737 FAX : 0755-29940187

-TOLERANCES- UNLESS OTHERWISE SPECIFIED 公差参数表					TITLE: 7.92mm Pitch 产品名称: 90° Wafer							
X.X	±0.30	X.X°	±3°	APPD: 核准:	XIE				PART NO: 产品编号:	HDGC3961WRA-XP-A		
X.XX	±0.30	X.XX°	±2°	CHECK: 校对:	WANG		DATE	SCALE	UNIT	CODE NUMBER		
X.XXX	±0.10	X.XXX°	±1°	DRAW: 绘图:	WANG		2013-12-06	2.5:1	mm	A008		

修订 REV	标记 MARK	修改摘要 REVISION DESCRIPTION	签名 SIGNATURE	日期 DATE
AO		NEW RELEASE	WANG	2013-12-06

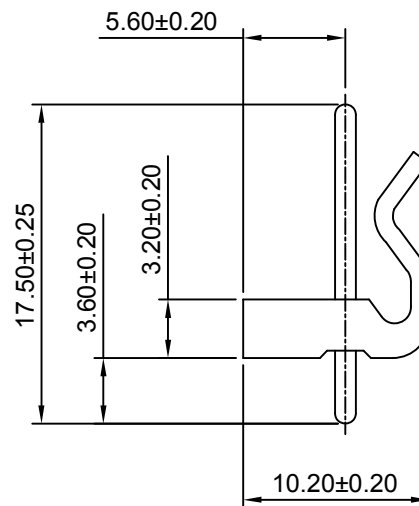
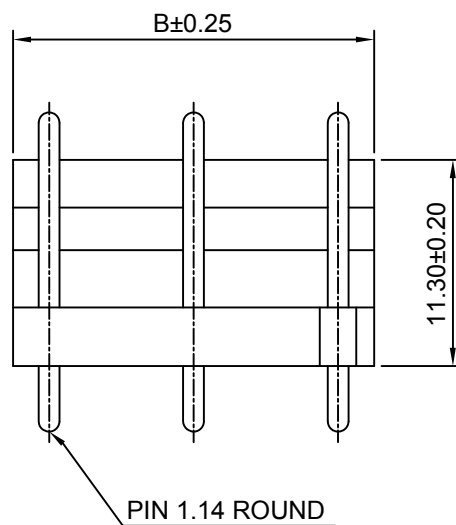
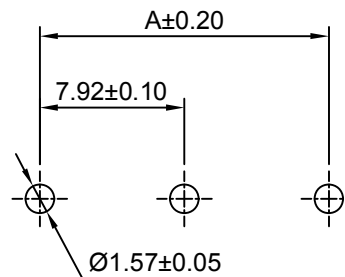
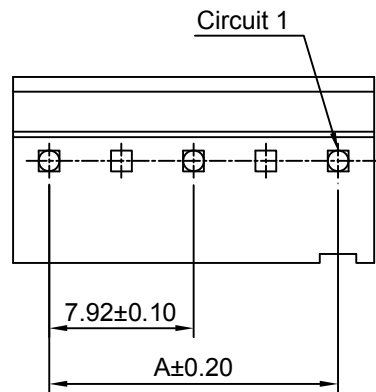

SPECIFICATIONS:

Current Rating: 7A AC,DC
Voltage Rating: 250V AC,DC
Temperature Range: -25°C ~ +85°C
Contact Resistance: 10mΩ Max
Insulation Resistance: 1000MΩ Min
Withstanding Voltage: 1500V AC/minute
Pin Material: Brass/Tin over Nickle
Material: Nylon 66,UL94V-2(Natural)

Ordering Information & Dimensions

Circuits	Dimensions(mm)		Circuits	Dimensions(mm)	
	A	B		A	B
3P	7.92	11.88	13P	47.52	51.48
5P	15.84	19.80	15P	55.44	59.40
7P	23.76	27.72	17P	63.36	67.32
9P	31.68	35.64	19P	71.28	75.24
11P	39.60	43.56			



深圳市华德共创科技有限公司

SHENZHEN HUADE CO-CREATE TECHNOLOGY CO.,LTD

TEL : 0755-27129737 FAX : 0755-29940187

-TOLERANCES- UNLESS OTHERWISE SPECIFIED 公差参数表			 		TITLE: 7.92mm Pitch 产品名称: 180° Wafer			
X.X	±0.30	X.X° ±3°	APPD: 核准:	XIE	PART NO: 产品编号: HDGC3961WV-XP-R-A			
X.XX	±0.30	X.XX° ±2°	CHECK: 校对:	WANG	DATE	SCALE	UNIT	CODE NUMBER
X.XXX	±0.10	X.XXX° ±1°	DRAW: 绘图:	WANG	2013-12-06	2.5:1	mm	A008

修订 REV	标记 MARK	修改摘要 REVISION DESCRIPTION	签名 SIGNATURE	日期 DATE
AO		NEW RELEASE	WANG	2013-12-06

Ordering Information:
HDGC3961WVA-XP-R-A - $\frac{***}{2} - \frac{**}{3}$

- Part No.
- Material:
 (blank): Nylon 66, UL94V-2
 V0: Nylon 66, UL94V-0
 GWT: Nylon 66, UL94V-0, GWT 750°C
- Finish:
 (blank): Tin over Nickel
 G: Gold over Nickel

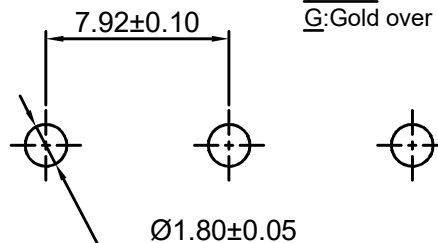
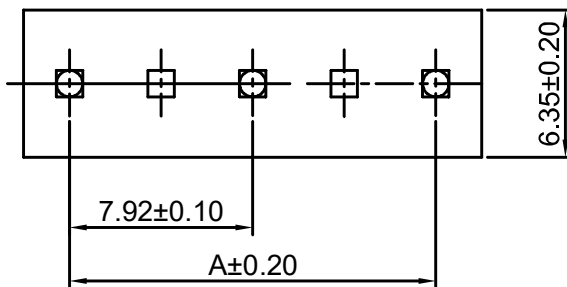
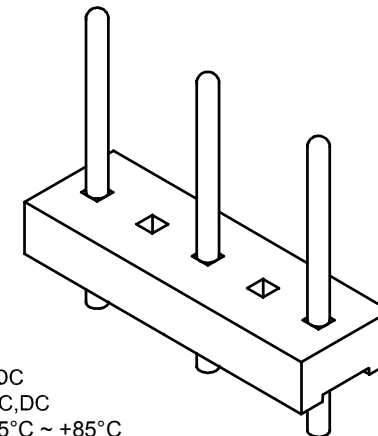

P.C.B LAYOUT

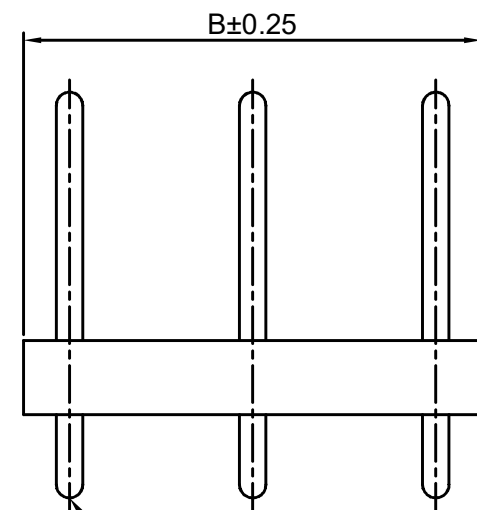

SPECIFICATIONS:

Current Rating: 7A AC,DC
 Voltage Rating: 250V AC,DC
 Temperature Range: -25°C ~ +85°C
 Contact Resistance: 10mΩ Max
 Insulation Resistance: 1000MΩ Min
 Withstanding Voltage: 1500V AC/minute
 Pin Material: Brass/Tin over Nickel
 Material: Nylon 66, UL94V-0(White)

Ordering Information & Dimensions:

PART NO.	Dimensions	
	A	B
3P	7.92	11.88
5P	15.84	19.80
7P	23.76	27.72
9P	31.68	35.64
11P	39.60	43.56
13P	47.52	51.48
15P	55.44	59.40
17P	63.36	67.32
19P	71.28	75.24

Unit: mm



深圳市华德共创科技有限公司

SHENZHEN HUADE CO-CREATE TECHNOLOGY CO., LTD

TEL : 0755-27129737 FAX : 0755-29940187

-TOLERANCES- UNLESS OTHERWISE SPECIFIED 公差参数表				TITLE: 7.92mm Pitch 产品名称: 180° Wafer	
X.X	±0.30	X.X°	±3°	APPD: 核准:	XIE
X.XX	±0.30	X.XX°	±2°	CHECK: 校对:	WANG
X.XXX	±0.10	X.XXX°	±1°	DRAW: 绘图:	WANG
PART NO: 产品编号:		HDGC3961WVA-XP-R-A			
DATE	SCALE	UNIT	CODE NUMBER		
2013-12-06	2.5:1	mm	A008		

修订 REV	标记 MARK	修改摘要 REVISION DESCRIPTION	签名 SIGNATURE	日期 DATE
AO		NEW RELEASE	WANG	2013-12-06

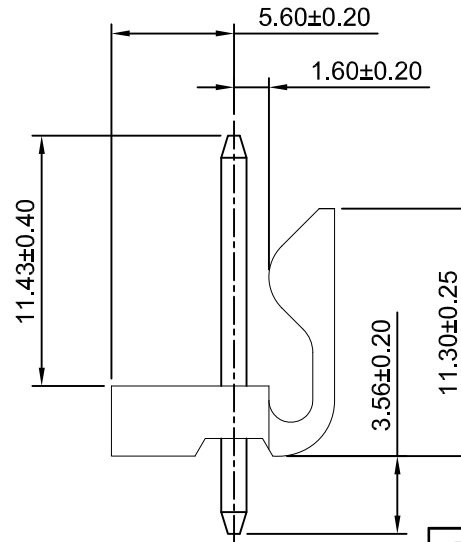
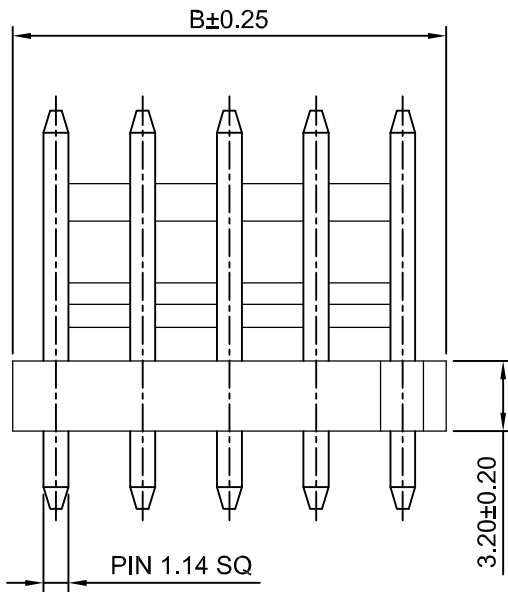
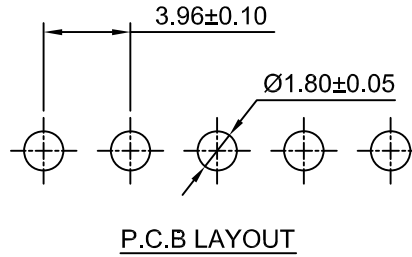
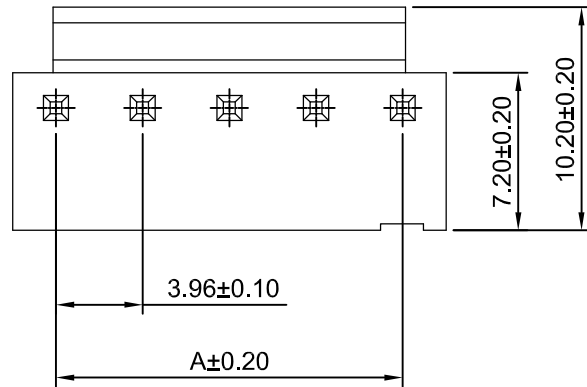

SPECIFICATIONS:

Current Rating: 7A AC,DC
Voltage Rating: 250V AC,DC
Temperature Range: -25°C ~ +85°C
Contact Resistance: 10mΩ Max
Insulation Resistance: 1000MΩ Min
Withstanding Voltage: 1500V AC/minute
Pin Material: Brass/Tin over Nickel
Material: Nylon 66,UL94V-0(White)

Ordering Information & Dimensions

Circuits	Dimensions(mm)		Circuits	Dimensions(mm)	
	A	B		A	B
2P	3.96	7.92	12P	43.56	47.52
3P	7.92	11.88	13P	47.52	51.48
4P	11.88	15.84	14P	51.48	55.44
5P	15.84	19.80	15P	55.44	59.40
6P	19.80	23.76	16P	59.40	63.36
7P	23.76	27.72	17P	63.36	67.32
8P	27.72	31.68	18P	67.32	71.28
9P	31.68	35.64	19P	71.28	75.24
10P	35.64	39.60	20P	75.24	79.20
11P	39.60	43.56			



深圳市华德共创科技有限公司

SHENZHEN HUADE CO-CREATE TECHNOLOGY CO.,LTD

TEL : 0755-27129737 FAX : 0755-29940187

-TOLERANCES- UNLESS OTHERWISE SPECIFIED 公差参数表				TITLE: 3.96mm Pitch 产品名称: 180° Wafer	
X.X	±0.30	X.X°	±3°	APPD: 核准:	XIE
X.XX	±0.30	X.XX°	±2°	CHECK: 校对:	WANG
X.XXX	±0.10	X.XXX°	±1°	DRAW: 绘图:	WANG
PART NO: 产品编号:		HDGC3961WVB-XP			
DATE	SCALE	UNIT	CODE NUMBER		
2013-12-06	3:1	mm	A008		

修订 REV	标记 MARK	修改摘要 REVISION DESCRIPTION	签名 SIGNATURE	日期 DATE
AO		NEW RELEASE	WANG	2013-12-06

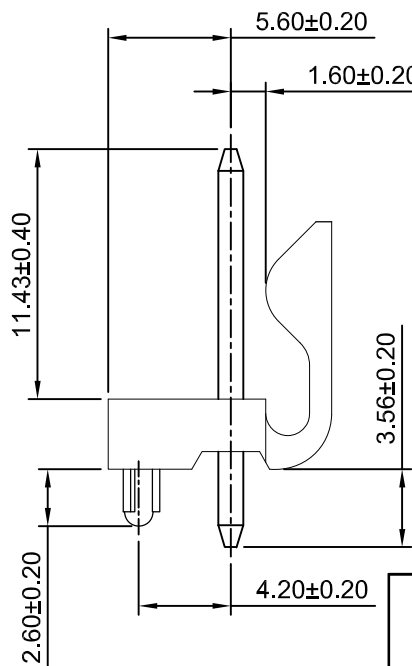
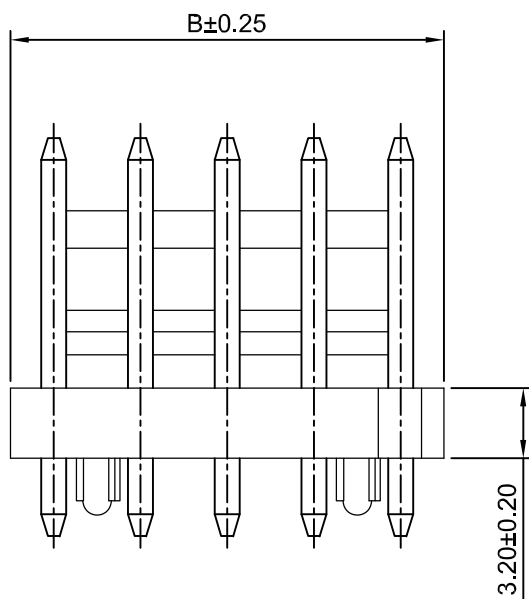
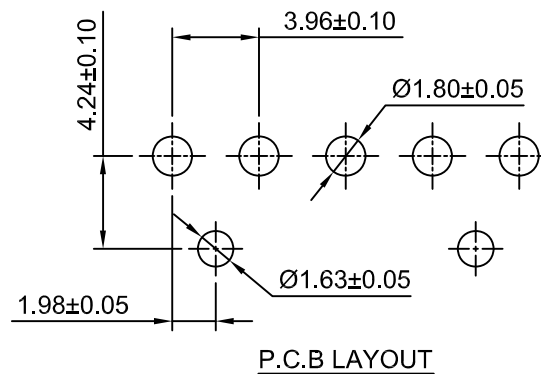
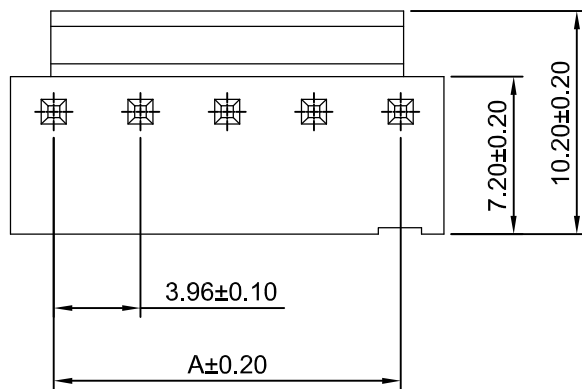

SPECIFICATIONS:

Current Rating: 7A AC,DC
Voltage Rating: 250V AC,DC
Temperature Range: -25°C ~ +85°C
Contact Resistance: 10mΩ Max
Insulation Resistance: 1000MΩ Min
Withstanding Voltage: 1500V AC/minute
Pin Material: Brass/Tin over Nickel(Tin:120u" Nickel:60u")
Material: Nylon 66,UL94V-0(White)

Ordering Information & Dimensions

Circuits	Dimensions(mm)		Circuits	Dimensions(mm)	
	A	B		A	B
2P	3.96	7.92	12P	43.56	47.52
3P	7.92	11.88	13P	47.52	51.48
4P	11.88	15.84	14P	51.48	55.44
5P	15.84	19.80	15P	55.44	59.40
6P	19.80	23.76	16P	59.40	63.36
7P	23.76	27.72	17P	63.36	67.32
8P	27.72	31.68	18P	67.32	71.28
9P	31.68	35.64	19P	71.28	75.24
10P	35.64	39.60	20P	75.24	79.20
11P	39.60	43.56			



深圳市华德共创科技有限公司

SHENZHEN HUADE CO-CREATE TECHNOLOGY CO.,LTD

TEL : 0755-27129737 FAX : 0755-29940187

-TOLERANCES- UNLESS OTHERWISE SPECIFIED 公差参数表						TITLE: 3.96mm Pitch 产品名称: 180° Wafer			
X.X	±0.30	X.X°	±3°	APPD: 核准:	XIE	PART NO: 产品编号: HDGC3961WVB-F-XP			
X.XX	±0.30	X.XX°	±2°	CHECK: 校对:	WANG	DATE	SCALE	UNIT	CODE NUMBER
X.XXX	±0.10	X.XXX°	±1°	DRAW: 绘图:	WANG	2013-12-06	3:1	mm	A008

修订 REV	标记 MARK	修改摘要 REVISION DESCRIPTION	签名 SIGNATURE	日期 DATE
AO		NEW RELEASE	WANG	2014-07-12

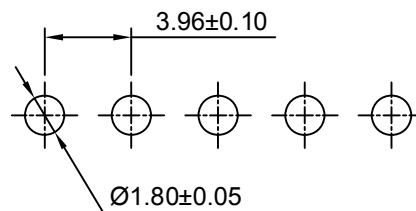
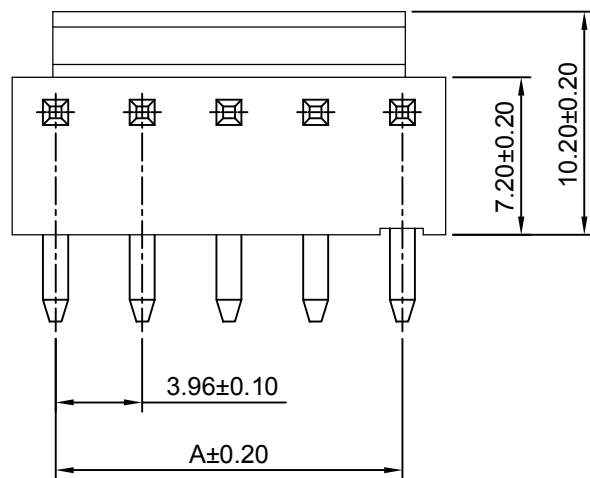

P.C.B LAYOUT

SPECIFICATIONS:

Current Rating: 7A AC,DC
Voltage Rating: 250V AC,DC
Temperature Range: -25°C ~ +85°C
Contact Resistance: 10mΩ Max
Insulation Resistance: 1000MΩ Min
Withstanding Voltage: 1500V AC/minute
Pin Material: Brass/Tin over Nickel(Tin:120u" Nickel:60u")
Material: Nylon 66,UL94V-0 (White)

Ordering Information & Dimensions

Circuits	Dimensions(mm)		Circuits	Dimensions(mm)	
	A	B		A	B
2P	3.96	7.92	14P	51.48	55.44
3P	7.92	11.88	15P	55.44	59.40
4P	11.88	15.84	16P	59.40	63.36
5P	15.84	19.80	17P	63.36	67.32
6P	19.80	23.76	18P	67.32	71.28
7P	23.76	27.72	19P	71.28	75.24
8P	27.72	31.68	20P	75.24	79.20
9P	31.68	35.64	21P	79.20	83.16
10P	35.64	39.60	22P	83.16	87.12
11P	39.60	43.56	23P	87.12	91.08
12P	43.56	47.52	24P	91.08	95.04
13P	47.52	51.48			

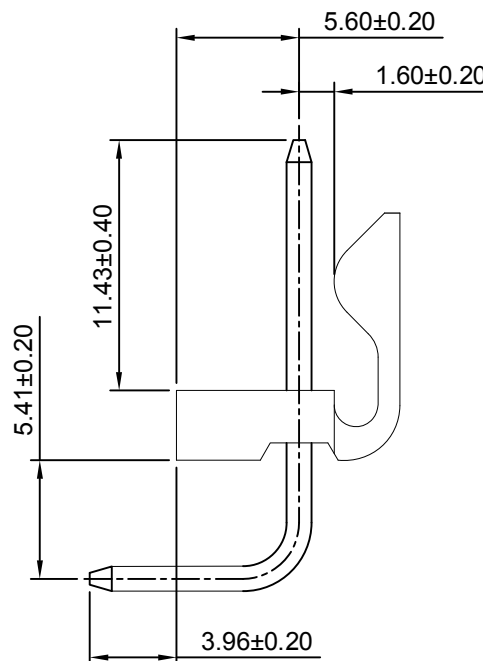
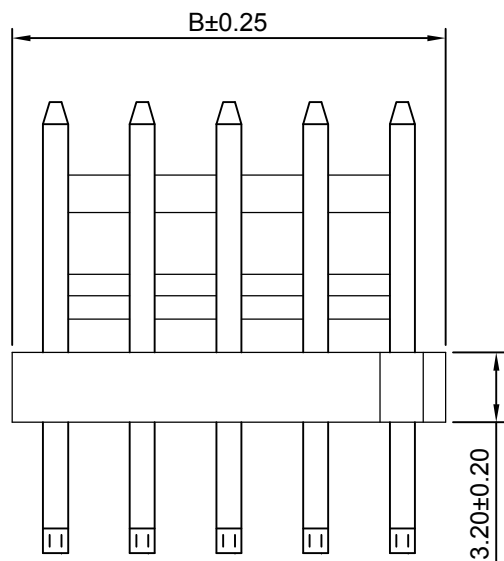

HDGC 深圳市华德共创科技有限公司
SHENZHEN HUADE CO-CREATE TECHNOLOGY CO.,LTD
TEL : 0755-27129737 FAX : 0755-29940187

-TOLERANCES- UNLESS OTHERWISE SPECIFIED 公差参数表						TITLE: 3.96mm Pitch 产品名称: 90° Wafer			
X.X	±0.30	X.X°	±3°	APPD: 核准:	XIE	PART NO: 产品编号: HDGC3961WRB-XP			
X.XX	±0.30	X.XX°	±2°	CHECK: 校对:	WANG	DATE	SCALE	UNIT	CODE NUMBER
X.XXX	±0.10	X.XXX°	±1°	DRAW: 绘图:	WANG	2014-07-12	3:1	mm	A008

修订 REV	标记 MARK	修改摘要 REVISION DESCRIPTION	签名 SIGNATURE	日期 DATE
AO		NEW RELEASE	WANG	2016-12-25

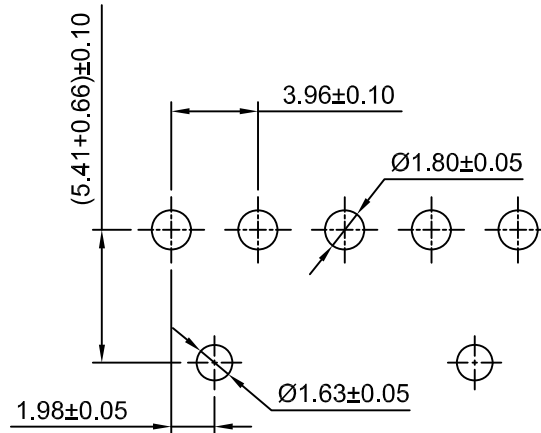
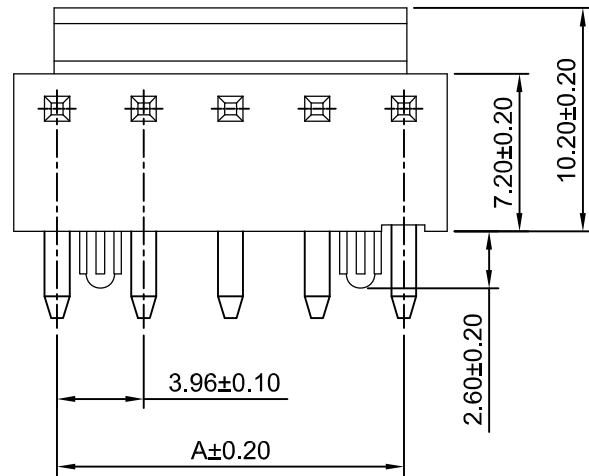

P.C.B LAYOUT

SPECIFICATIONS:

Current Rating: 7A AC,DC
Voltage Rating: 250V AC,DC
Temperature Range: -25°C ~ +85°C
Contact Resistance: 10mΩ Max
Insulation Resistance: 1000MΩ Min
Withstanding Voltage: 1500V AC/minute
Pin Material: Brass/Tin over Nickel(Tin:120u" Nickel:60u")
Material: Nylon 66,UL94V-0 (White)

Ordering Information & Dimensions

Circuits	Dimensions(mm)		Circuits	Dimensions(mm)	
	A	B		A	B
2P	3.96	7.92	14P	51.48	55.44
3P	7.92	11.88	15P	55.44	59.40
4P	11.88	15.84	16P	59.40	63.36
5P	15.84	19.80	17P	63.36	67.32
6P	19.80	23.76	18P	67.32	71.28
7P	23.76	27.72	19P	71.28	75.24
8P	27.72	31.68	20P	75.24	79.20
9P	31.68	35.64	21P	79.20	83.16
10P	35.64	39.60	22P	83.16	87.12
11P	39.60	43.56	23P	87.12	91.08
12P	43.56	47.52	24P	91.08	95.04
13P	47.52	51.48			

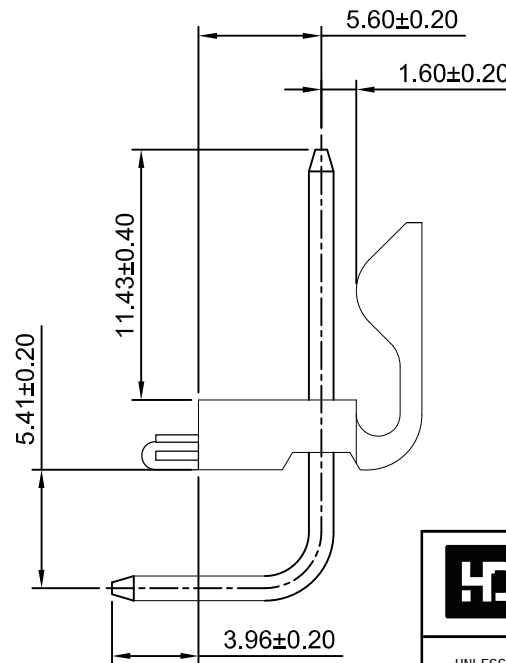
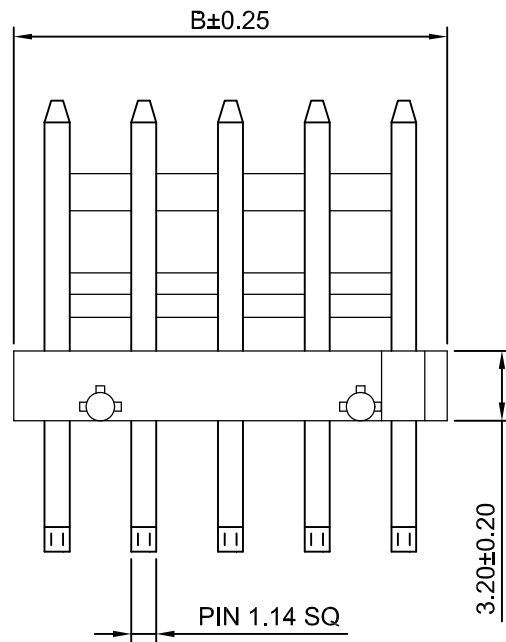

深圳市华德共创科技有限公司

SHENZHEN HUADE CO-CREATE TECHNOLOGY CO.,LTD

TEL : 0755-27129737 FAX : 0755-29940187

-TOLERANCES- UNLESS OTHERWISE SPECIFIED 公差参数表				TITLE: 产品名称: 3.96mm Pitch 90° Wafer	
X.X	±0.30	X.X°	±3°	APPD: 核准:	XIE
X.XX	±0.30	X.XX°	±2°	CHECK: 校对:	WANG
X.XXX	±0.10	X.XXX°	±1°	DRAW: 绘图:	WANG
				PART NO: 产品编号:	HDGC3961WRB-F-XP
		DATE	SCALE	UNIT	CODE NUMBER
		2016-12-25	3:1	mm	A008

修订 REV	标记 MARK	修改摘要 REVISION DESCRIPTION	签名 SIGNATURE	日期 DATE
AO		NEW RELEASE	WANG	2016-12-25

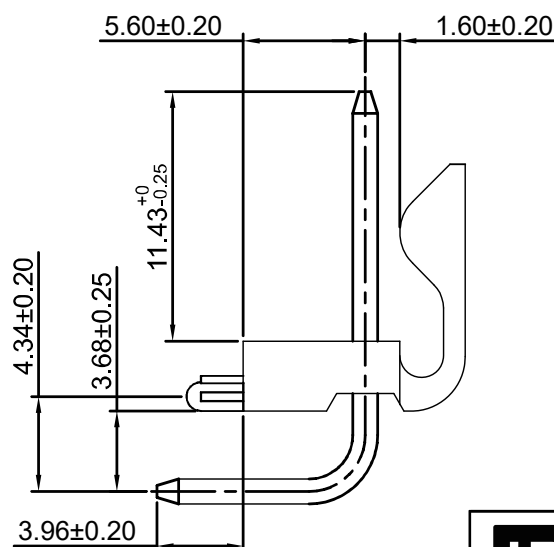
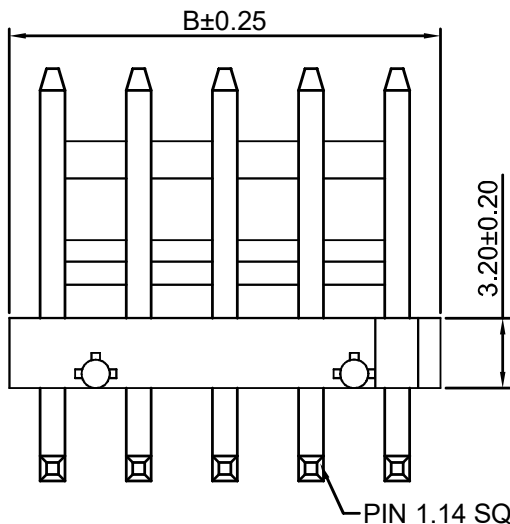
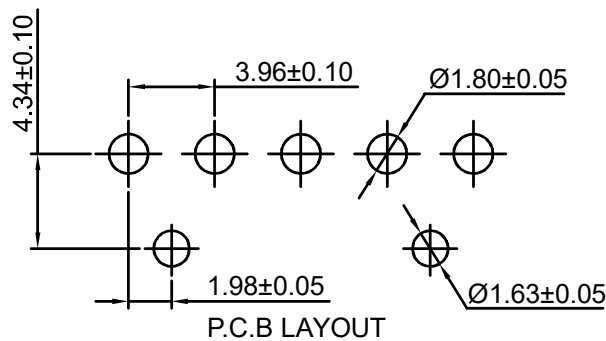
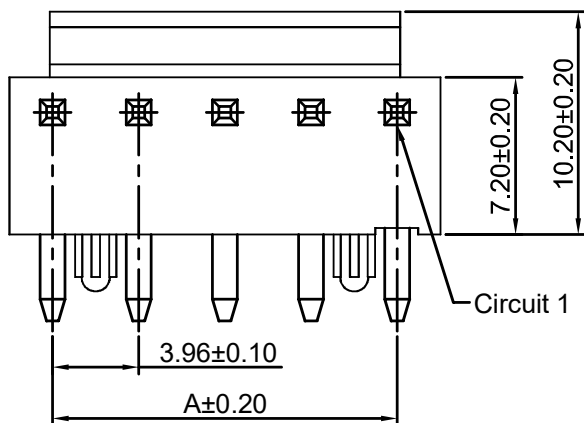

SPECIFICATIONS:

Current Rating: 7A AC,DC
Voltage Rating: 250V AC,DC
Temperature Range: -25°C ~ +85°C
Contact Resistance: 10mΩ Max
Insulation Resistance: 1000MΩ Min
Withstanding Voltage: 1500V AC/minute
Pin Material: Brass/Tin over Nickel(Tin:120u" Nickel:60u")
Material: Nylon 66,UL94V-0 (White)

Ordering Information & Dimensions

Circuits	Dimensions(mm)		Circuits	Dimensions(mm)	
	A	B		A	B
2P	3.96	7.92	14P	51.48	55.44
3P	7.92	11.88	15P	55.44	59.40
4P	11.88	15.84	16P	59.40	63.36
5P	15.84	19.80	17P	63.36	67.32
6P	19.80	23.76	18P	67.32	71.28
7P	23.76	27.72	19P	71.28	75.24
8P	27.72	31.68	20P	75.24	79.20
9P	31.68	35.64	21P	79.20	83.16
10P	35.64	39.60	22P	83.16	87.12
11P	39.60	43.56	23P	87.12	91.08
12P	43.56	47.52	24P	91.08	95.04
13P	47.52	51.48			



深圳市华德共创科技有限公司

SHENZHEN HUADE CO-CREATE TECHNOLOGY CO.,LTD

TEL : 0755-27129737 FAX : 0755-29940187

-TOLERANCES- UNLESS OTHERWISE SPECIFIED 公差参数表						TITLE: 3.96mm Pitch 产品名称: 90° Wafer			
X.X	±0.30	X.X°	±3°	APPD: 核准:	XIE	PART NO: 产品编号: HDGC3961WRB-F-L-XP			
X.XX	±0.30	X.XX°	±2°	CHECK: 校对:	WANG	DATE	SCALE	UNIT	CODE NUMBER
X.XXX	±0.10	X.XXX°	±1°	DRAW: 绘图:	WANG	2016-12-25	3:1	mm	A008

修订 REV	标记 MARK	修改摘要 REVISION DESCRIPTION	签名 SIGNATURE	日期 DATE
AO		NEW RELEASE	WANG	2013-12-06

Ordering Information:
 HDGC3961WVC-XP - $\frac{****}{2}$ - $\frac{***}{3}$

- Part No.
- Size(P,M): See ①
- Finish
 (blank): Tin over Nickel
 G: Gold over Nickel (1u")
 G15: Gold over Nickel (15u")
 G20: Gold over Nickel (20u")
 G30: Gold over Nickel (30u")

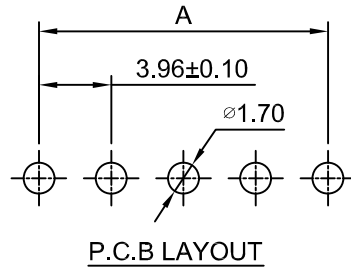
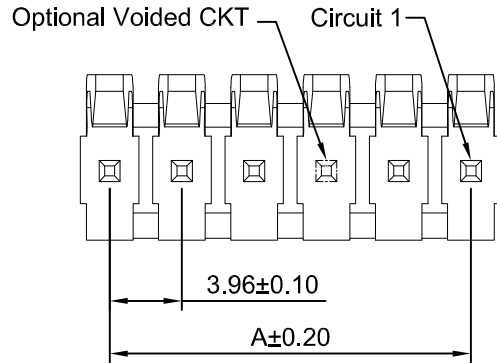

SPECIFICATIONS:
 Current Rating: 7A AC,DC
 Voltage Rating: 250V AC,DC
 Temperature Range: -25°C ~ +85°C
 Contact Resistance: 10mΩ Max
 Insulation Resistance: 1000MΩ Min
 Withstanding Voltage: 1500V AC/minute
 Pin Material: Brass/Tin over Nickel
 Material: Nylon 66,UL94V-0(Black)

Ordering Information & Dimensions

Circuits	Dimensions(mm)		Circuits	Dimensions(mm)	
	A	B		A	B
2P	3.96	7.16	14P	51.48	54.68
3P	7.92	11.12	15P	55.44	58.64
4P	11.88	15.08	16P	59.40	62.60
5P	15.84	19.04	17P	63.36	66.56
6P	19.80	23.00	18P	67.32	70.52
7P	23.76	26.96	19P	71.28	74.48
8P	27.72	30.92	20P	75.24	78.44
9P	31.68	34.88	21P	79.20	82.40
10P	35.64	38.84	22P	83.16	86.36
11P	39.60	42.80	23P	87.12	90.32
12P	43.56	46.76	24P	91.08	94.28
13P	47.52	50.72			

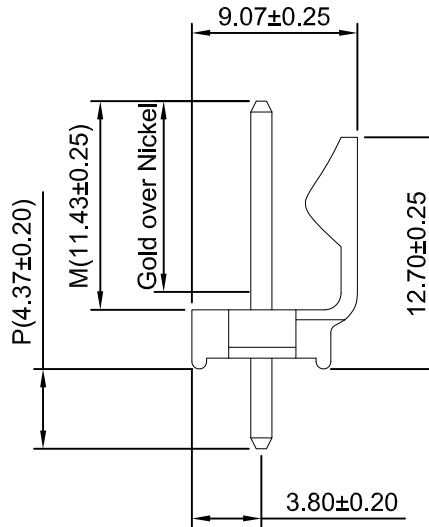
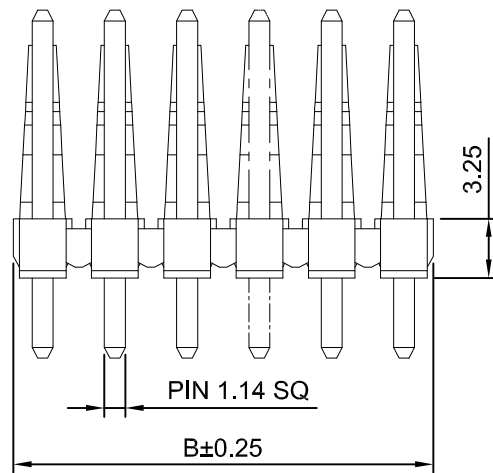

Note: ①

PART NO.	P(mm)	M(mm)	PART NO.	P(mm)	M(mm)
P44M114	4.37	11.43	P115M114	11.53	11.43
P32M114	3.18	11.43	P32M133	3.18	13.28
P25M133	2.51	13.28	P74M114	7.42	11.43
P44M122	4.37	12.19	P123M122	12.34	12.19

深圳市华德共创科技有限公司
 SHENZHEN HUADE CO-CREATE TECHNOLOGY CO.,LTD
 TEL : 0755-27129737 FAX : 0755-29940187

-TOLERANCES- UNLESS OTHERWISE SPECIFIED 公差参数表			TITLE: 3.96mm Pitch 产品名称: 180° Wafer	
X.X ±0.30	X.X° ±3°	APPD: 核准: XIE	PART NO: HDGC3961WVC-XP 产品编号:	
X.XX ±0.30	X.XX° ±2°	CHECK: 校对: WANG	DATE	SCALE
X.XXX ±0.10	X.XXX° ±1°	DRAW: 绘图: WANG	2013-12-06	2.5:1
			UNIT	CODE NUMBER
			mm	A008

修订 REV	标记 MARK	修改摘要 REVISION DESCRIPTION	签名 SIGNATURE	日期 DATE
AO		NEW RELEASE	WANG	2013-12-06

Ordering Information:
 HDGC3961WRC-XP - **** - ***
 1 2 3

- 1.Part No.
- 2.Size(P,M,Y):See ①
- 3.Finish
 (blank):Tin over Nickel
 G:Gold over Nickel (1u")
 G15:Gold over Nickel(15u")
 G20:Gold over Nickel(20u")
 G30:Gold over Nickel(30u")

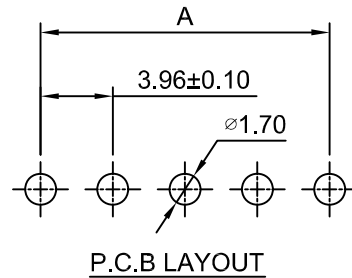
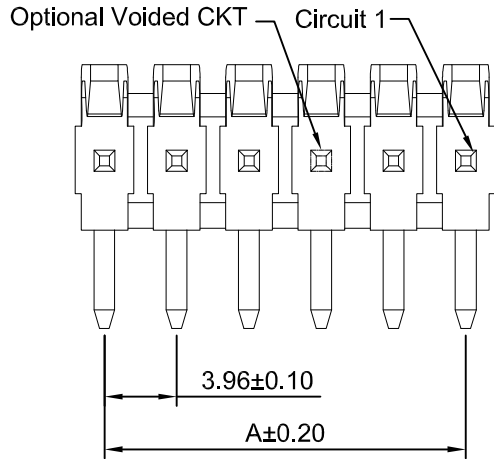

SPECIFICATIONS:

Current Rating: 7A AC,DC
 Voltage Rating: 250V AC,DC
 Temperature Range: -25°C ~ +85°C
 Contact Resistance: 10mΩ Max
 Insulation Resistance: 1000MΩ Min
 Withstanding Voltage: 1500V AC/minute
 Pin Material: Brass/Tin over Nickel
 Material: Nylon 66,UL94V-0(Black)

Ordering Information & Dimensions

Circuits	Dimensions(mm)		Circuits	Dimensions(mm)	
	A	B		A	B
2P	3.96	7.16	14P	51.48	54.68
3P	7.92	11.12	15P	55.44	58.64
4P	11.88	15.08	16P	59.40	62.60
5P	15.84	19.04	17P	63.36	66.56
6P	19.80	23.00	18P	67.32	70.52
7P	23.76	26.96	19P	71.28	74.48
8P	27.72	30.92	20P	75.24	78.44
9P	31.68	34.88	21P	79.20	82.40
10P	35.64	38.84	22P	83.16	86.36
11P	39.60	42.80	23P	87.12	90.32
12P	43.56	46.76	24P	91.08	94.28
13P	47.52	50.72			

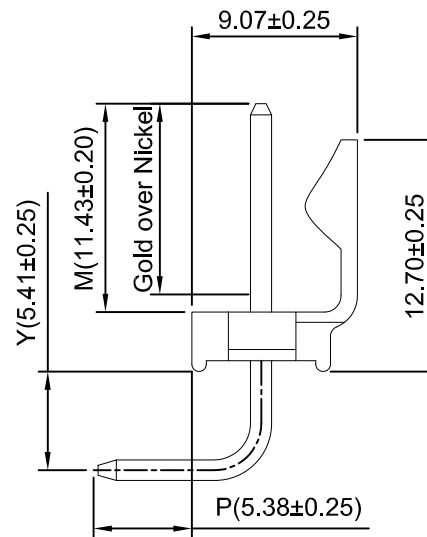
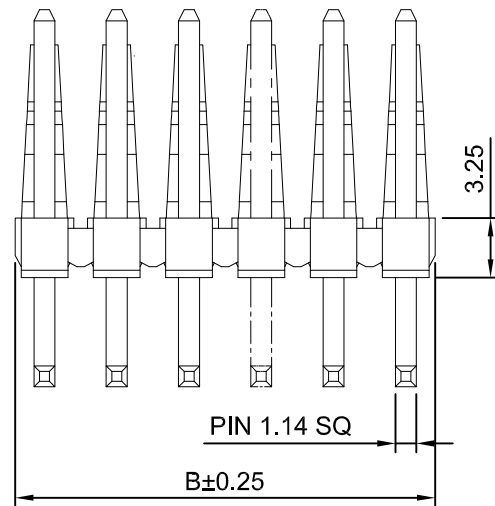

Note: ①

PART NO.	P(mm)	M(mm)	Y(mm)	PART NO.	P(mm)	M(mm)	Y(mm)
P54M114Y54	5.38	11.43	5.41	P35M114Y56	3.45	11.43	5.61
P35M133Y54	3.45	13.28	5.41	P35M114Y54	3.45	11.43	5.41
P54M133Y55	5.38	13.28	5.51	P47M114Y54	4.69	11.43	5.41
P150M127Y54	15.04	12.67	5.41				



深圳市华德共创科技有限公司

SHENZHEN HUADE CO-CREATE TECHNOLOGY CO.,LTD

TEL : 0755-27129737 FAX : 0755-29940187

-TOLERANCES- UNLESS OTHERWISE SPECIFIED 公差参数表					TITLE: 3.96mm Pitch 产品名称: 180° Wafer					
X.X	±0.30	X.X°	±3°	APPD: 核准:	XIE		PART NO: 产品编号: HDGC3961WRC-XP			
X.XX	±0.30	X.XX°	±2°	CHECK: 校对:	WANG		DATE	SCALE	UNIT	CODE NUMBER
X.XXX	±0.10	X.XXX°	±1°	DRAW: 绘图:	WANG		2013-12-06	2.5:1	mm	A008