

修订 REV	标记 MARK	修改摘要 REVISION DESCRIPTION	签名 SIGNATURE	日期 DATE
A0		NEW RELEASE	WANG	2013-08-20

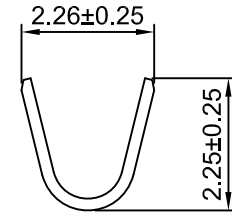

SEC:A-A

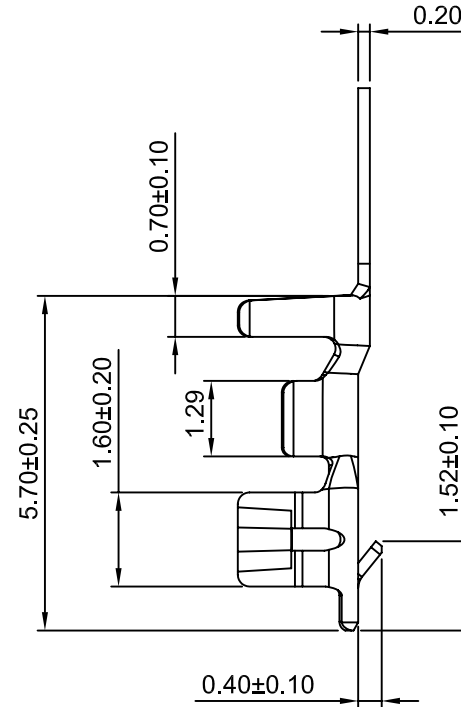
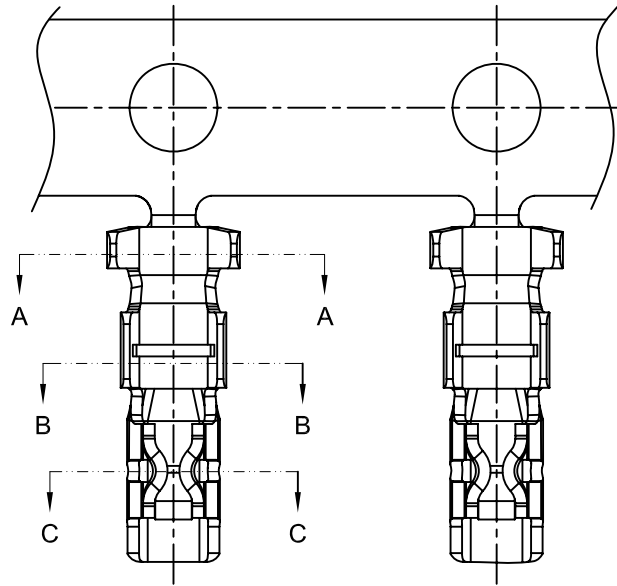
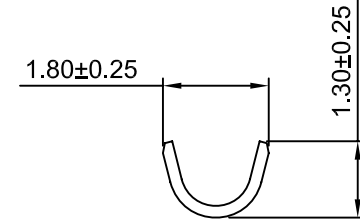

SEC:B-B

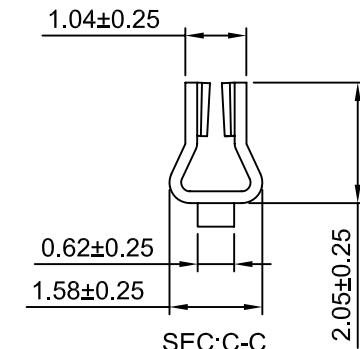

SEC:C-C

Ordering information & Specifications

Unit:mm

Part No	Wire Range	Insulation O.D.	Material	Finish	Qty/reel
HDGC2011-TP	AWG#22-#28	1.45mm(max)	Phosphor Bronze	Tin over Nickel	10,000 PCS
HDGC2011-GP	AWG#22-#28	1.45mm(max)	Phosphor Bronze	Gold over Nickel	10,000 PCS

Optional Gold plating available but MOQ requested



深圳市华德共创科技有限公司

Shenzhen Huade co-create Technology Co.,LTD

TEL : 0755-27129737 FAX : 0755-29940187

-TOLERANCES- UNLESS OTHERWISE SPECIFIED 公差参数表					TITLE: 产品名称: 2.00mm Pitch Crimp Terminal			
X.X	±0.30	X.X°	±3°	APPD: 核准: XIE	PART NO: 产品编号: HDGC2011-T			
X.XX	±0.30	X.XX°	±2°	CHECK: 校对: WANG	DATE	SCALE	UNIT	CODE NUMBER
X.XXX	±0.10	X.XXX°	±1°	DRAW: 绘图: WANG	2013-08-20	8:1	mm	A008

修订 REV	标记 MARK	修改摘要 REVISION DESCRIPTION	签名 SIGNATURE	日期 DATE
AO		NEW RELEASE	WANG	2013-08-20

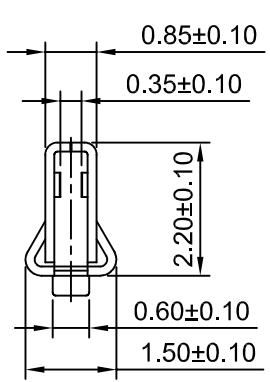
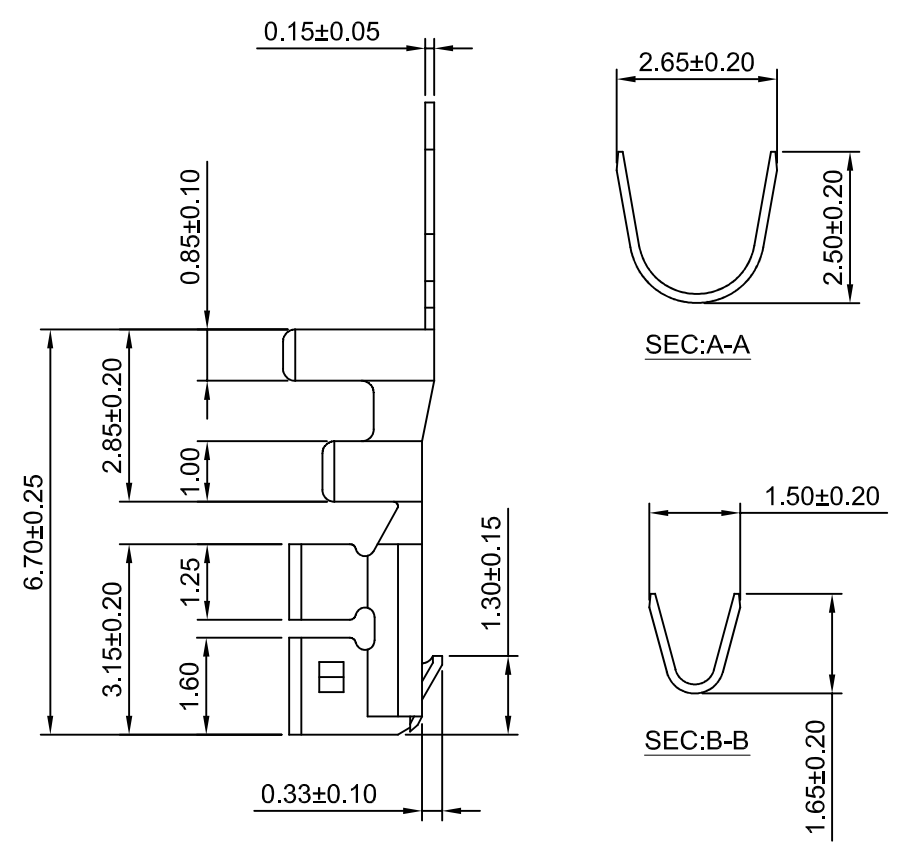
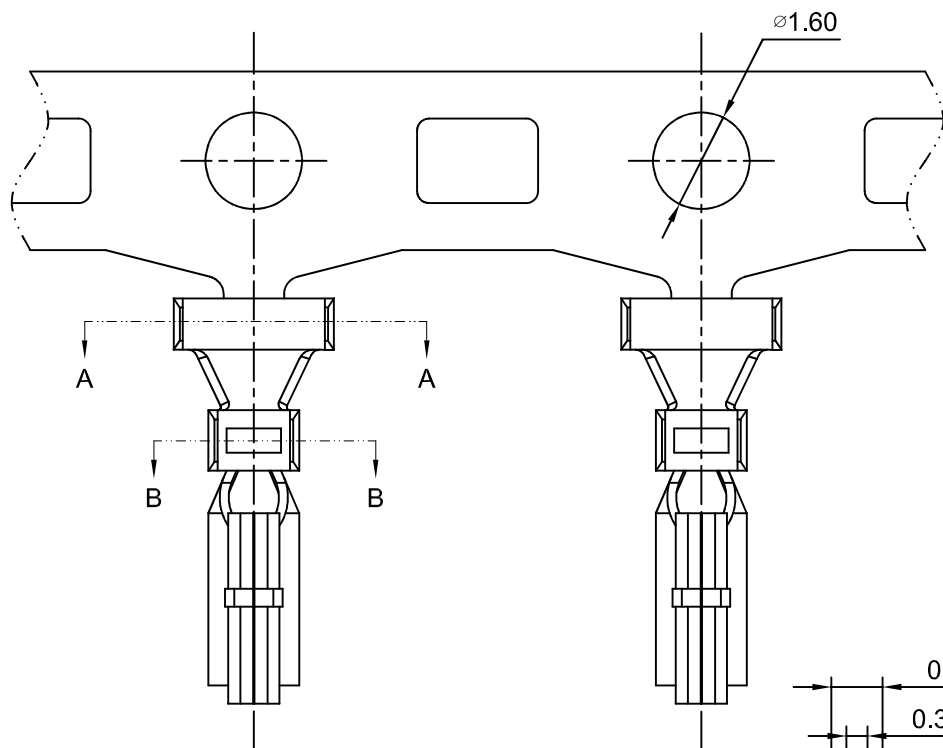

Ordering information & Specifications

Unit:mm

Part No	Wire Range	Insultion O.D.	Material	Finish	Qty/reel
HDGC2011-TP-A	AWG#22-#28	1.45mm(max)	Phosphor Bronze	Tin over Nickel	10,000 PCS
HDGC2011-GP-A	AWG#22-#28	1.45mm(max)	Phosphor Bronze	Gold over Nickel	10,000 PCS

Optional Gold plating available but MOQ requested

深圳市华德共创科技有限公司
Shenzhen Huade co-create Technology Co.,LTD
TEL : 0755-27129737 FAX : 0755-29940187

-TOLERANCES- UNLESS OTHERWISE SPECIFIED 公差参数表						TITLE: 2.00mm Pitch 产品名称: Crimp Terminal			
X.X	±0.30	X.X°	±3°	APPD: 核准:	XIE	PART NO: 产品编号: HDGC2011-T-A			
X.XX	±0.30	X.XX°	±2°	CHECK: 校对:	WANG	DATE	SCALE	UNIT	CODE NUMBER
X.XXX	±0.10	X.XXX°	±1°	DRAW: 绘图:	WANG	2013-08-20	8:1	mm	A008

修订 REV	标记 MARK	修改摘要 REVISION DESCRIPTION	签名 SIGNATURE	日期 DATE
AO		NEW RELEASE	WANG	2013-08-20

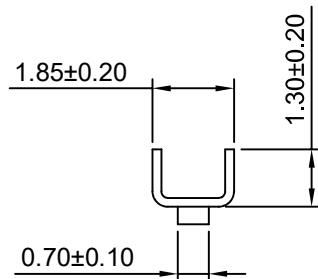
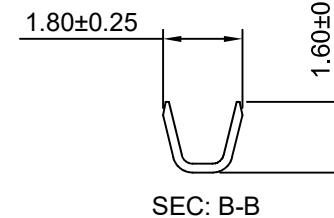
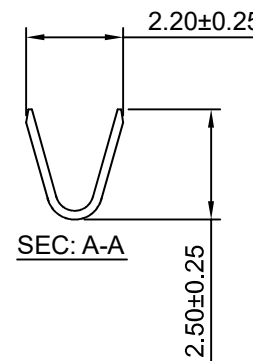
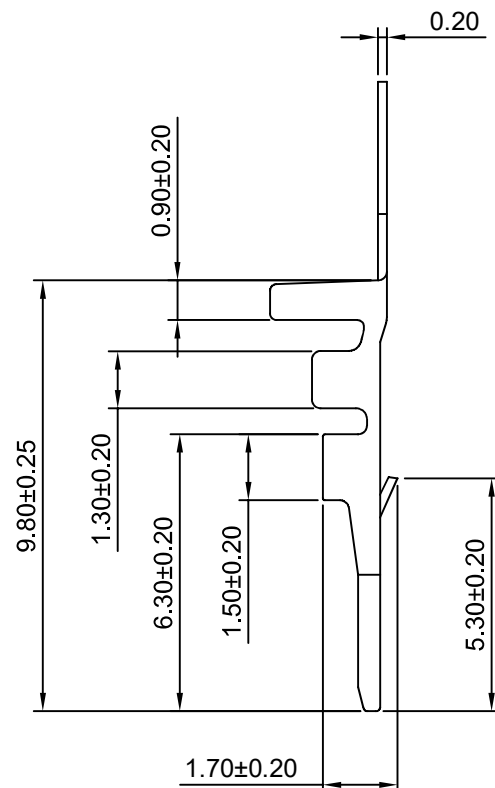
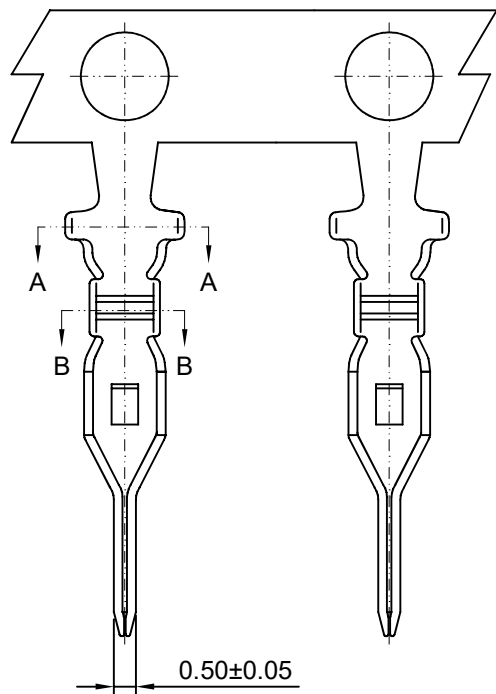

Ordering information & Specifications

Unit:mm

Part No	Wire Range	Insultion O.D.	Material	Finish	Qty/reel
HDGC2011M-TP	AWG#24-#28	1.45mm(max)	Phosphor Bronze	Tin over Nickel	10,000 PCS
HDGC2011M-GP	AWG#24-#28	1.45mm(max)	Phosphor Bronze	Gold over Nickel	10,000 PCS

Optional Gold plating available but MOQ requested



深圳市华德共创科技有限公司

Shenzhen Huade co-create Technology Co.,LTD

TEL : 0755-27129737 FAX : 0755-29940187

-TOLERANCES- UNLESS OTHERWISE SPECIFIED 公差参数表						TITLE: 2.00mm Pitch 产品名称: Crimp Terminal			
X.X	±0.30	X.X°	±3°	APPD: 核准:	XIE	PART NO: 产品编号: HDGC2011M-T			
X.XX	±0.30	X.XX°	±2°	CHECK: 校对:	WANG	DATE	SCALE	UNIT	CODE NUMBER
X.XXX	±0.10	X.XXX°	±1°	DRAW: 绘图:	WANG	2013-08-20	6:1	mm	A008

修订 REV	标记 MARK	修改摘要 REVISION DESCRIPTION	签名 SIGNATURE	日期 DATE
AO		NEW RELEASE	WANG	2013-08-20

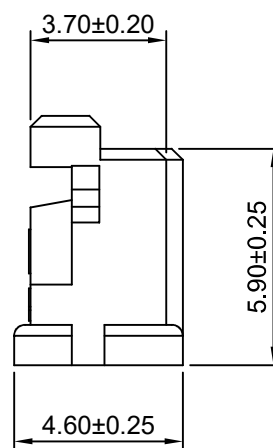
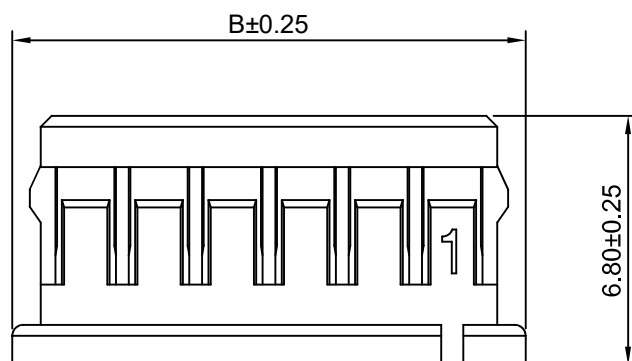
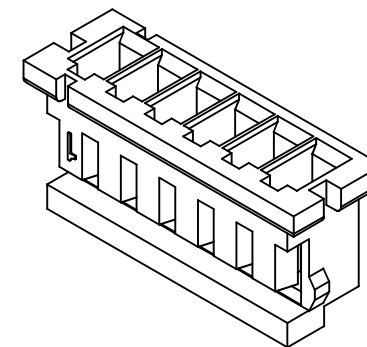
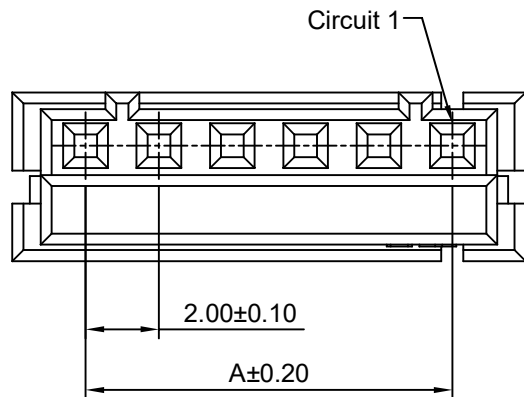

Ordering Information & Dimensions

Circuits	Dimensions(mm)		Circuits	Dimensions(mm)	
	A	B		A	B
2P	2.00	6.00	9P	16.00	20.00
3P	4.00	8.00	10P	18.00	22.00
4P	6.00	4.00	11P	20.00	24.00
5P	8.00	12.00	12P	22.00	26.00
6P	10.00	14.00	13P	24.00	28.00
7P	12.00	16.00	14P	26.00	30.00
8P	14.00	18.00	15P	28.00	32.00

SPECIFICATIONS:

Current Rating: 3A AC,DC
Voltage Rating: 250V AC,DC
Temperature Range: -25°C ~ +85°C
Contact Resistance: 30mΩ Max.
Insulation Resistance: 1000MΩ Min.
Withstanding Voltage: 650V AC/minute
Material: Nylon 66,UL94V-0 (Black)



深圳市华德共创科技有限公司

Shenzhen Huade co-create Technology Co.,LTD

TEL : 0755-27129737 FAX : 0755-29940187

-TOLERANCES- UNLESS OTHERWISE SPECIFIED 公差参数表						TITLE: 产品名称: 2.00mm Pitch Housing			
X.X	±0.30	X.X°	±3°	APPD: 核准:	XIE	PART NO: 产品编号: HDGC2011H-XP			
X.XX	±0.30	X.XX°	±2°	CHECK: 校对:	WANG	DATE	SCALE	UNIT	CODE NUMBER
X.XXX	±0.10	X.XXX°	±1°	DRAW: 绘图:	WANG	2013-08-20	5:1	mm	A008

修订 REV	标记 MARK	修改摘要 REVISION DESCRIPTION	签名 SIGNATURE	日期 DATE
AO		NEW RELEASE	WANG	2013-08-20

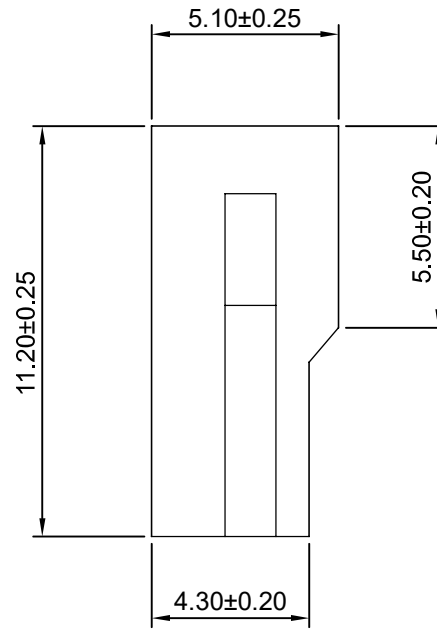
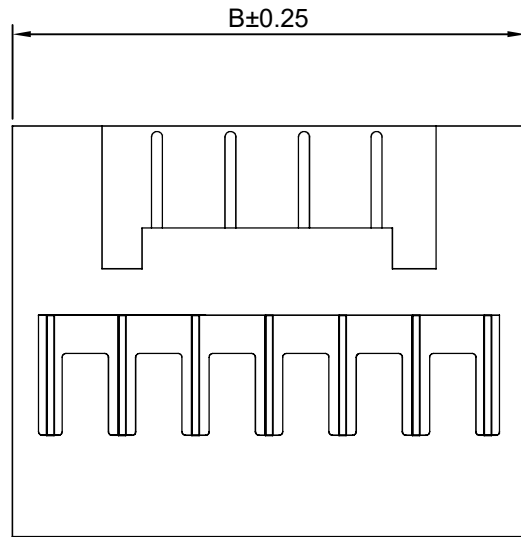
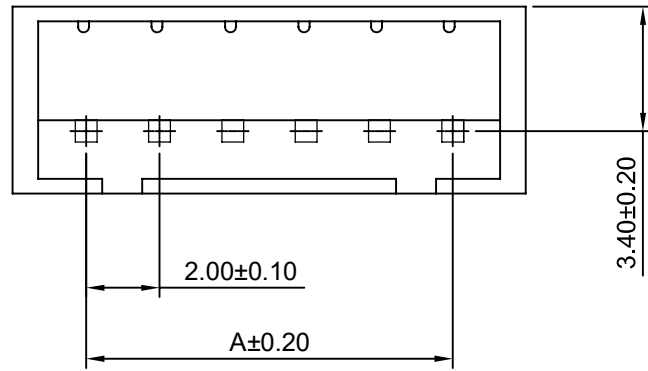
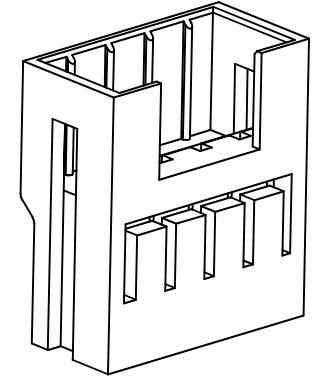

Ordering Information & Dimensions

Circuits	Dimensions(mm)		Circuits	Dimensions(mm)	
	A	B		A	B
2P	2.00	6.00	9P	16.00	20.00
3P	4.00	8.00	10P	18.00	22.00
4P	6.00	10.00	11P	20.00	24.00
5P	8.00	12.00	12P	22.00	26.00
6P	10.00	14.00	13P	24.00	28.00
7P	12.00	16.00	14P	26.00	30.00
8P	14.00	18.00	15P	28.00	32.00

SPECIFICATIONS:

Current Rating: 3A AC,DC
Voltage Rating: 250V AC,DC
Temperature Range: -25°C ~ +85°C
Contact Resistance: 30mΩ Max.
Insulation Resistance: 1000MΩ Min.
Withstanding Voltage: 650V AC/minute
Material: Nylon 66,UL94V-0 (Black)



深圳市华德共创科技有限公司

Shenzhen Huade co-create Technology Co.,LTD
TEL : 0755-27129737 FAX : 0755-29940187

-TOLERANCES- UNLESS OTHERWISE SPECIFIED 公差参数表						TITLE: 产品名称: 2.00mm Pitch Housing			
X.X	±0.30	X.X°	±3°	APPD: 核准:	XIE	PART NO: 产品编号: HDGC2011HM-XP			
X.XX	±0.30	X.XX°	±2°	CHECK: 校对:	WANG	DATE	SCALE	UNIT	CODE NUMBER
X.XXX	±0.10	X.XXX°	±1°	DRAW: 绘图:	WANG	2013-08-20	5:1	mm	A008

修订 REV	标记 MARK	修改摘要 REVISION DESCRIPTION	签名 SIGNATURE	日期 DATE
AO		NEW RELEASE	WANG	2013-08-20

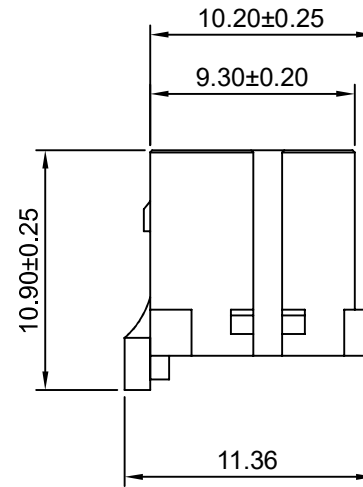
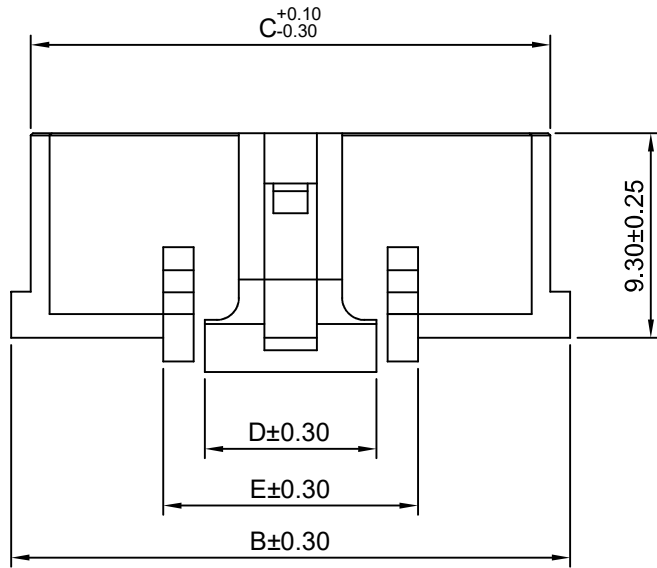
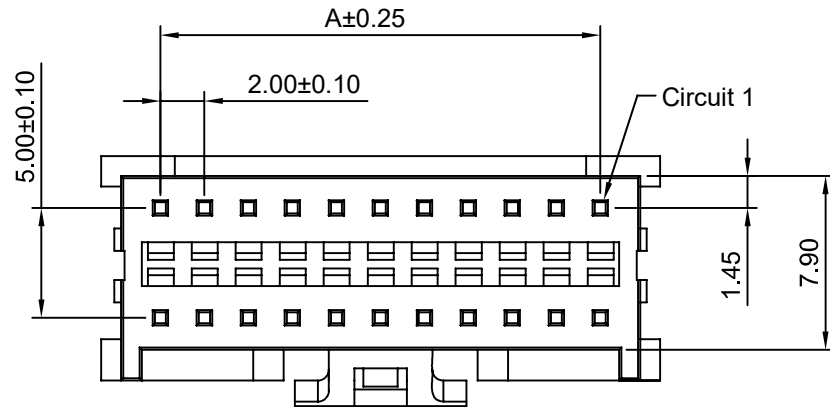

Ordering Information & Dimensions

Circuits	Dimensions(mm)				
	A	B	C	D	E
2x4P	6.00	11.40	9.60	4.70	8.40
2x5P	8.00	13.40	11.60	4.70	8.40
2x6P	10.00	15.40	13.60	7.80	11.60
2x7P	12.00	17.40	15.60	7.80	11.60
2x8P	14.00	19.40	17.60	7.80	11.60
2x9P	16.00	21.40	19.60	7.80	11.60
2x10P	18.00	23.40	21.60	7.80	11.60
2x11P	20.00	25.40	23.60	7.80	11.60
2x12P	22.00	27.40	25.60	7.80	11.60
2x13P	24.00	29.40	27.60	7.80	11.60
2x14P	26.00	31.40	29.60	7.80	11.60
2x15P	28.00	33.40	31.60	7.80	11.60
2x16P	30.00	35.40	33.60	7.80	11.60
2x17P	32.00	37.40	35.60	7.80	11.60
2x18P	34.00	39.40	37.60	7.80	11.60
2x19P	36.00	41.40	39.60	7.80	11.60
2x20P	38.00	43.40	41.60	7.80	11.60

SPECIFICATIONS:
 Current Rating: 3A AC,DC
 Voltage Rating: 250V AC,DC
 Temperature Range: -25°C ~ +85°C
 Contact Resistance: 20mΩ Max.
 Insulation Resistance: 1000MΩ Min.
 Withstanding Voltage: 1000V AC/minute
 Material: Nylon66 UL94V-0(White)



深圳市华德共创科技有限公司

Shenzhen Huade co-create Technology Co.,LTD
 TEL : 0755-27129737 FAX : 0755-29940187

-TOLERANCES- UNLESS OTHERWISE SPECIFIED 公差参数表						TITLE: 产品名称: 2.00mm Pitch Housing			
X.X	±0.30	X.X°	±3°	APPD: 核准:	XIE	PART NO: 产品编号: HDGC2011HA-2xXP			
X.XX	±0.30	X.XX°	±2°	CHECK: 校对:	WANG	DATE	SCALE	UNIT	CODE NUMBER
X.XXX	±0.10	X.XXX°	±1°	DRAW: 绘图:	WANG	2013-08-20	3:1	mm	A008

修订 REV	标记 MARK	修改摘要 REVISION DESCRIPTION	签名 SIGNATURE	日期 DATE
AO		NEW RELEASE	WANG	2013-08-20

Ordering Information:

HDGC2011WV-XP - **
1 2

- Part No.
- Finish:
(blank): Tin over Nickel
G: Gold over Nickel

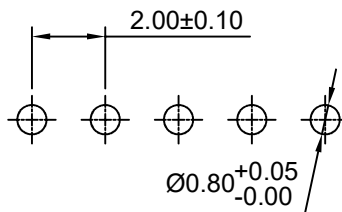
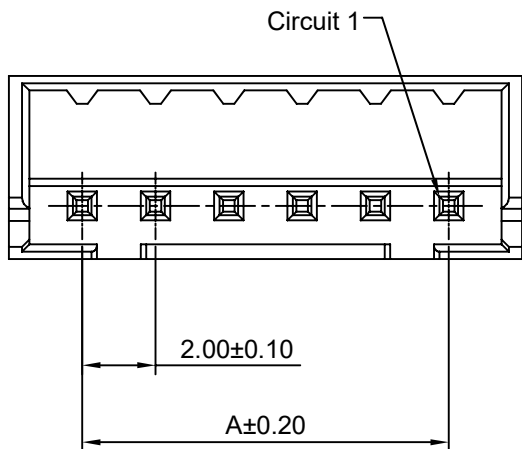

P.C.B LAYOUT

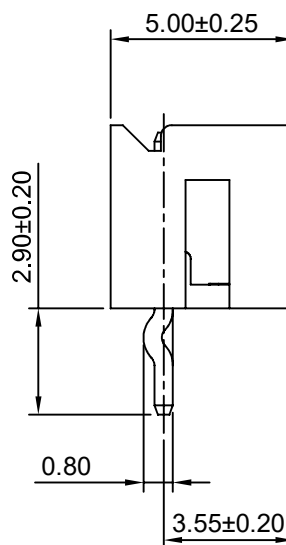
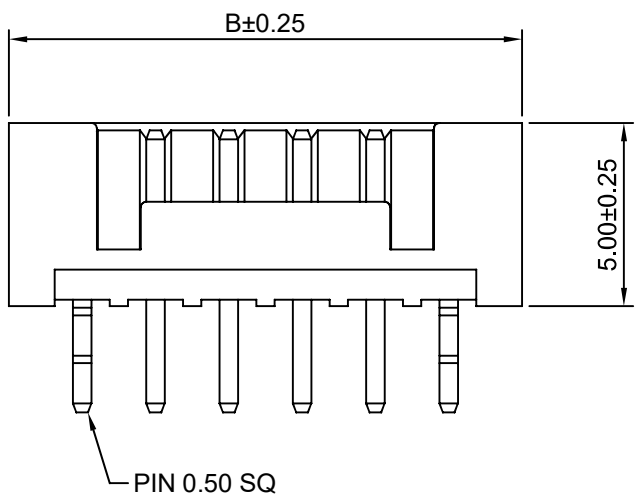
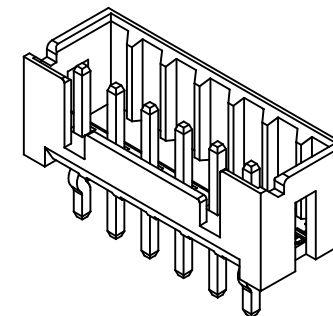

Ordering Information & Dimensions

Circuits	Dimensions(mm)		Circuits	Dimensions(mm)	
	A	B		A	B
2P	2.00	6.00	9P	16.00	20.00
3P	4.00	8.00	10P	18.00	22.00
4P	6.00	10.00	11P	20.00	24.00
5P	8.00	12.00	12P	22.00	26.00
6P	10.00	14.00	13P	24.00	28.00
7P	12.00	16.00	14P	26.00	30.00
8P	14.00	18.00	15P	28.00	32.00

SPECIFICATIONS:

Current Rating: 3A AC,DC
Voltage Rating: 250V AC,DC
Temperature Range: -25C ~ +85°C
Contact Resistance: 30mΩ Max.
Insulation Resistance: 1000MΩ Min.
Withstanding Voltage: 650V AC/minute
Pin Material: Brass/Tin over Nickel
Material: Nylon 66,UL94V-0(Black)



深圳市华德共创科技有限公司

Shenzhen Huade co-create Technology Co.,LTD
TEL : 0755-27129737 FAX : 0755-29940187

-TOLERANCES- UNLESS OTHERWISE SPECIFIED 公差参数表				TITLE: 产品名称: 2.00mm Pitch 180° Wafer	
X.X	±0.30	X.X°	±3°	APPD: 核准:	XIE
X.XX	±0.30	X.XX°	±2°	CHECK: 校对:	WANG
X.XXX	±0.10	X.XXX°	±1°	DRAW: 绘图:	WANG
PART NO: 产品编号:		HDGC2011WV-XP			
DATE	SCALE	UNIT	CODE NUMBER		
2013-08-20	5:1	mm	A008		

修订 REV	标记 MARK	修改摘要 REVISION DESCRIPTION	签名 SIGNATURE	日期 DATE
AO		NEW RELEASE	WANG	2013-08-20

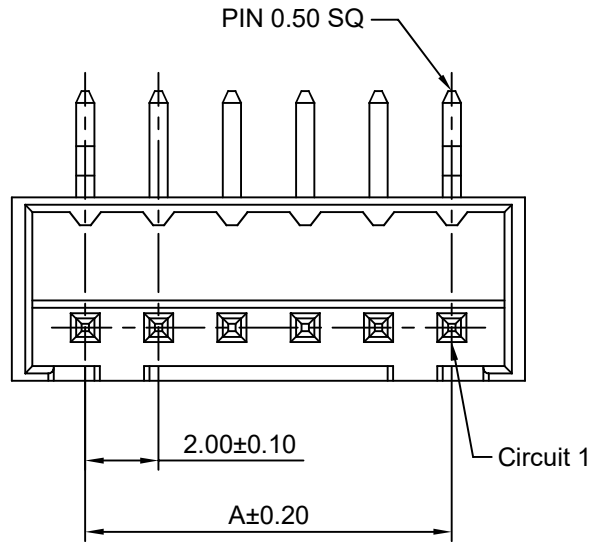

Ordering Information:

HDGC2011WR-XP - **
1 2

- 1.Part No.
- 2.Finish:
(blank):Tin over Nickel
G:Gold over Nickel

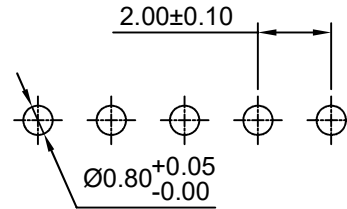

P.C.B LAYOUT

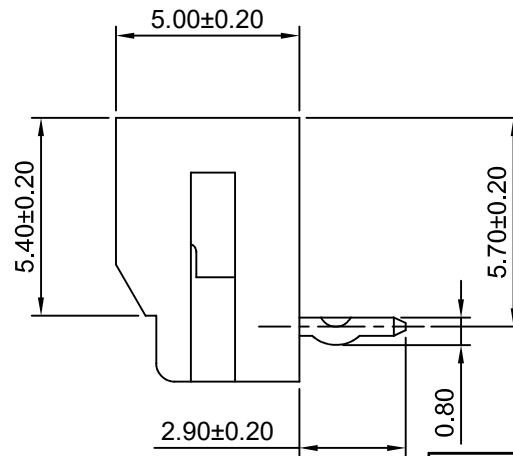
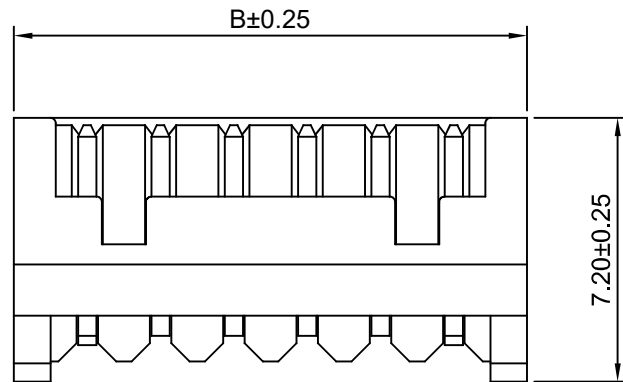
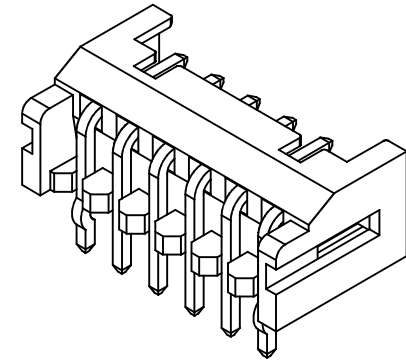

Ordering Information & Dimensions

Circuits	Dimensions(mm)		Circuits	Dimensions(mm)	
	A	B		A	B
2P	2.00	6.00	9P	16.00	20.00
3P	4.00	8.00	10P	18.00	22.00
4P	6.00	10.00	11P	20.00	24.00
5P	8.00	12.00	12P	22.00	26.00
6P	10.00	14.00	13P	24.00	28.00
7P	12.00	16.00	14P	26.00	30.00
8P	14.00	18.00	15P	28.00	32.00

SPECIFICATIONS:

Current Rating: 3A AC,DC
Voltage Rating: 250V AC,DC
Temperature Range: -25C ~ +85°C
Contact Resistance: 30mΩ Max.
Insulation Resistance: 1000MΩ Min.
Withstanding Voltage: 650V AC/minute
Pin Material: Brass/Tin over Nickel
Material: Nylon 66,UL94V-0(Black)



深圳市华德共创科技有限公司

Shenzhen Huade co-create Technology Co.,LTD
TEL : 0755-27129737 FAX : 0755-29940187

-TOLERANCES- UNLESS OTHERWISE SPECIFIED 公差参数表				TITLE: 产品名称: 2.00mm Pitch 90° Wafer	
X.X	±0.30	X.X°	±3°	APPD: 核准:	XIE
X.XX	±0.30	X.XX°	±2°	CHECK: 校对:	WANG
X.XXX	±0.10	X.XXX°	±1°	DRAW: 绘图:	WANG
PART NO: 产品编号:		HDGC2011WR-XP			
DATE	SCALE	UNIT	CODE NUMBER		
2013-08-20	5:1	mm	A008		

修订 REV	标记 MARK	修改摘要 REVISION DESCRIPTION	签名 SIGNATURE	日期 DATE
AO		NEW RELEASE	WANG	2013-08-20

Ordering Information:
 HDGC2011WV-S-XP - **
 1 2

- Part No.
- Finish:
 (blank): Tin over Nickel
 G: Gold over Nickel

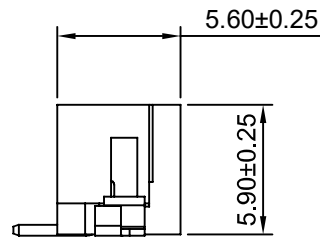
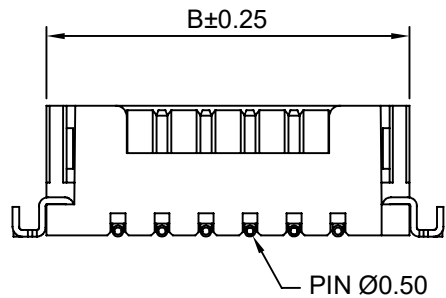
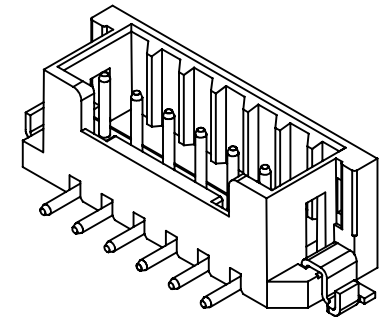
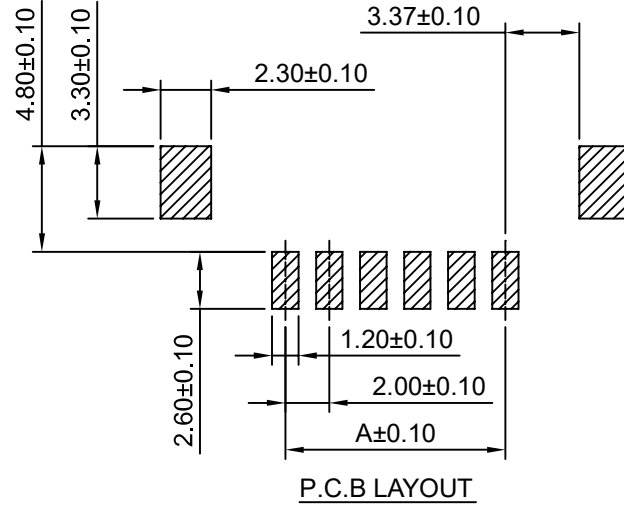
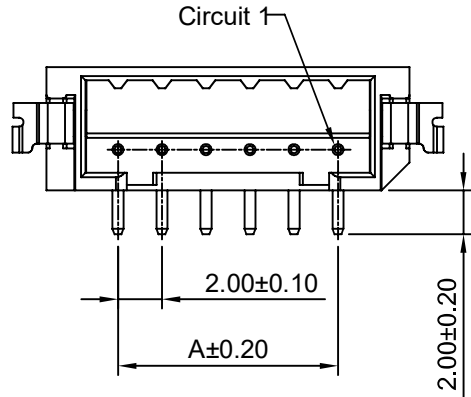

Ordering Information & Dimensions

Circuits	Dimensions(mm)		Circuits	Dimensions(mm)	
	A	B		A	B
2P	2.00	8.50	9P	16.00	22.50
3P	4.00	10.50	10P	18.00	24.50
4P	6.00	12.50	11P	20.00	26.50
5P	8.00	14.50	12P	22.00	28.50
6P	10.00	16.50	13P	24.00	30.50
7P	12.00	18.50	14P	26.00	32.50
8P	14.00	20.50	15P	28.00	34.50

SPECIFICATIONS:

Current Rating: 3A AC,DC
 Voltage Rating: 250V AC,DC
 Temperature Range: -25°C ~ +85°C
 Contact Resistance: 30mΩ Max.
 Insulation Resistance: 1000MΩ Min.
 Withstanding Voltage: 650V AC/minute
 Pin Material: Brass/Tin over Nickel
 Solder Tabs: Brass/Tin over Nickel
 Material: Nylon 6T,UL94V-0(Ivory)



深圳市华德共创科技有限公司

Shenzhen Huade co-create Technology Co.,LTD
 TEL : 0755-27129737 FAX : 0755-29940187

-TOLERANCES- UNLESS OTHERWISE SPECIFIED 公差参数表						TITLE: 2.00mm Pitch 产品名称: 180° Wafer			
X.X	±0.30	X.X°	±3°	APPD: 核准:	XIE	PART NO: 产品编号: HDGC2011WV-S-XP			
X.XX	±0.30	X.XX°	±2°	CHECK: 校对:	WANG	DATE	SCALE	UNIT	CODE NUMBER
X.XXX	±0.10	X.XXX°	±1°	DRAW: 绘图:	WANG	2013-08-20	3:1	mm	A008

修订 REV	标记 MARK	修改摘要 REVISION DESCRIPTION	签名 SIGNATURE	日期 DATE
AO		NEW RELEASE	WANG	2013-08-20

Ordering Information:
HDGC2011WR-S-XP - **

- 1.Part No.
2.Finish:
(blank):Tin over Nickel
G:Gold over Nickel

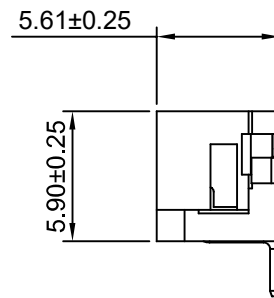
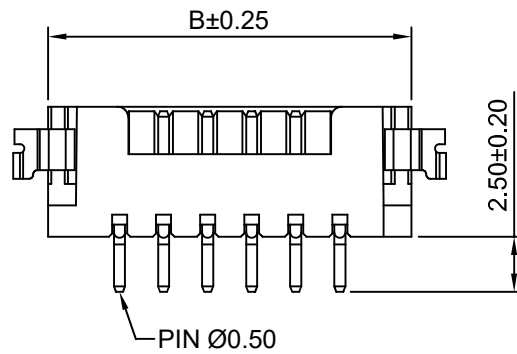
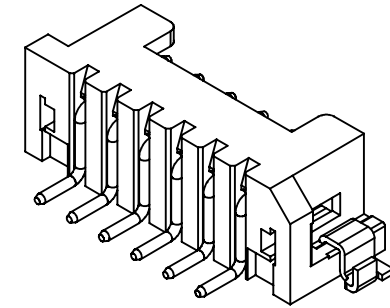
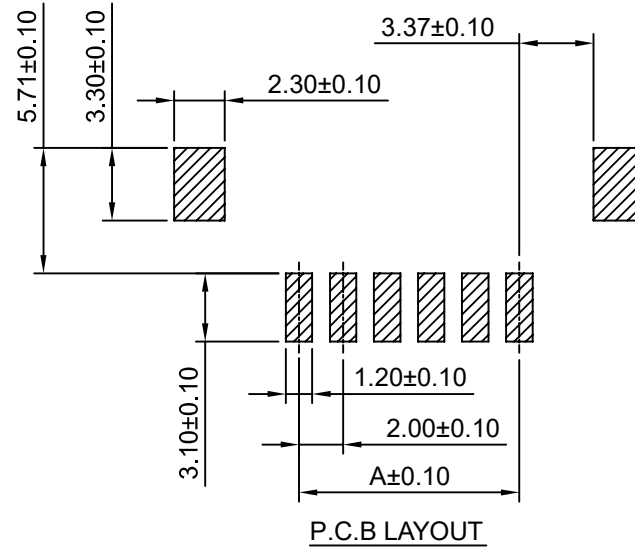
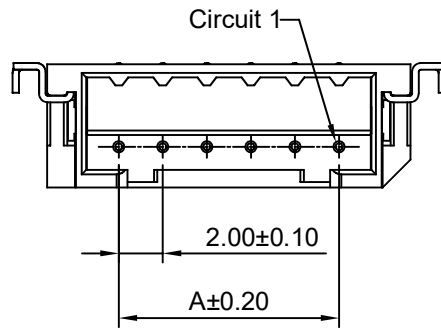

Ordering Information & Dimensions

Circuits	Dimensions(mm)		Circuits	Dimensions(mm)	
	A	B		A	B
2P	2.00	8.50	9P	16.00	22.50
3P	4.00	10.50	10P	18.00	24.50
4P	6.00	12.50	11P	20.00	26.50
5P	8.00	14.50	12P	22.00	28.50
6P	10.00	16.50	13P	24.00	30.50
7P	12.00	18.50	14P	26.00	32.50
8P	14.00	20.50	15P	28.00	34.50

SPECIFICATIONS:

Current Rating: 3A AC,DC
Voltage Rating: 250V AC,DC
Temperature Range: -25°C ~ +85°C
Contact Resistance: 30mΩ Max.
Insulation Resistance: 1000MΩ Min.
Withstanding Voltage: 650V AC/minute
Pin Material: Brass/Tin over Nickel
Solder Tabs: Brass/Tin over Nickel
Material: Nylon 6T,UL94V-0(Ivory)



深圳市华德共创科技有限公司

Shenzhen Huade co-create Technology Co.,LTD
TEL : 0755-27129737 FAX : 0755-29940187

-TOLERANCES- UNLESS OTHERWISE SPECIFIED 公差参数表				TITLE: 产品名称 : 2.00mm Pitch 90° Wafer	
X.X	±0.30	X.X°	±3°	APPD: 核准:	XIE
X.XX	±0.30	X.XX°	±2°	CHECK: 校对:	WANG
X.XXX	±0.10	X.XXX°	±1°	DRAW: 绘图:	WANG
PART NO: 产品编号 :		HDGC2011WR-S-XP			
DATE	SCALE	UNIT	CODE NUMBER		
2013-08-20	3:1	mm	A008		

修订 REV	标记 MARK	修改摘要 REVISION DESCRIPTION	签名 SIGNATURE	日期 DATE
AO		NEW RELEASE	WANG	2013-08-20

Ordering Information:
HDGC2011WV-S-F-XP - **
1 2

- 1.Part No.
2.Finish:
(blank):Tin over Nickel
G:Gold over Nickel

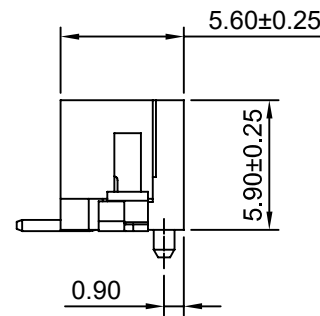
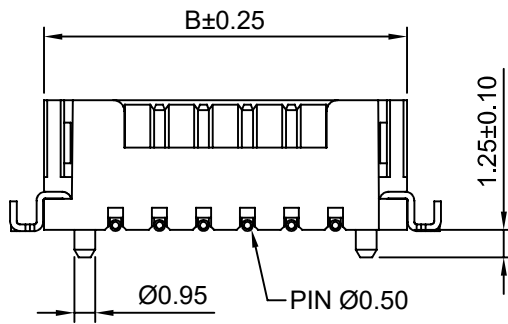
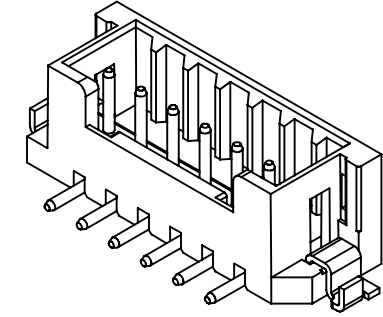
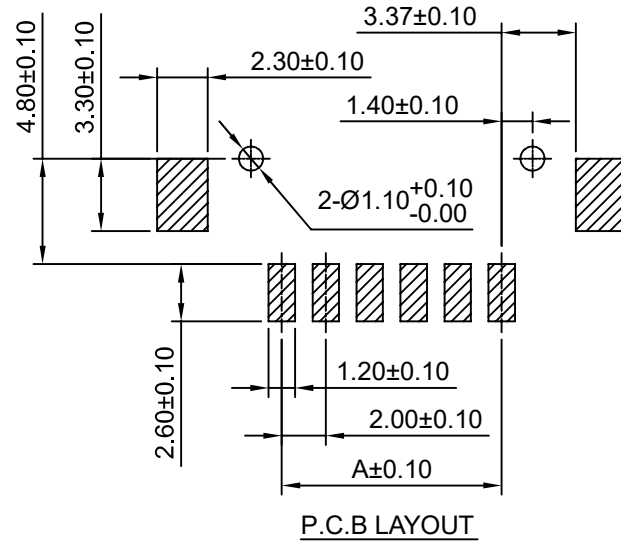
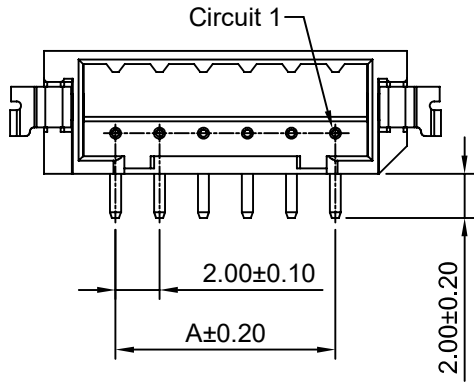

Ordering Information & Dimensions

Circuits	Dimensions(mm)		Circuits	Dimensions(mm)	
	A	B		A	B
2P	2.00	8.50	9P	16.00	22.50
3P	4.00	10.50	10P	18.00	24.50
4P	6.00	12.50	11P	20.00	26.50
5P	8.00	14.50	12P	22.00	28.50
6P	10.00	16.50	13P	24.00	30.50
7P	12.00	18.50	14P	26.00	32.50
8P	14.00	20.50	15P	28.00	34.50

SPECIFICATIONS:

Current Rating: 3A AC,DC
Voltage Rating: 250V AC,DC
Temperature Range: -25°C ~ +85°C
Contact Resistance: 30mΩ Max.
Insulation Resistance: 1000MΩ Min.
Withstanding Voltage: 650V AC/minute
Pin Material: Brass/Tin over Nickel
Solder Tabs: Brass/Tin over Nickel
Material: Nylon 6T,UL94V-0(Ivory)



深圳市华德共创科技有限公司

Shenzhen Huade co-create Technology Co.,LTD
TEL : 0755-27129737 FAX : 0755-29940187

-TOLERANCES- UNLESS OTHERWISE SPECIFIED 公差参数表						TITLE: 2.00mm Pitch 产品名称: 180° Wafer			
X.X	±0.30	X.X°	±3°	APPD: 核准:	XIE	PART NO: 产品编号: HDGC2011WV-S-F-XP			
X.XX	±0.30	X.XX°	±2°	CHECK: 校对:	WANG	DATE	SCALE	UNIT	CODE NUMBER
X.XXX	±0.10	X.XXX°	±1°	DRAW: 绘图:	WANG	2013-08-20	3:1	mm	A008

修订 REV	标记 MARK	修改摘要 REVISION DESCRIPTION	签名 SIGNATURE	日期 DATE
AO		NEW RELEASE	WANG	2013-08-20

Ordering Information:

HDGC2011WR-S-F-XP - **
1 2

- 1.Part No.
- 2.Finish:
(blank):Tin over Nickel
G:Gold over Nickel

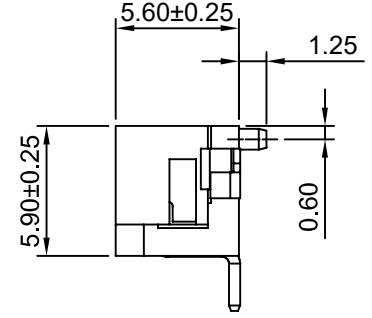
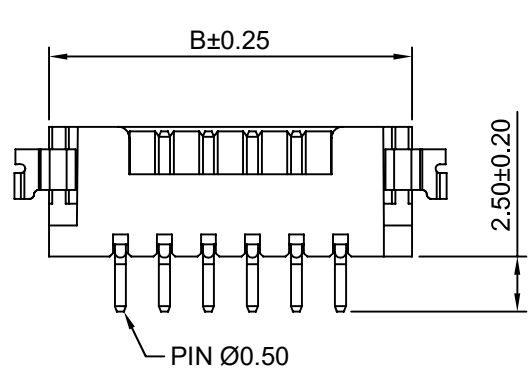
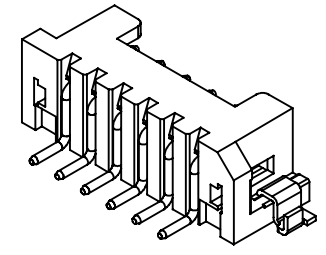
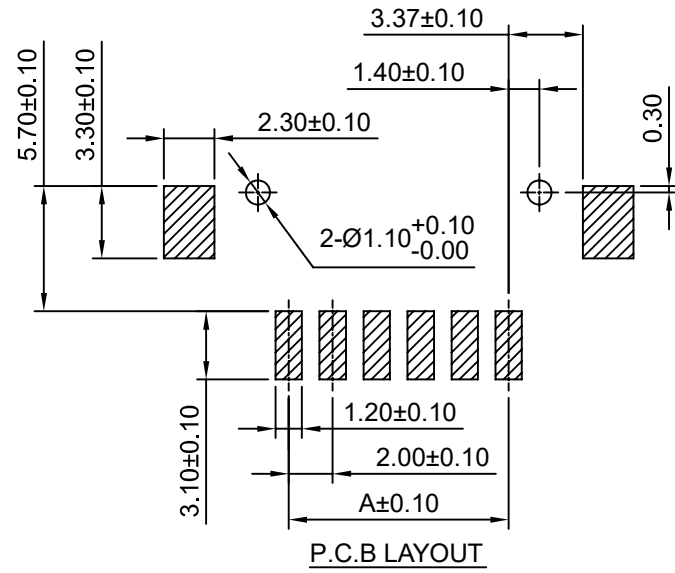
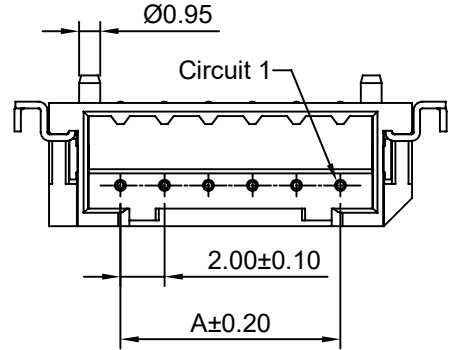

Ordering Information & Dimensions

Circuits	Dimensions(mm)		Circuits	Dimensions(mm)	
	A	B		A	B
2P	2.00	8.50	9P	16.00	22.50
3P	4.00	10.50	10P	18.00	24.50
4P	6.00	12.50	11P	20.00	26.50
5P	8.00	14.50	12P	22.00	28.50
6P	10.00	16.50	13P	24.00	30.50
7P	12.00	18.50	14P	26.00	32.50
8P	14.00	20.50	15P	28.00	34.50

SPECIFICATIONS:

- Current Rating: 3A AC,DC
- Voltage Rating: 250V AC,DC
- Temperature Range: -25°C ~ +85°C
- Contact Resistance: 30mΩ Max.
- Insulation Resistance: 1000MΩ Min.
- Withstanding Voltage: 650V AC/minute
- Pin Material: Brass/Tin over Nickel
- Solder Tabs: Brass/Tin over Nickel
- Material: Nylon 6T, UL94V-0(Ivory)

深圳市华德共创科技有限公司
Shenzhen Huade co-create Technology Co.,LTD
TEL : 0755-27129737 FAX : 0755-29940187

-TOLERANCES- UNLESS OTHERWISE SPECIFIED 公差参数表			TITLE: 产品名称: 2.00mm Pitch 90° Wafer	
X.X	±0.30	X.X°	±3°	APPD: 核准: XIE
X.XX	±0.30	X.XX°	±2°	CHECK: 校对: WANG
X.XXX	±0.10	X.XXX°	±1°	DRAW: 绘图: WANG
PART NO: 产品编号: HDGC2011WR-S-F-XP		DATE	SCALE	UNIT
		2013-08-20	3:1	mm
		CODE NUMBER		A008

修订 REV	标记 MARK	修改摘要 REVISION DESCRIPTION	签名 SIGNATURE	日期 DATE
AO		NEW RELEASE	WANG	2013-08-20

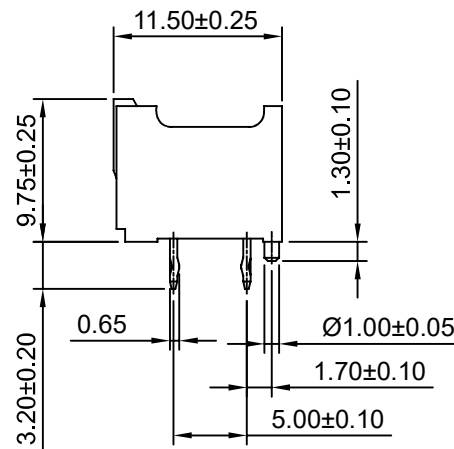
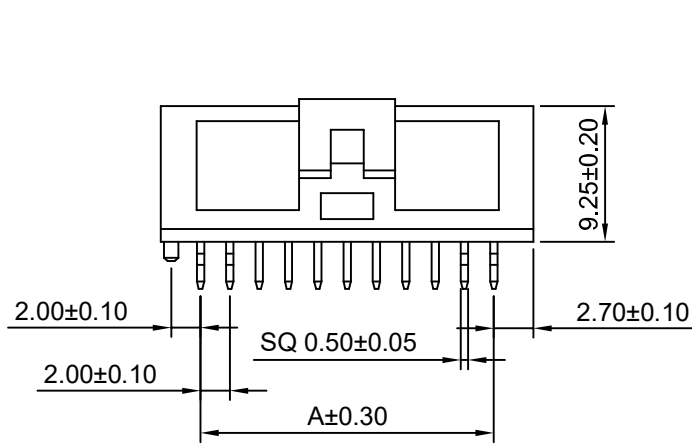
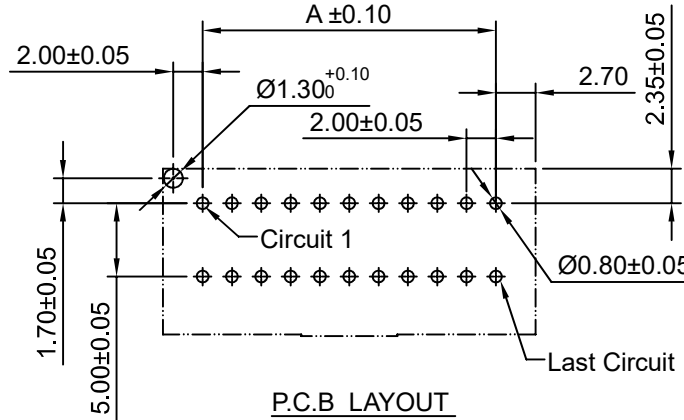
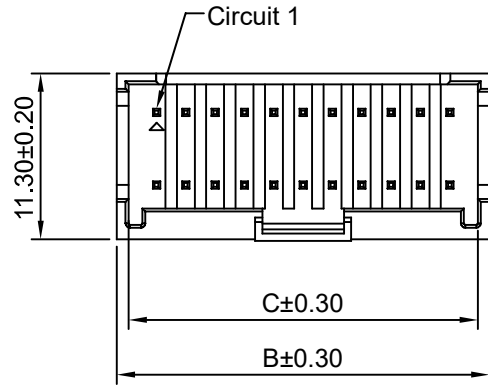

Ordering Information & Dimensions

Circuits	Dimensions(mm)			Circuits	Dimensions(mm)		
	A	B	C		A	B	C
2x4P	6.00	11.40	9.80	2x13P	24.00	29.40	27.80
2x5P	8.00	13.40	11.80	2x14P	26.00	31.40	29.80
2x6P	10.00	15.40	13.80	2x15P	28.00	33.40	31.80
2x7P	12.00	17.40	15.80	2x16P	30.00	35.40	33.80
2x8P	14.00	19.40	17.80	2x17P	32.00	37.40	35.80
2x9P	16.00	21.40	19.80	2x18P	34.00	39.40	37.80
2x10P	18.00	23.40	21.80	2x19P	36.00	41.40	39.80
2x11P	20.00	25.40	23.80	2x20P	38.00	43.40	41.80
2x12P	22.00	27.40	25.80				

SPECIFICATIONS:

Current Rating: 3A AC,DC
Voltage Rating: 250V AC,DC
Temperature Range: -25°C ~ +85°C
Contact Resistance: 20mΩ Max.
Insulation Resistance: 1000MΩ Min.
Withstanding Voltage: 1000V AC/minute
Pin Material: Brass/Tin Plated
Material: PBT UL94V-0(Black)



深圳市华德共创科技有限公司

Shenzhen Huade co-create Technology Co.,LTD
TEL : 0755-27129737 FAX : 0755-29940187

-TOLERANCES- UNLESS OTHERWISE SPECIFIED 公差参数表						TITLE: 2.00mm Pitch 产品名称: 180° Wafer			
X.X	±0.30	X.X°	±3°	APPD: 核准:	XIE	PART NO: 产品编号: HDGC2011WVA-2xXP			
X.XX	±0.30	X.XX°	±2°	CHECK: 校对:	WANG	DATE	SCALE	UNIT	CODE NUMBER
X.XXX	±0.10	X.XXX°	±1°	DRAW: 绘图:	WANG	2013-08-20	2:1	mm	A008

修订 REV	标记 MARK	修改摘要 REVISION DESCRIPTION	签名 SIGNATURE	日期 DATE
AO		NEW RELEASE	WANG	2013-08-20

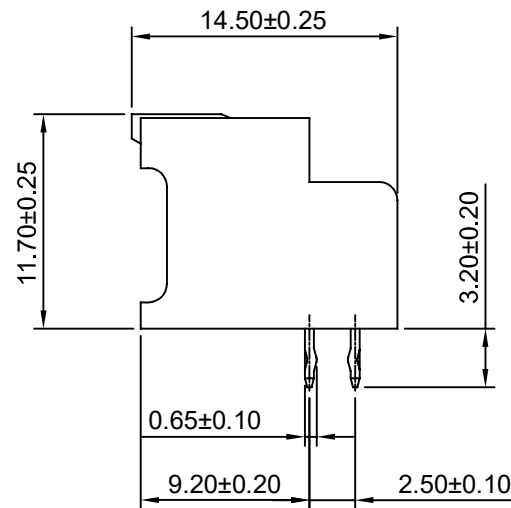
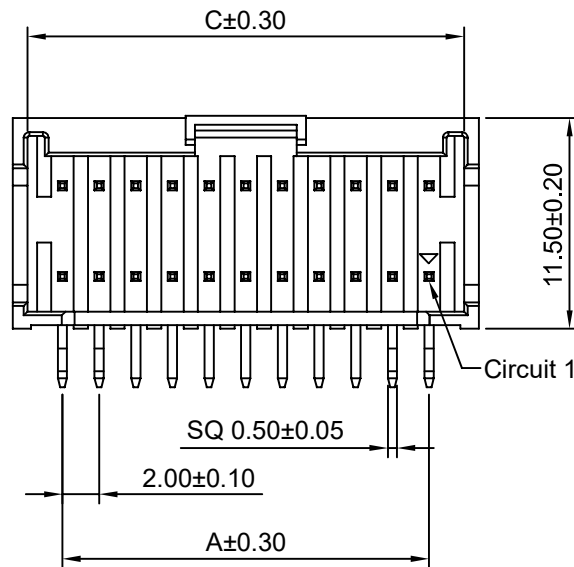
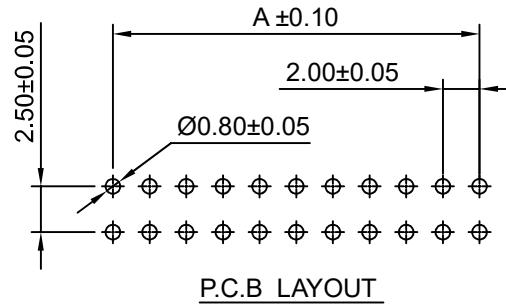
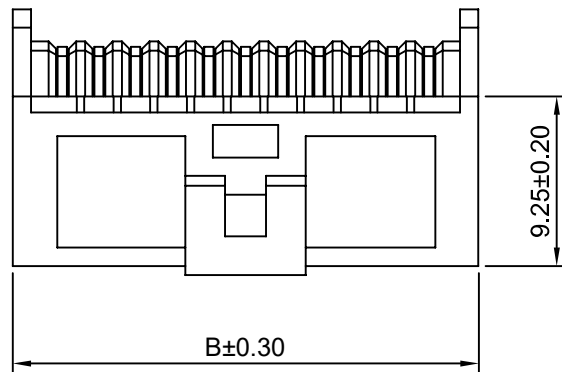

Ordering Information & Dimensions

Circuits	Dimensions(mm)			Circuits	Dimensions(mm)		
	A	B	C		A	B	C
2x4P	6.00	11.40	9.80	2x13P	24.00	29.40	27.80
2x5P	8.00	13.40	11.80	2x14P	26.00	31.40	29.80
2x6P	10.00	15.40	13.80	2x15P	28.00	33.40	31.80
2x7P	12.00	17.40	15.80	2x16P	30.00	35.40	33.80
2x8P	14.00	19.40	17.80	2x17P	32.00	37.40	35.80
2x9P	16.00	21.40	19.80	2x18P	34.00	39.40	37.80
2x10P	18.00	23.40	21.80	2x19P	36.00	41.40	39.80
2x11P	20.00	25.40	23.80	2x20P	38.00	43.40	41.80
2x12P	22.00	27.40	25.80				

SPECIFICATIONS:

Current Rating: 3A AC,DC
Voltage Rating: 250V AC,DC
Temperature Range: -25°C ~ +85°C
Contact Resistance: 20mΩ Max.
Insulation Resistance: 1000MΩ Min.
Withstanding Voltage: 1000V AC/minute
Pin Material: Brass/Tin Plated
Material: PBT UL94V-0(Black)



深圳市华德共创科技有限公司

Shenzhen Huade co-create Technology Co.,LTD
TEL : 0755-27129737 FAX : 0755-29940187

-TOLERANCES- UNLESS OTHERWISE SPECIFIED 公差参数表						TITLE: 产品名称: 2.00mm Pitch 90° Wafer			
X.X	±0.30	X.X°	±3°	APPD: 核准:	XIE	PART NO: 产品编号: HDGC2011WRA-2xXP			
X.XX	±0.30	X.XX°	±2°	CHECK: 校对:	WANG	DATE	SCALE	UNIT	CODE NUMBER
X.XXX	±0.10	X.XXX°	±1°	DRAW: 绘图:	WANG	2013-08-20	2.5:1	mm	A008