

修订 REV	标记 MARK	修改摘要 REVISION DESCRIPTION	签名 SIGNATURE	日期 DATE
AO		NEW RELEASE	WANG	2013-04-08

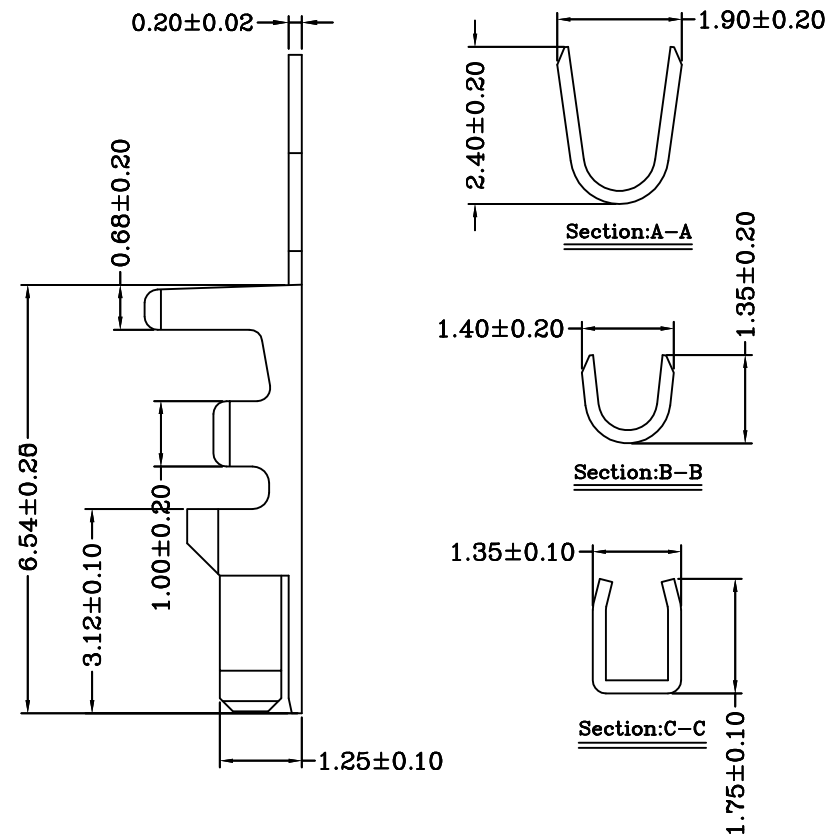
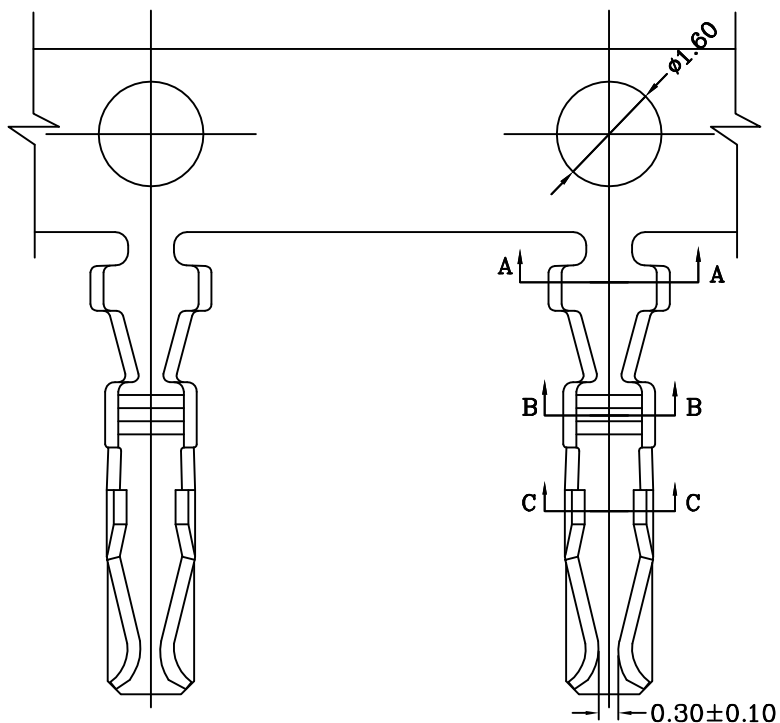

Ordering information & Specifications

Unit:mm

Part No	Wire Range	Insultion O.D.	Material	Finish	Qty/reel
HDGC2008-TP	AWG#22-#30	1.45mm(max)	Phosphor Bronze	Tin over Nickel	10,000 PCS
HDGC2008-GP	AWG#22-#30	1.45mm(max)	Phosphor Bronze	Gold over Nickel	10,000 PCS

Optional Gold plating available but MOQ requested



深圳市华德共创科技有限公司

Shenzhen Huade co-create Technology Co.,LTD

TEL : 0755-27129737 FAX : 0755-29940187

-TOLERANCES- UNLESS OTHERWISE SPECIFIED 公差参数表						TITLE: 2.00mm Pitch 产品名称: Crimp Terminal			
X.X	± 0.30	X.X°	$\pm 3^\circ$	APPD: 核准:	XIE	PART NO: 产品编号: HDGC2008-T			
X.XX	± 0.30	X.XX°	$\pm 2^\circ$	CHECK: 校对:	WANG	DATE	SCALE	UNIT	CODE NUMBER
X.XXX	± 0.10	X.XXX°	$\pm 1^\circ$	DRAW: 绘图:	WANG	2013-04-08	5:1	mm	A001

修订 REV	标记 MARK	修改摘要 REVISION DESCRIPTION	签名 SIGNATURE	日期 DATE
AO		NEW RELEASE	WANG	2013-04-08

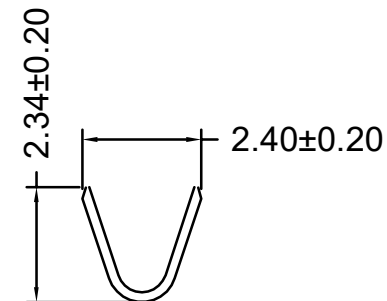
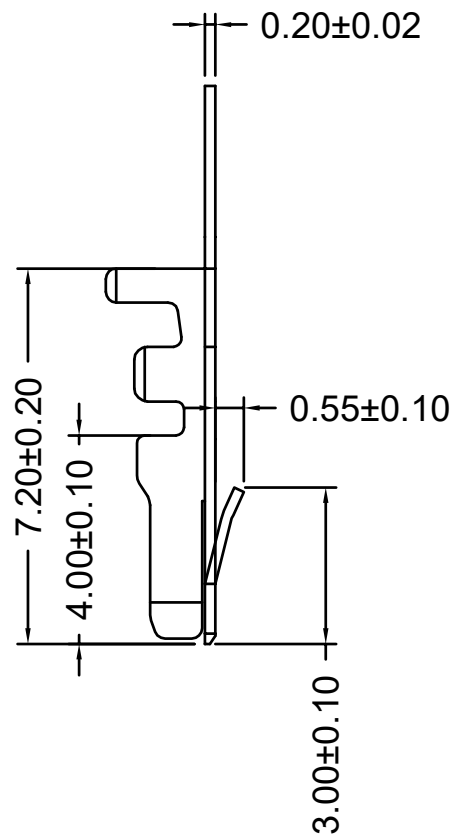
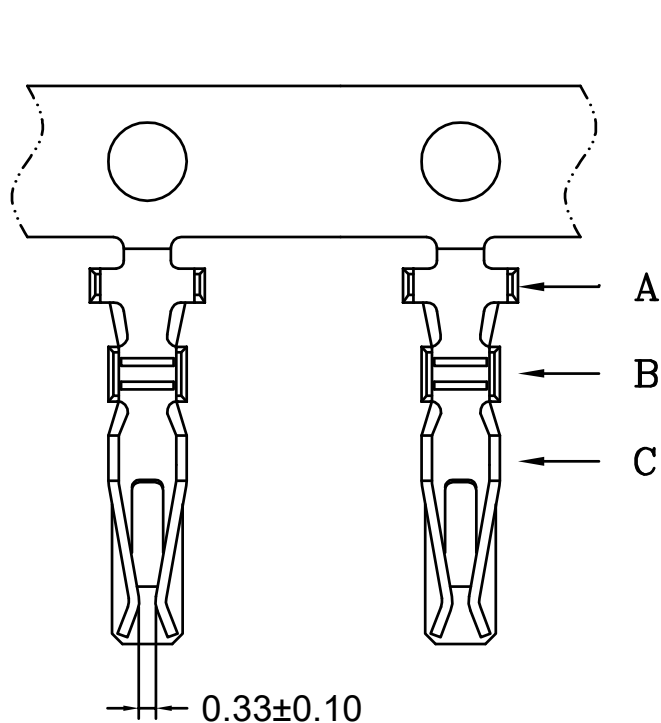

SEC:A-A

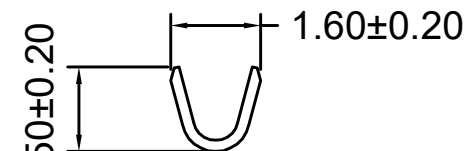

SEC:B-B

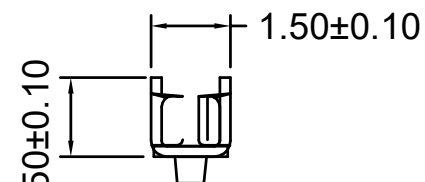

SEC:C-C

Ordering information & Specifications

Unit:mm

Part No	Wire Range	Insultion O.D.	Material	Finish	Qty/reel
HDGC2008-TP-A	AWG#22-#30	1.45mm(max)	Phosphor Bronze	Tin over Nickel	10,000 PCS
HDGC2008-GP-A	AWG#22-#30	1.45mm(max)	Phosphor Bronze	Gold over Nickel	10,000 PCS

Optional Gold plating available but MOQ requested



深圳市华德共创科技有限公司

Shenzhen Huade co-create Technology Co.,LTD

TEL : 0755-27129737 FAX : 0755-29940187

-TOLERANCES- UNLESS OTHERWISE SPECIFIED 公差参数表						TITLE: 2.00mm Pitch 产品名称: Crimp Terminal			
X.X	±0.30	X.X°	±3°	APPD: 核准:	XIE	PART NO: 产品编号: HDGC2008-T-A			
X.XX	±0.30	X.XX°	±2°	CHECK: 校对:	WANG	DATE	SCALE	UNIT	CODE NUMBER
X.XXX	±0.10	X.XXX°	±1°	DRAW: 绘图:	WANG	2013-04-08	5:1	mm	A001

修订 REV	标记 MARK	修改摘要 REVISION DESCRIPTION	签名 SIGNATURE	日期 DATE
AO		NEW RELEASE	WANG	2013-04-08

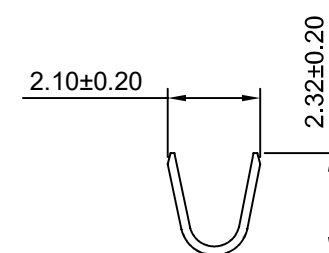
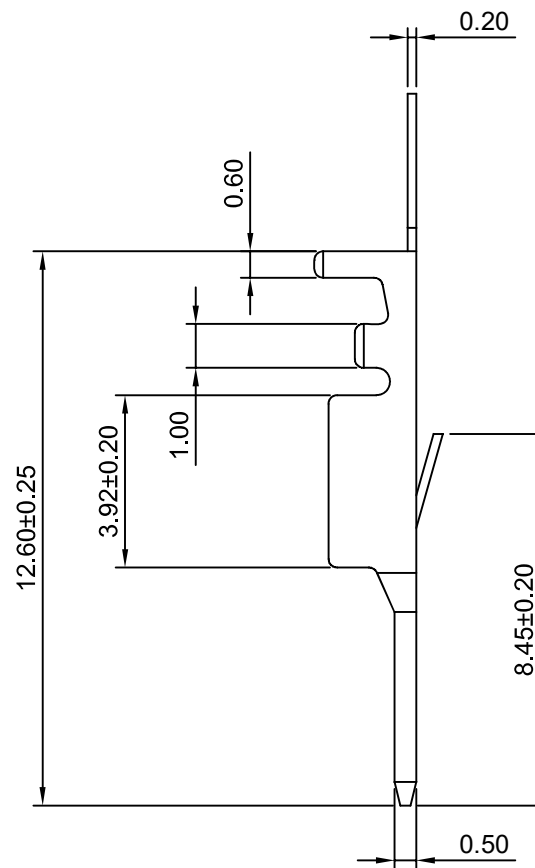
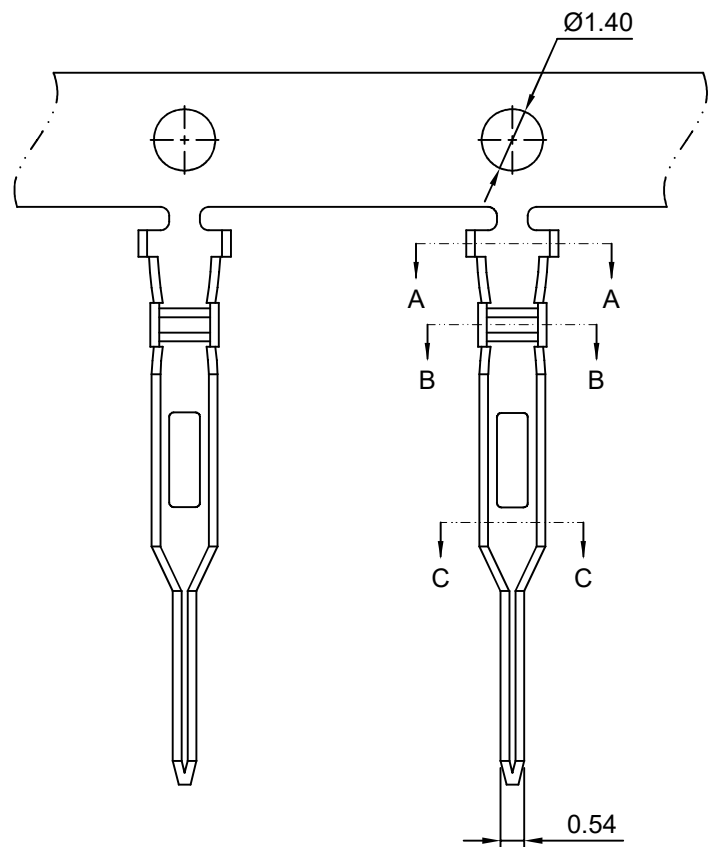

SEC:A-A

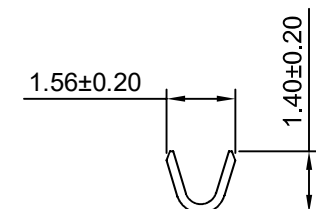

SEC:B-B

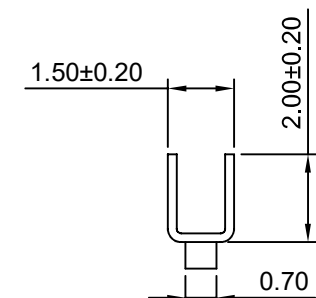

SEC:C-C

Ordering information & Specifications

Unit:mm

Part No	Wire Range	Insultion O.D.	Material	Finish	Qty/reel
HDGC2008M-TP	AWG#22-#28	1.50mm(max)	Phosphor Bronze	Tin over Nickel	15,000 PCS
HDGC2008M-GP	AWG#22-#28	1.50mm(max)	Phosphor Bronze	Gold over Nickel	15,000 PCS

Optional Gold plating available but MOQ requested



深圳市华德共创科技有限公司

Shenzhen Huade co-create Technology Co.,LTD

TEL : 0755-27129737 FAX : 0755-29940187

-TOLERANCES- UNLESS OTHERWISE SPECIFIED 公差参数表						TITLE: 产品名称: 2.00mm Pitch Crimp Terminal			
X.X	±0.30	X.X°	±3°	APPD: 核准:	XIE	PART NO: 产品编号: HDGC2008-T-B			
X.XX	±0.30	X.XX°	±2°	CHECK: 校对:	WANG	DATE	SCALE	UNIT	CODE NUMBER
X.XXX	±0.10	X.XXX°	±1°	DRAW: 绘图:	WANG	2013-04-08	6:1	mm	A008

修订 REV	标记 MARK	修改摘要 REVISION DESCRIPTION	签名 SIGNATURE	日期 DATE
AO		NEW RELEASE	WANG	2013-04-08

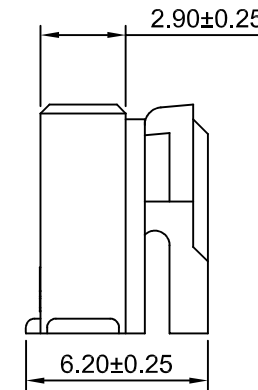
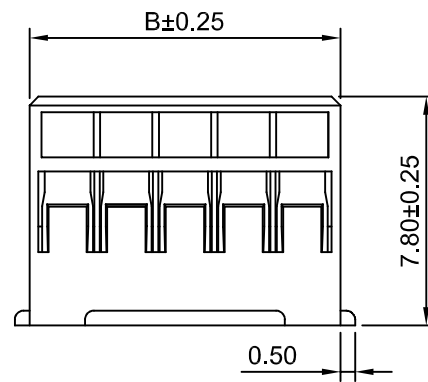
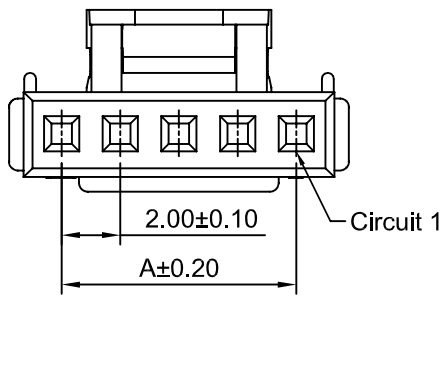
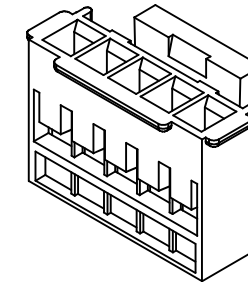
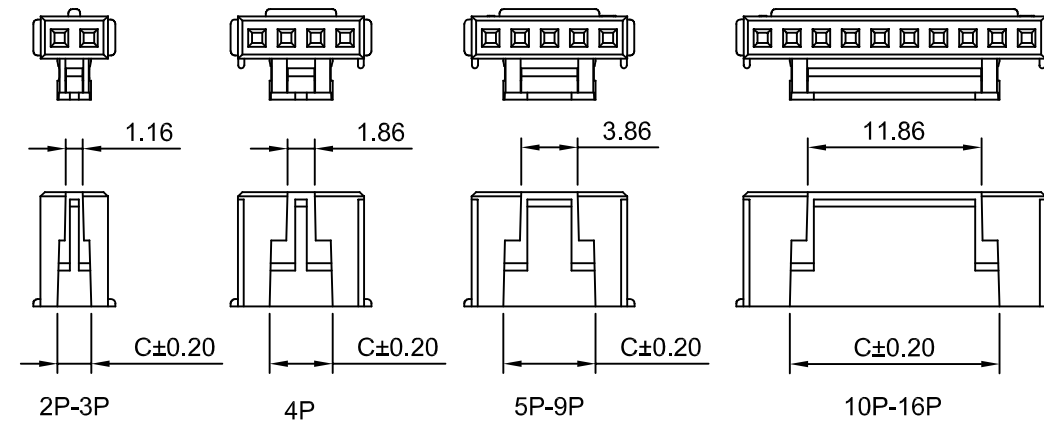

Ordering Information & Dimensions

Circuits	Dimensions(mm)			Circuits	Dimensions(mm)		
	A	B	C		A	B	C
2P	2.00	4.60	2.30	10P	18.00	20.60	14.30
3P	4.00	6.60	2.30	11P	20.00	22.60	14.30
4P	6.00	8.60	4.30	12P	22.00	24.60	14.30
5P	8.00	10.60	6.30	13P	24.00	26.60	14.30
6P	10.00	12.60	6.30	14P	26.00	28.60	14.30
7P	12.00	14.60	6.30	15P	28.00	30.60	14.30
8P	14.00	16.60	6.30	16P	30.00	32.60	14.30
9P	16.00	18.60	6.30				

SPECIFICATIONS:

Current Rating: 3A AC,DC
Voltage Rating: 250V AC,DC
Temperature Range: -25°C ~ +85°C
Contact Resistance: 30mΩ Max
Insulation Resistance: 1000MΩ Min
Withstanding Voltage: 1000V AC/minute
Material: Nylon 66,UL94V-0 (White)



深圳市华德共创科技有限公司

Shenzhen Huade co-create Technology Co.,LTD
TEL : 0755-27129737 FAX : 0755-29940187

-TOLERANCES- UNLESS OTHERWISE SPECIFIED 公差参数表						TITLE: 产品名称: 2.00mm Pitch Housing			
X.X	±0.30	X.X°	±3°	APPD: 核准:	XIE	PART NO: 产品编号: HDGC2008H-XP			
X.XX	±0.30	X.XX°	±2°	CHECK: 校对:	WANG	DATE	SCALE	UNIT	CODE NUMBER
X.XXX	±0.10	X.XXX°	±1°	DRAW: 绘图:	WANG	2013-04-08	4:1	mm	A001

修订 REV	标记 MARK	修改摘要 REVISION DESCRIPTION	签名 SIGNATURE	日期 DATE
AO		NEW RELEASE	WANG	2014-06-18

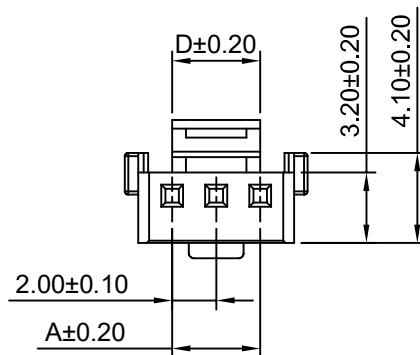
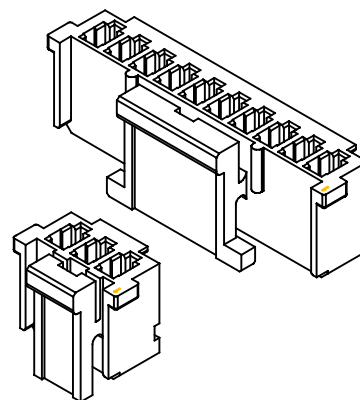
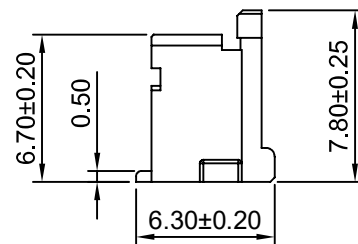
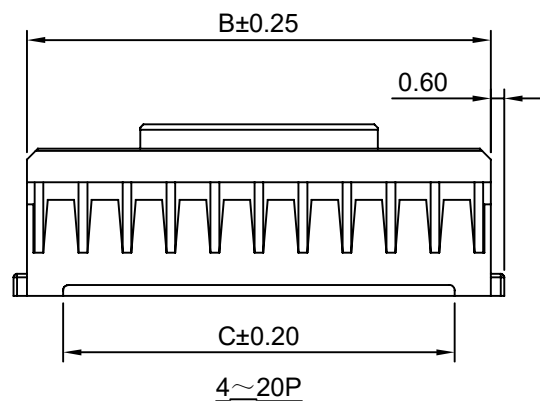
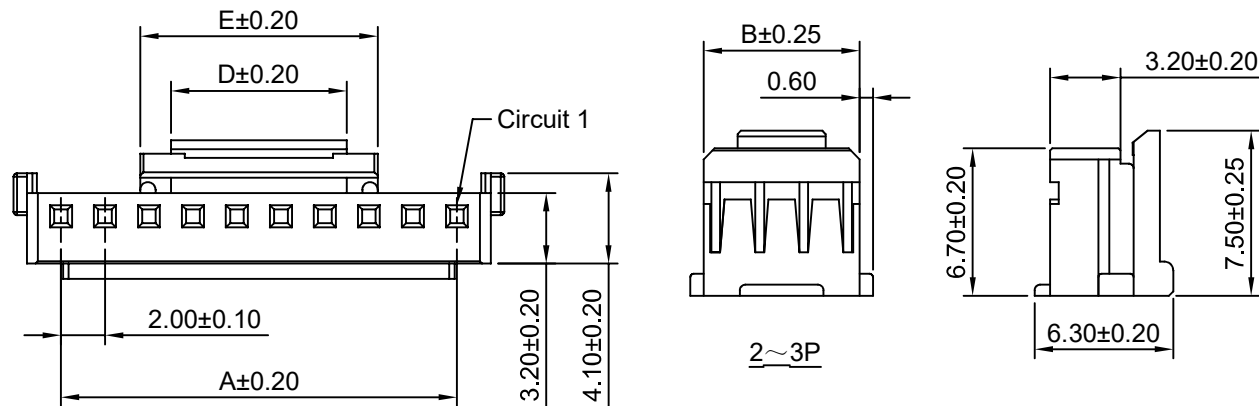

Ordering Information & Dimensions

Circuits	Dimensions(mm)				
	A	B	C	D	E
2P	2.00	5.10	1.80	4.00	---
3P	4.00	7.10	3.80	4.00	---
4P	6.00	9.10	5.80	4.00	6.40
5P	8.00	11.10	7.80	4.00	6.40
6P	10.00	13.10	9.80	4.00	6.40
7P	12.00	15.10	11.80	4.00	6.40
8P	14.00	17.10	13.80	8.00	10.80
9P	16.00	19.10	15.80	8.00	10.80
10P	18.00	21.10	17.80	8.00	10.80
11P	20.00	23.10	19.80	8.00	10.80
12P	22.00	25.10	21.80	8.00	10.80
13P	24.00	27.10	23.80	8.00	10.80
14P	26.00	29.10	25.80	8.00	10.80
15P	28.00	31.10	27.80	8.00	10.80
16P	30.00	33.10	29.80	8.00	10.80
17P	32.00	35.10	31.80	8.00	10.80
18P	34.00	37.10	33.80	8.00	10.80
19P	36.00	39.10	35.80	8.00	10.80
20P	38.00	41.10	37.80	8.00	10.80

SPECIFICATIONS:

Current Rating: 3A AC,DC
Voltage Rating: 250V AC,DC
Temperature Range: -25°C ~ +85°C
Contact Resistance: 30mΩ Max
Insulation Resistance: 1000MΩ Min
Withstanding Voltage: 1000V AC/minute
Material: Nylon 66,UL94V-0(Ivory)



深圳市华德共创科技有限公司

Shenzhen Huade co-create Technology Co.,LTD

TEL : 0755-27129737 FAX : 0755-29940187

-TOLERANCES- UNLESS OTHERWISE SPECIFIED 公差参数表				TITLE: 产品名称: 2.00mm Pitch Housing	
X.X	±0.30	X.X°	±3°	APPD: 核准:	XIE
X.XX	±0.30	X.XX°	±2°	CHECK: 校对:	WANG
X.XXX	±0.10	X.XXX°	±1°	DRAW: 绘图:	WANG
PART NO: 产品编号:		HDGC2008HA-XP			
DATE		SCALE	UNIT	CODE NUMBER	
2014-06-18		3:1	mm	A008	

修订 REV	标记 MARK	修改摘要 REVISION DESCRIPTION	签名 SIGNATURE	日期 DATE
AO		NEW RELEASE	WANG	2014-06-18

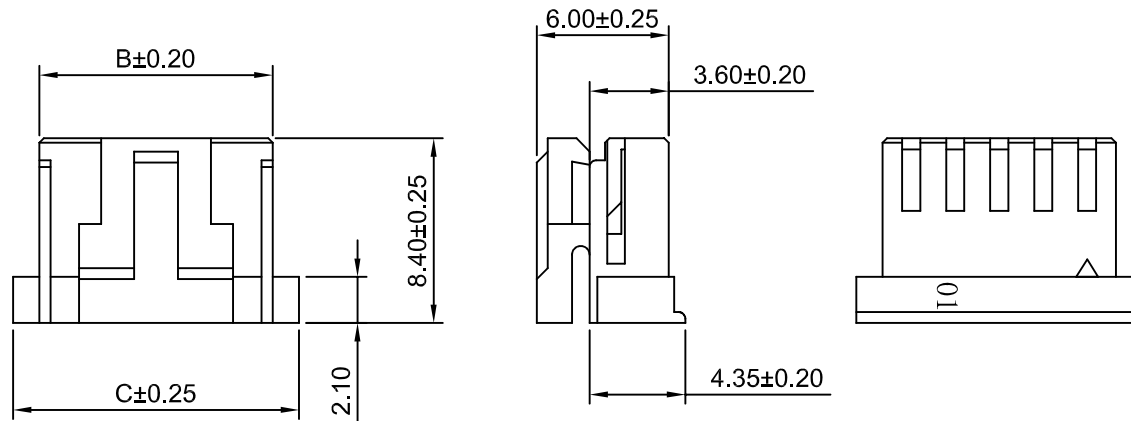
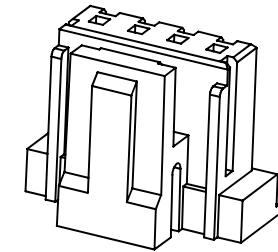
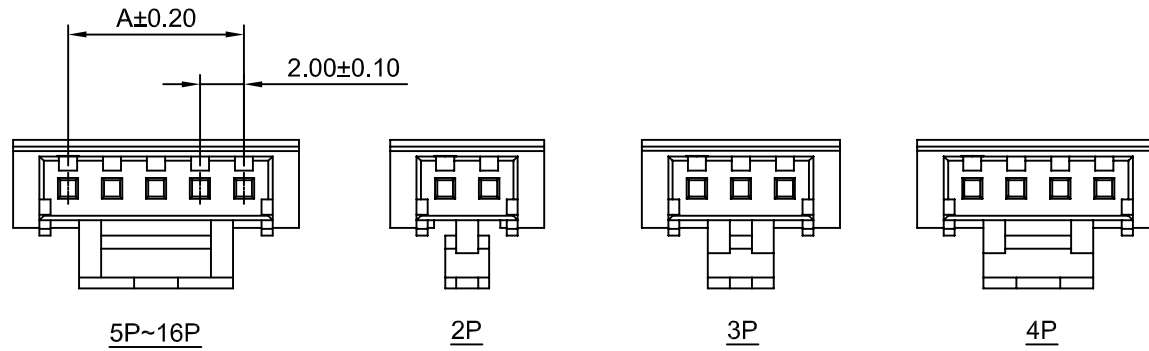

Ordering Information & Dimensions



Circuits	Dimensions(mm)			Circuits	Dimensions(mm)		
	A	B	C		A	B	C
2P	2.00	4.60	7.00	10P	18.00	20.60	23.00
3P	4.00	6.60	9.00	11P	20.00	22.60	25.00
4P	6.00	8.60	11.00	12P	22.00	24.60	27.00
5P	8.00	10.60	13.00	13P	24.00	26.60	29.00
6P	10.00	12.60	15.00	14P	26.00	28.60	31.00
7P	12.00	14.60	17.00	15P	28.00	30.60	33.00
8P	14.00	16.60	19.00	16P	30.00	32.60	35.00
9P	16.00	18.60	21.00				

SPECIFICATIONS:

Current Rating: 3A AC,DC
Voltage Rating: 250V AC,DC
Temperature Range: -25°C ~ +85°C
Contact Resistance: 30mΩ Max.
Insulation Resistance: 1000MΩ Min.
Withstanding Voltage: 1000V AC/minute
Material: Nylon 66, UL94V-0(White)



深圳市华德共创科技有限公司
Shenzhen Huade co-create Technology Co.,LTD
TEL : 0755-27129737 FAX : 0755-29940187

-TOLERANCES- UNLESS OTHERWISE SPECIFIED 公差参数表				 		TITLE: 产品名称: 2.00mm Pitch Housing			
X.X	±0.30	X.X°	±3°	APPD: 核准:	XIE	PART NO: 产品编号: HDGC2008HB-XP			
X.XX	±0.30	X.XX°	±2°	CHECK: 校对:	WANG	DATE	SCALE	UNIT	CODE NUMBER
X.XXX	±0.10	X.XXX°	±1°	DRAW: 绘图:	WANG	2014-06-18	3:1	mm	A008

修订 REV	标记 MARK	修改摘要 REVISION DESCRIPTION	签名 SIGNATURE	日期 DATE
AO		NEW RELEASE	WANG	2014-06-18

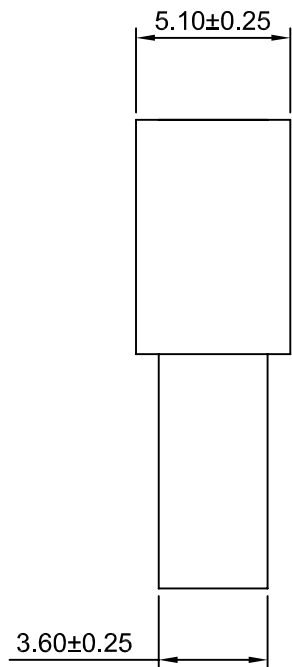
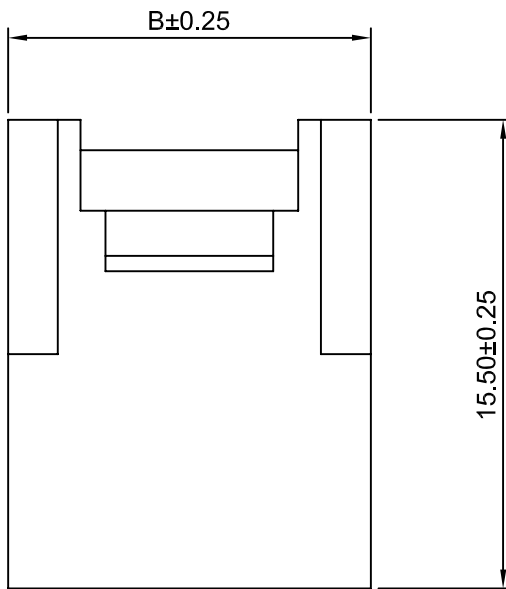
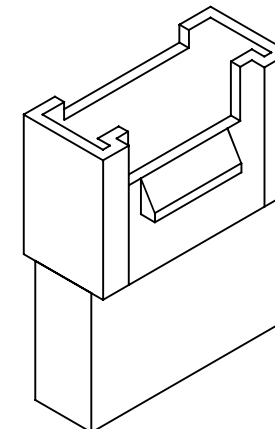
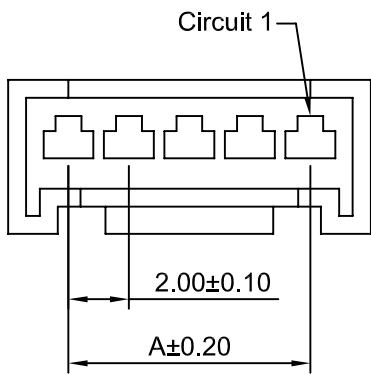

Ordering Information & Dimensions

Circuits	Dimensions(mm)		Circuits	Dimensions(mm)	
	A	B		A	B
2P	2.00	6.00	9P	16.00	20.00
3P	4.00	8.00	10P	18.00	22.00
4P	6.00	10.00	11P	20.00	24.00
5P	8.00	12.00	12P	22.00	26.00
6P	10.00	14.00	13P	24.00	28.00
7P	12.00	16.00	14P	26.00	30.00
8P	14.00	18.00	15P	28.00	32.00

SPECIFICATIONS:
 Current Rating: 3A AC,DC
 Voltage Rating: 250V AC,DC
 Temperature Range: -25°C ~ +85°C
 Contact Resistance: 30mΩ Max
 Insulation Resistance: 1000MΩ Min
 Withstanding Voltage: 1000V AC/minute
 Material: Nylon 66,UL94V-0(White)



深圳市华德共创科技有限公司

Shenzhen Huade co-create Technology Co.,LTD
 TEL : 0755-27129737 FAX : 0755-29940187

-TOLERANCES- UNLESS OTHERWISE SPECIFIED 公差参数表						TITLE: 产品名称: 2.00mm Pitch Housing			
X.X	±0.30	X.X°	±3°	APPD: 核准:	XIE	PART NO: 产品编号: HDGC2008HM-XP			
X.XX	±0.30	X.XX°	±2°	CHECK: 校对:	WANG	DATE	SCALE	UNIT	CODE NUMBER
X.XXX	±0.10	X.XXX°	±1°	DRAW: 绘图:	WANG	2014-06-18	4:1	mm	A008

修订 REV	标记 MARK	修改摘要 REVISION DESCRIPTION	签名 SIGNATURE	日期 DATE
AO		NEW RELEASE	WANG	2014-06-18

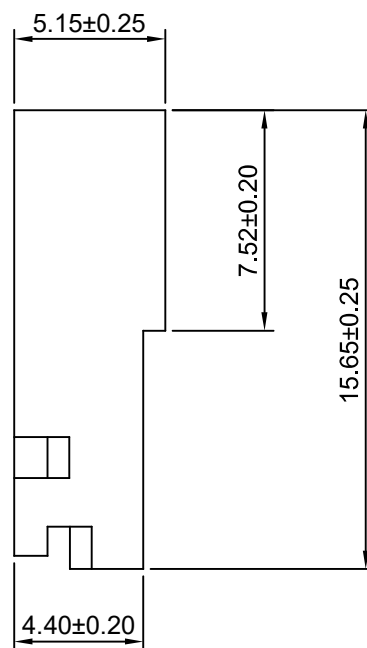
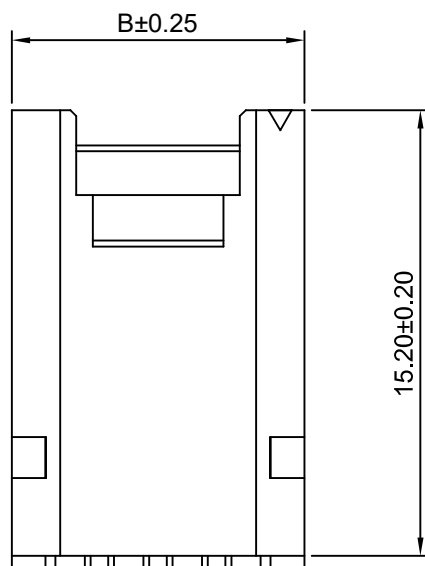
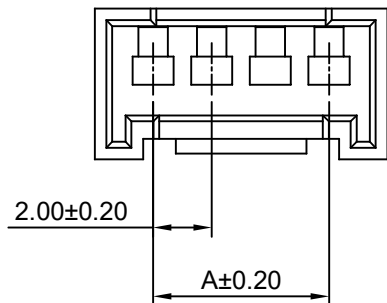

Ordering Information & Dimensions

Circuits	Dimensions(mm)		Circuits	Dimensions(mm)	
	A	B		A	B
2P	2.00	5.98	9P	16.00	19.98
3P	4.00	7.98	10P	18.00	21.98
4P	6.00	9.98	11P	20.00	23.98
5P	8.00	11.98	12P	22.00	25.98
6P	10.00	13.98	13P	24.00	27.98
7P	12.00	15.98	14P	26.00	29.98
8P	14.00	17.98	15P	28.00	31.98

SPECIFICATIONS:

Current Rating: 3A AC,DC
Voltage Rating: 250V AC,DC
Temperature Range: -25°C ~ +85°C
Contact Resistance: 20mΩ Max.
Insulation Resistance: 1000MΩ Min.
Withstanding Voltage: 1000V AC/minute
Material: Nylon66 UL94V-0(White)



深圳市华德共创科技有限公司

Shenzhen Huade co-create Technology Co.,LTD
TEL : 0755-27129737 FAX : 0755-29940187

-TOLERANCES- UNLESS OTHERWISE SPECIFIED 公差参数表						TITLE: 产品名称: 2.00mm Pitch Housing			
X.X	±0.30	X.X°	±3°	APPD: 核准:	XIE	PART NO: 产品编号: HDGC2008HMB-XP			
X.XX	±0.30	X.XX°	±2°	CHECK: 校对:	WANG	DATE	SCALE	UNIT	CODE NUMBER
X.XXX	±0.10	X.XXX°	±1°	DRAW: 绘图:	WANG	2014-06-18	4:1	mm	A008

修订 REV	标记 MARK	修改摘要 REVISION DESCRIPTION	签名 SIGNATURE	日期 DATE
AO		NEW RELEASE	WANG	2014-06-18

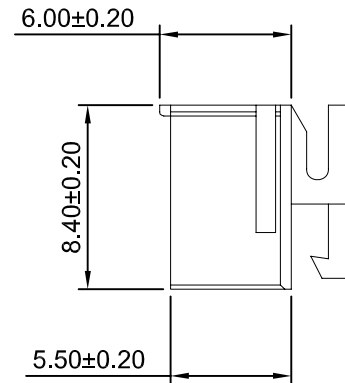
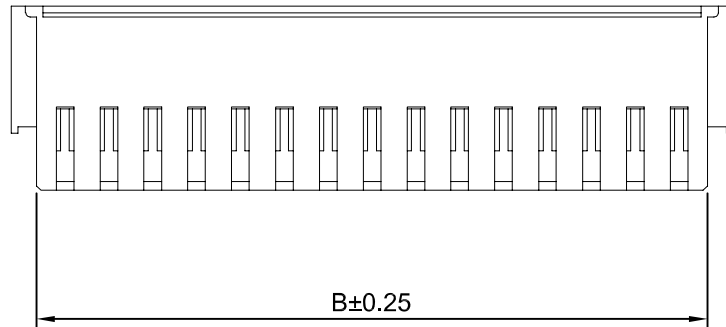
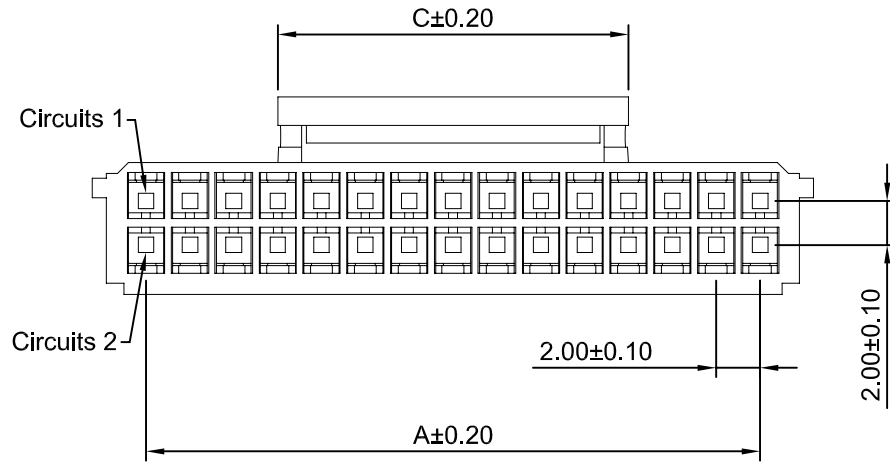

Ordering Information & Dimensions

Circuits	Dimensions(mm)			Circuits	Dimensions(mm)		
	A	B	C		A	B	C
2x3P	4.00	6.60	5.00	2x12P	22.00	24.60	11.00
2x4P	6.00	8.60	5.00	2x13P	24.00	26.60	11.00
2x5P	8.00	10.60	5.50	2x14P	26.00	28.60	16.00
2x6P	10.00	12.60	5.50	2x15P	28.00	30.60	16.00
2x7P	12.00	14.60	5.50	2x16P	30.00	32.60	16.00
2x8P	14.00	16.60	11.00	2x17P	32.00	34.60	16.00
2x9P	16.00	18.60	11.00	2x18P	34.00	36.60	16.00
2x10P	18.00	20.60	11.00	2x19P	36.00	38.60	16.00
2x11P	20.00	22.60	11.00	2x20P	38.00	40.60	16.00

SPECIFICATIONS:
 Current Rating: 3A AC,DC
 Voltage Rating: 250V AC,DC
 Temperature Range: -25°C ~ +85°C
 Contact Resistance: 30mΩ Max
 Insulation Resistance: 1000MΩ Min
 Withstanding Voltage: 1000V AC/minute
 Material: Nylon 66,UL94V-0 (White)

HDGC 深圳市华德共创科技有限公司
 Shenzhen Huade co-create Technology Co.,LTD
 TEL : 0755-27129737 FAX : 0755-29940187

-TOLERANCES- UNLESS OTHERWISE SPECIFIED 公差参数表						TITLE: 产品名称: 2.00mm Pitch Housing			
X.X	±0.30	X.X°	±3°	APPD: 核准:	XIE	PART NO: 产品编号: HDGC2008H-2xXP			
X.XX	±0.30	X.XX°	±2°	CHECK: 校对:	WANG	DATE	SCALE	UNIT	CODE NUMBER
X.XXX	±0.10	X.XXX°	±1°	DRAW: 绘图:	WANG	2014-06-18	3:1	mm	A008

修订 REV	标记 MARK	修改摘要 REVISION DESCRIPTION	签名 SIGNATURE	日期 DATE
AO		NEW RELEASE	WANG	2014-06-18

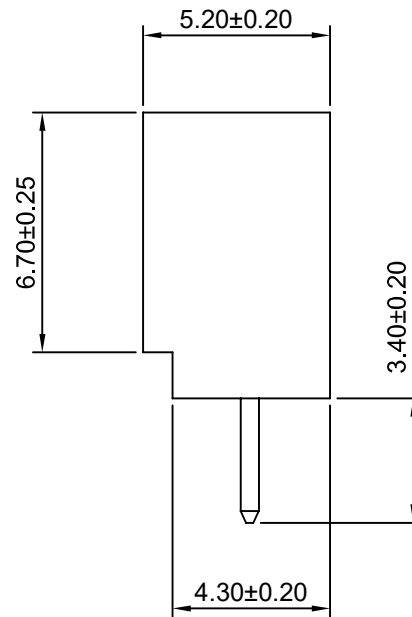
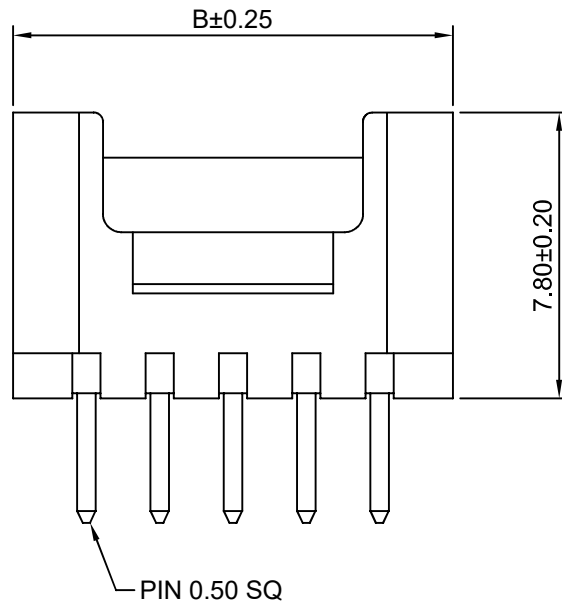
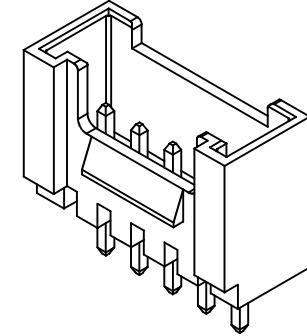
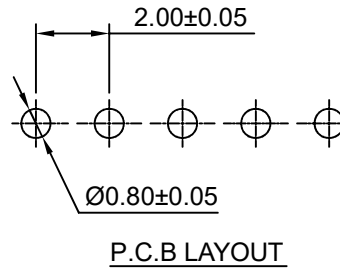
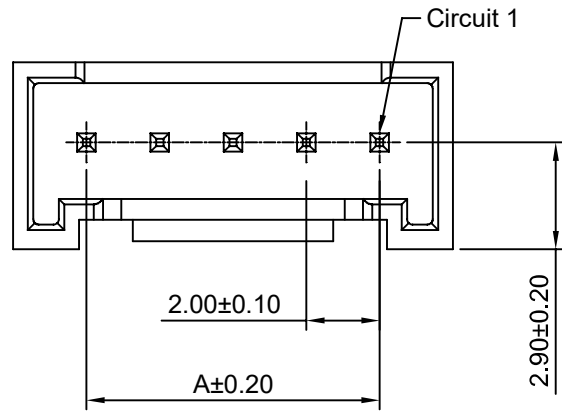

Ordering Information & Dimensions

Circuits	Dimensions(mm)		Circuits	Dimensions(mm)	
	A	B		A	B
2P	2.00	6.00	10P	18.00	22.00
3P	4.00	8.00	11P	20.00	24.00
4P	6.00	10.00	12P	22.00	26.00
5P	8.00	12.00	13P	24.00	28.00
6P	10.00	14.00	14P	26.00	30.00
7P	12.00	16.00	15P	28.00	32.00
8P	14.00	18.00	16P	30.00	34.00
9P	16.00	20.00			

SPECIFICATIONS:

Current Rating: 3A AC,DC
Voltage Rating: 250V AC,DC
Temperature Range: -25°C ~ +85°C
Contact Resistance: 30mΩ Max
Insulation Resistance: 1000MΩ Min
Withstanding Voltage: 1000V AC/minute
Pin Material: Brass/Tin over Nickel
Material: Nylon 66,UL94V-0 (White)



深圳市华德共创科技有限公司

Shenzhen Huade co-create Technology Co.,LTD
TEL : 0755-27129737 FAX : 0755-29940187

-TOLERANCES- UNLESS OTHERWISE SPECIFIED 公差参数表				 		TITLE: 产品名称: 2.00mm Pitch 180° Wafer			
X.X	±0.30	X.X°	±3°	APPD: 核准:	XIE	PART NO: 产品编号: HDGC2008WV-XP			
X.XX	±0.30	X.XX°	±2°	CHECK: 校对:	WANG	DATE	SCALE	UNIT	CODE NUMBER
X.XXX	±0.10	X.XXX°	±1°	DRAW: 绘图:	WANG	2014-06-18	5:1	mm	A008

修订 REV	标记 MARK	修改摘要 REVISION DESCRIPTION	签名 SIGNATURE	日期 DATE
AO		NEW RELEASE	WANG	2014-06-18

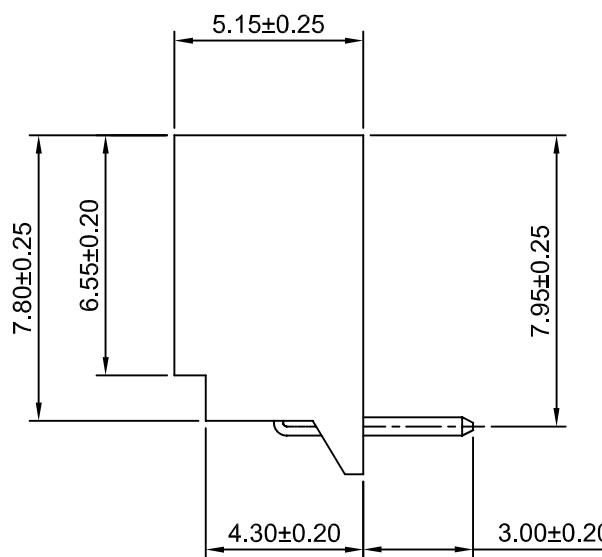
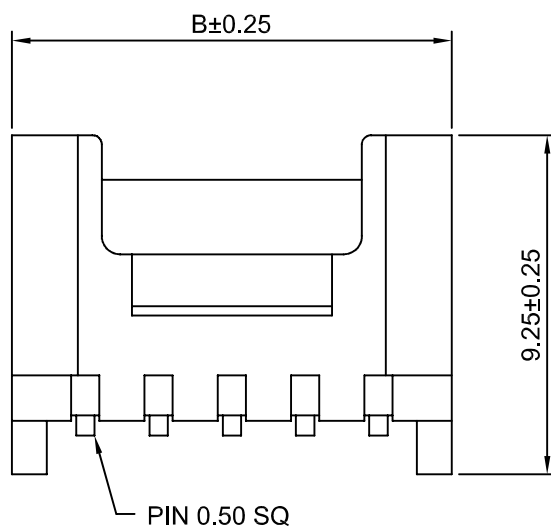
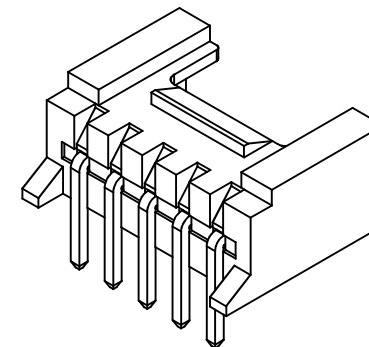
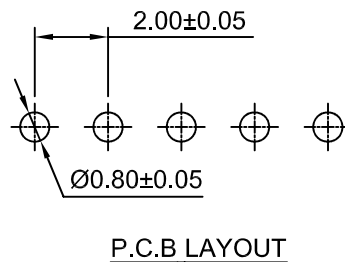
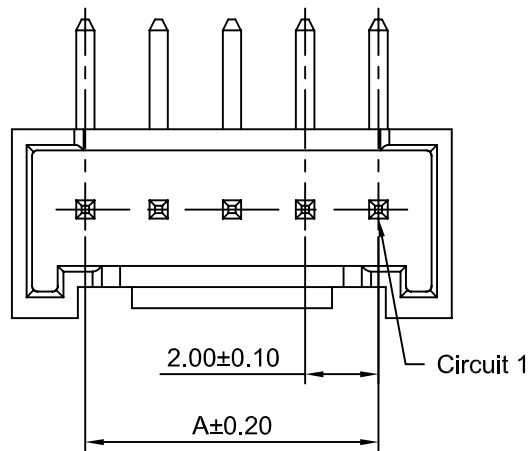

Ordering Information & Dimensions

Circuits	Dimensions(mm)		Circuits	Dimensions(mm)	
	A	B		A	B
2P	2.00	6.00	10P	18.00	22.00
3P	4.00	8.00	11P	20.00	24.00
4P	6.00	10.00	12P	22.00	26.00
5P	8.00	12.00	13P	24.00	28.00
6P	10.00	14.00	14P	26.00	30.00
7P	12.00	16.00	15P	28.00	32.00
8P	14.00	18.00	16P	30.00	34.00
9P	16.00	20.00			

SPECIFICATIONS:

Current Rating: 3A AC,DC
Voltage Rating: 250V AC,DC
Temperature Range: -25°C ~ +85°C
Contact Resistance: 30mΩ Max
Insulation Resistance: 1000MΩ Min
Withstanding Voltage: 1000V AC/minute
Pin Material: Brass/Tin over Nickel
Material: Nylon 66,UL94V-0 (White)



深圳市华德共创科技有限公司

Shenzhen Huade co-create Technology Co.,LTD

TEL : 0755-27129737 FAX : 0755-29940187

-TOLERANCES- UNLESS OTHERWISE SPECIFIED 公差参数表				TITLE: 产品名称: 2.00mm Pitch 90° Wafer	
X.X	±0.30	X.X°	±3°	APPD: 核准:	XIE
X.XX	±0.30	X.XX°	±2°	CHECK: 校对:	WANG
X.XXX	±0.10	X.XXX°	±1°	DRAW: 绘图:	WANG
PART NO: 产品编号:		HDGC2008WR-XP			
DATE	SCALE	UNIT	CODE NUMBER		
2014-06-18	5:1	mm	A008		

修订 REV	标记 MARK	修改摘要 REVISION DESCRIPTION	签名 SIGNATURE	日期 DATE
AO		NEW RELEASE	WANG	2014-06-18

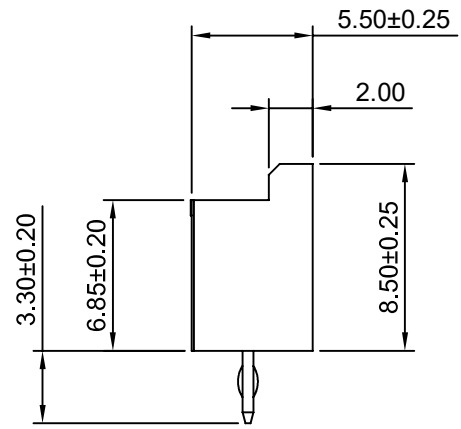
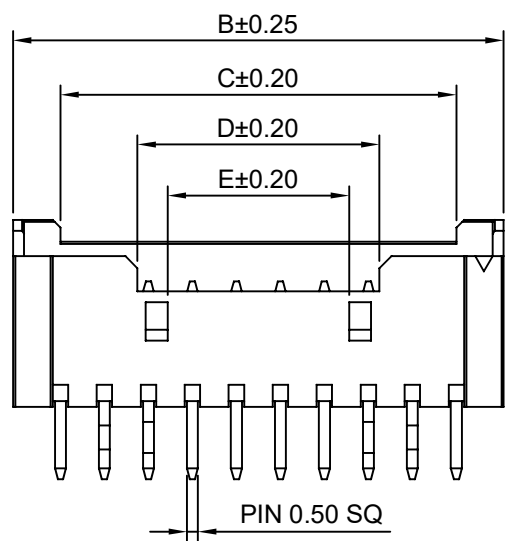
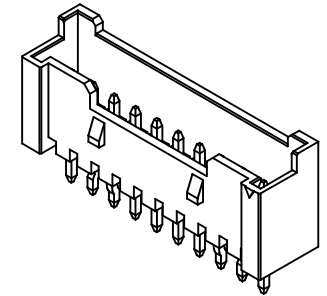
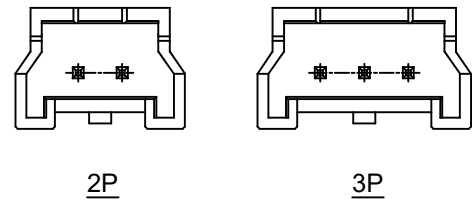
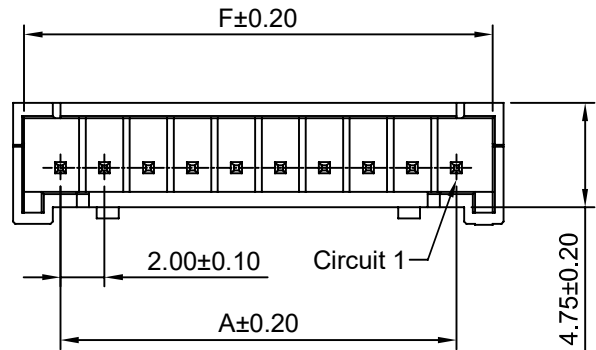

Ordering Information & Dimensions

Circuits	Dimensions(mm)					
	A	B	C	D	E	F
2P	2.00	7.70	2.00	4.10	----	5.30
3P	4.00	9.70	4.00	6.10	----	7.30
4P	6.00	10.30	6.00	7.00	4.25	9.30
5P	8.00	12.30	8.00	7.00	4.25	11.30
6P	10.00	14.30	10.00	7.00	4.25	13.30
7P	12.00	16.30	12.00	7.00	4.25	15.30
8P	14.00	18.30	14.00	11.00	8.25	17.30
9P	16.00	20.30	16.00	11.00	8.25	19.30
10P	18.00	22.30	18.00	11.00	8.25	21.30
11P	20.00	24.30	20.00	11.00	8.25	23.30
12P	22.00	26.30	22.00	11.00	8.25	25.30
13P	24.00	28.30	24.00	11.00	8.25	27.30
14P	26.00	30.30	26.00	11.00	8.25	29.30
15P	28.00	32.30	28.00	11.00	8.25	31.30
16P	30.00	34.30	30.00	11.00	8.25	33.30
17P	32.00	36.30	32.00	11.00	8.25	35.30
18P	34.00	38.30	34.00	11.00	8.25	37.30
19P	36.00	40.30	36.00	11.00	8.25	39.30
20P	38.00	42.30	38.00	11.00	8.25	41.30

SPECIFICATIONS:
 Current Rating: 3A AC,DC
 Voltage Rating: 250V AC,DC
 Temperature Range: -25°C ~ +85°C
 Contact Resistance: 30mΩ Max
 Insulation Resistance: 1000MΩ Min
 Withstanding Voltage: 1000V AC/minute
 Pin Material: Brass/Tin over Nickel
 Material: Nylon 66,UL94V-0(Ivory)

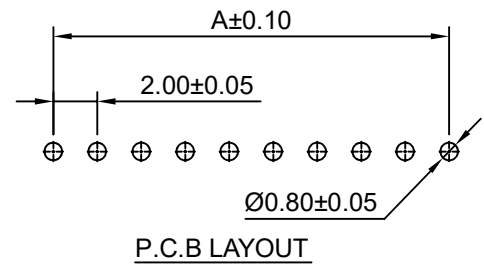

深圳市华德共创科技有限公司
 Shenzhen Huade co-create Technology Co.,LTD
 TEL : 0755-27129737 FAX : 0755-29940187

-TOLERANCES- UNLESS OTHERWISE SPECIFIED 公差参数表			 TITLE: 2.00mm Pitch 产品名称: 180° Wafer
X.X ±0.30	X.X° ±3°	APPD: 核准: XIE	PART NO: HDGC2008WA-XP 产品编号:
X.XX ±0.30	X.XX° ±2°	CHECK: 校对: WANG	DATE SCALE UNIT CODE NUMBER
X.XXX ±0.10	X.XXX° ±1°	DRAW: 绘图: WANG	2014-06-18 3:1 mm A008

修订 REV	标记 MARK	修改摘要 REVISION DESCRIPTION	签名 SIGNATURE	日期 DATE
AO		NEW RELEASE	WANG	2014-06-18

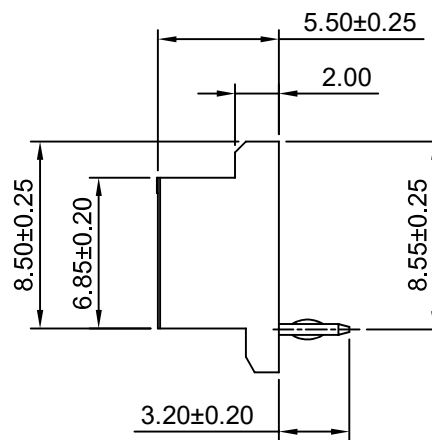
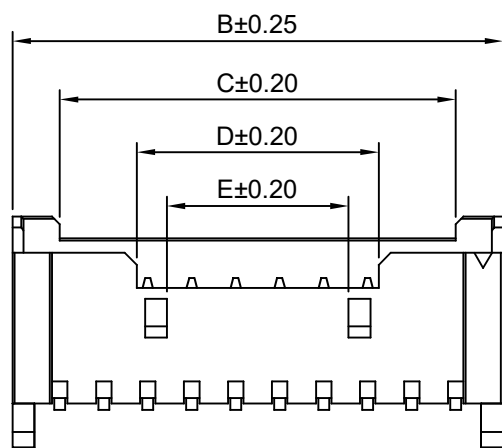
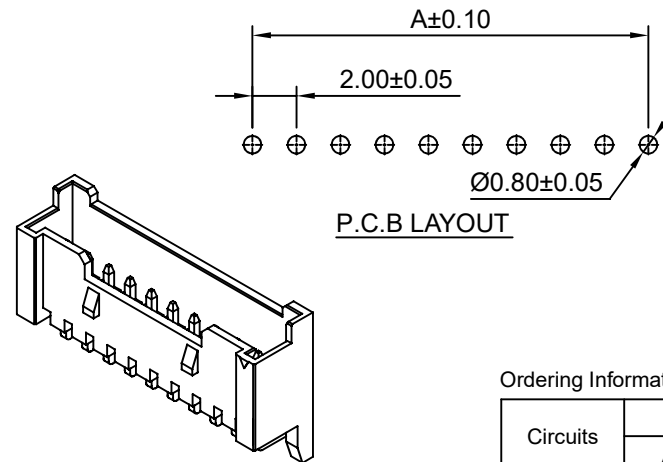
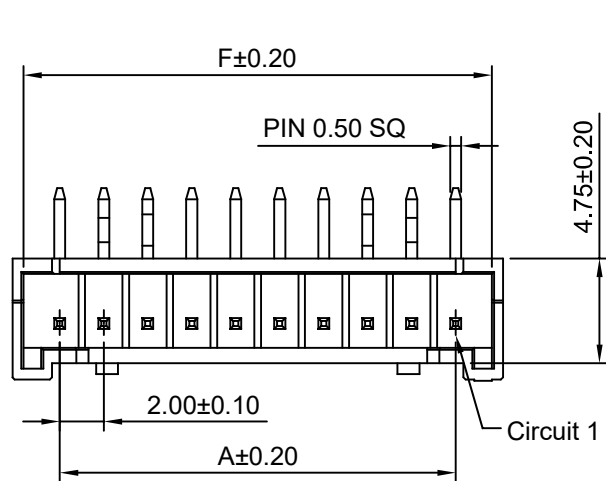

Ordering Information & Dimensions

Circuits	Dimensions(mm)					
	A	B	C	D	E	F
4P	6.00	10.30	6.00	7.00	4.25	9.30
5P	8.00	12.30	8.00	7.00	4.25	11.30
6P	10.00	14.30	10.00	7.00	4.25	13.30
7P	12.00	16.30	12.00	7.00	4.25	15.30
8P	14.00	18.30	14.00	11.00	8.25	17.30
9P	16.00	20.30	16.00	11.00	8.25	19.30
10P	18.00	22.30	18.00	11.00	8.25	21.30
11P	20.00	24.30	20.00	11.00	8.25	23.30
12P	22.00	26.30	22.00	11.00	8.25	25.30
13P	24.00	28.30	24.00	11.00	8.25	27.30
14P	26.00	30.30	26.00	11.00	8.25	29.30
15P	28.00	32.30	28.00	11.00	8.25	31.30
16P	30.00	34.30	30.00	11.00	8.25	33.30
17P	32.00	36.30	32.00	11.00	8.25	35.30
18P	34.00	38.30	34.00	11.00	8.25	37.30
19P	36.00	40.30	36.00	11.00	8.25	39.30
20P	38.00	42.30	38.00	11.00	8.25	41.30

SPECIFICATIONS:

Current Rating: 3A AC,DC
Voltage Rating: 250V AC,DC
Temperature Range: -25°C ~ +85°C
Contact Resistance: 30mΩ Max
Insulation Resistance: 1000MΩ Min
Withstanding Voltage: 1000V AC/minute
Pin Material: Brass/Tin over Nickel
Material: Nylon 66,UL94V-0(Ivory)



深圳市华德共创科技有限公司

Shenzhen Huade co-create Technology Co.,LTD

TEL : 0755-27129737 FAX : 0755-29940187

-TOLERANCES- UNLESS OTHERWISE SPECIFIED 公差参数表						TITLE: 产品名称: 2.00mm Pitch 90° Wafer			
X.X	±0.30	X.X°	±3°	APPD: 核准:	XIE	PART NO: 产品编号: HDGC2008WRA-XP			
X.XX	±0.30	X.XX°	±2°	CHECK: 校对:	WANG	DATE	SCALE	UNIT	CODE NUMBER
X.XXX	±0.10	X.XXX°	±1°	DRAW: 绘图:	WANG	2014-06-18	3:1	mm	A008

修订 REV	标记 MARK	修改摘要 REVISION DESCRIPTION	签名 SIGNATURE	日期 DATE
AO		NEW RELEASE	WANG	2014-06-18

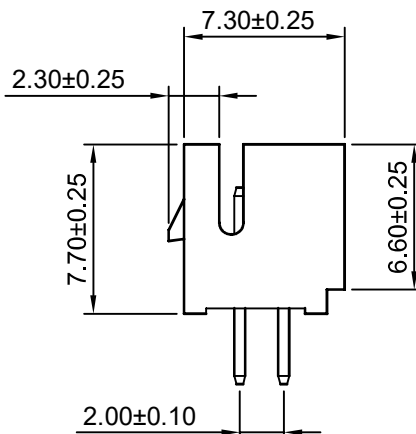
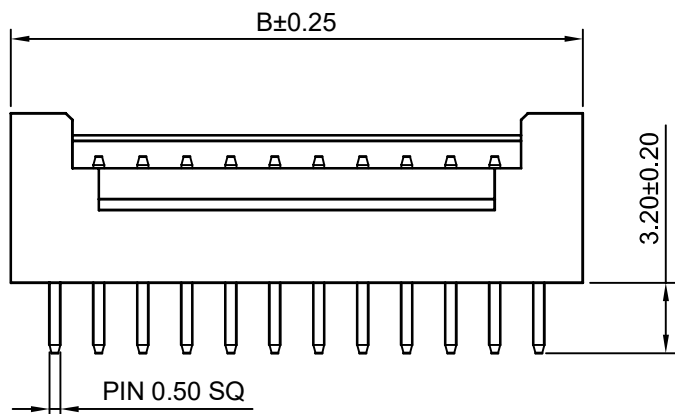
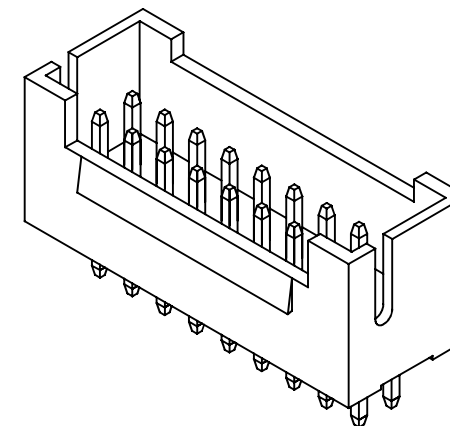
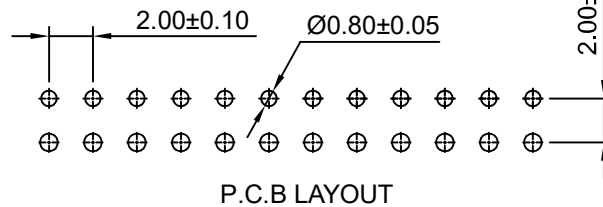
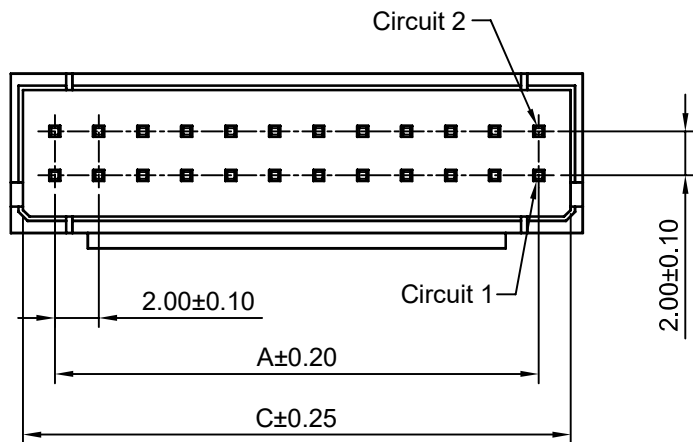

Ordering Information & Dimensions

Circuits	Dimensions(mm)			Circuits	Dimensions(mm)		
	A	B	C		A	B	C
2x3P	4.00	8.00	6.80	2x12P	22.00	26.00	24.80
2x4P	6.00	10.00	8.80	2x13P	24.00	28.00	26.80
2x5P	8.00	12.00	10.80	2x14P	26.00	30.00	28.80
2x6P	10.00	14.00	12.80	2x15P	28.00	32.00	30.80
2x7P	12.00	16.00	14.80	2x16P	30.00	34.00	32.80
2x8P	14.00	18.00	16.80	2x17P	32.00	36.00	34.80
2x9P	16.00	20.00	18.80	2x18P	34.00	38.00	36.80
2x10P	18.00	22.00	20.80	2x19P	36.00	40.00	38.80
2x11P	20.00	24.00	22.80	2x20P	38.00	42.00	40.80

SPECIFICATIONS:

Current Rating: 3A AC,DC
Voltage Rating: 250V AC,DC
Temperature Range: -25°C ~ +85°C
Contact Resistance: 30mΩ Max
Insulation Resistance: 1000MΩ Min
Withstanding Voltage: 1000V AC/minute
Pin Material: Brass/Tin-Plated
Material: Nylon 66,UL94V-0(White)



深圳市华德共创科技有限公司
Shenzhen Huade co-create Technology Co.,LTD
TEL : 0755-27129737 FAX : 0755-29940187

-TOLERANCES- UNLESS OTHERWISE SPECIFIED 公差参数表				TITLE: 产品名称: 2.00mm Pitch 180° Wafer	
X.X	±0.30	X.X°	±3°	APPD: 核准:	XIE
X.XX	±0.30	X.XX°	±2°	CHECK: 校对:	WANG
X.XXX	±0.10	X.XXX°	±1°	DRAW: 绘图:	WANG
PART NO: 产品编号:		HDGC2008WV-2xXP			
DATE	SCALE	UNIT	CODE NUMBER		
2014-06-18	3:1	mm	A008		

修订 REV	标记 MARK	修改摘要 REVISION DESCRIPTION	签名 SIGNATURE	日期 DATE
AO		NEW RELEASE	WANG	2014-06-18

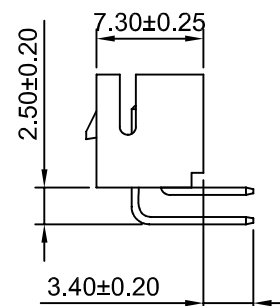
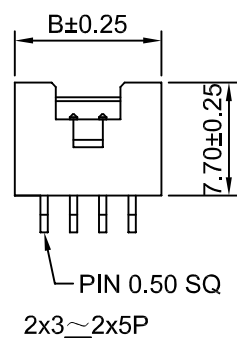
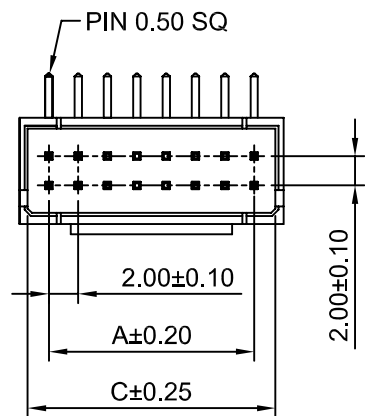
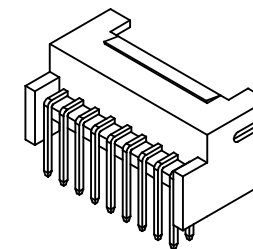
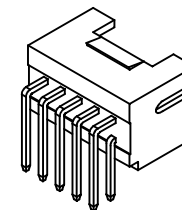
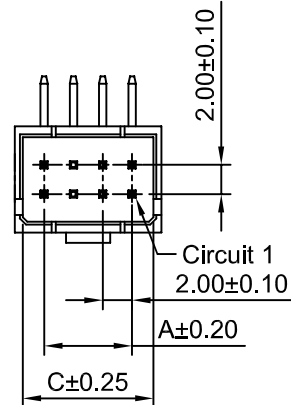
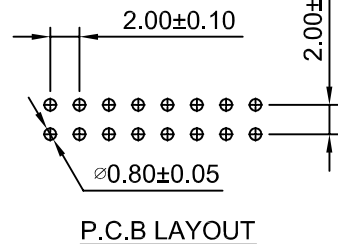

Ordering Information & Dimensions

Circuits	Dimensions(mm)			Circuits	Dimensions(mm)		
	A	B	C		A	B	C
2x3P	4.00	8.00	6.80	2x12P	22.00	26.00	24.80
2x4P	6.00	10.00	8.80	2x13P	24.00	28.00	26.80
2x5P	8.00	12.00	10.80	2x14P	26.00	30.00	28.80
2x6P	10.00	14.00	12.80	2x15P	28.00	32.00	30.80
2x7P	12.00	16.00	14.80	2x16P	30.00	34.00	32.80
2x8P	14.00	18.00	16.80	2x17P	32.00	36.00	34.80
2x9P	16.00	20.00	18.80	2x18P	34.00	38.00	36.80
2x10P	18.00	22.00	20.80	2x19P	36.00	40.00	38.80
2x11P	20.00	24.00	22.80	2x20P	38.00	42.00	40.80

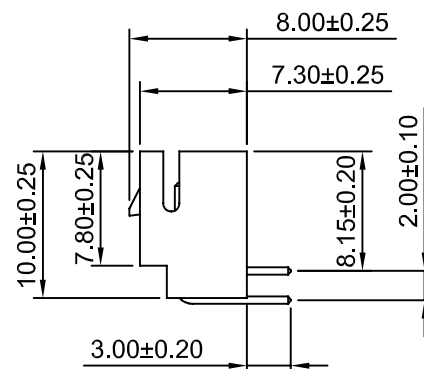
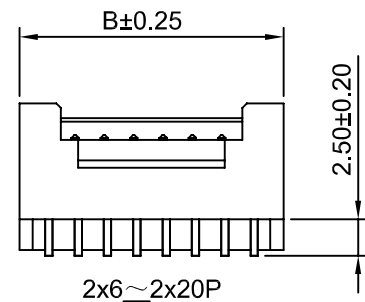

SPECIFICATIONS:

Current Rating: 3A AC,DC
Voltage Rating: 250V AC,DC
Temperature Range:-25°C ~ +85°C
Contact Resistance: 30mΩ Max
Insulation Resistance: 1000MΩ Min
Withstanding Voltage: 1000V AC/minute
Pin Material:Brass/Tin over Nickel
Material: Nylon 66,UL94V-0(White)



深圳市华德共创科技有限公司

Shenzhen Huade co-create Technology Co.,LTD

TEL : 0755-27129737 FAX : 0755-29940187

-TOLERANCES- UNLESS OTHERWISE SPECIFIED 公差参数表				 		TITLE: 产品名称: 2.00mm Pitch 90° Wafer			
X.X	±0.30	X.X°	±3°	APPD: 核准:	XIE	PART NO: 产品编号: HDGC2008WR-2xXP			
X.XX	±0.30	X.XX°	±2°	CHECK: 校对:	WANG	DATE	SCALE	UNIT	CODE NUMBER
X.XXX	±0.10	X.XXX°	±1°	DRAW: 绘图:	WANG	2014-06-18	2:1	mm	A008

修订 REV	标记 MARK	修改摘要 REVISION DESCRIPTION	签名 SIGNATURE	日期 DATE
AO		NEW RELEASE	WANG	2014-06-18

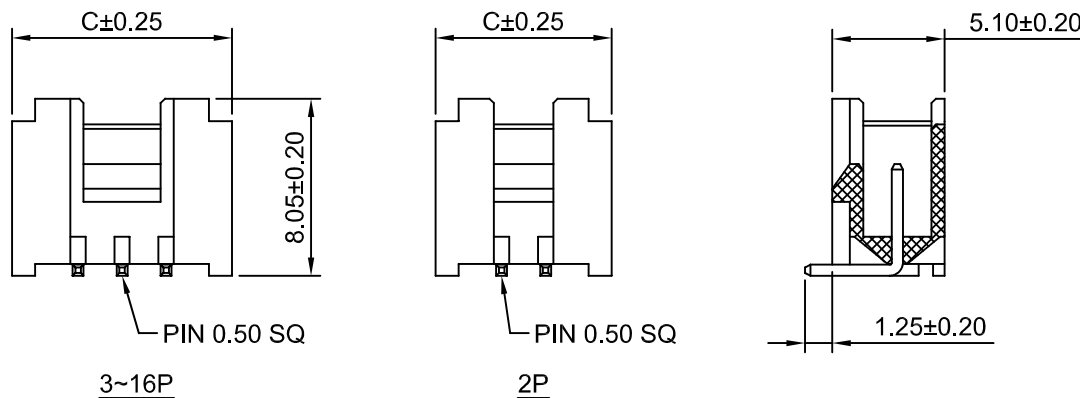
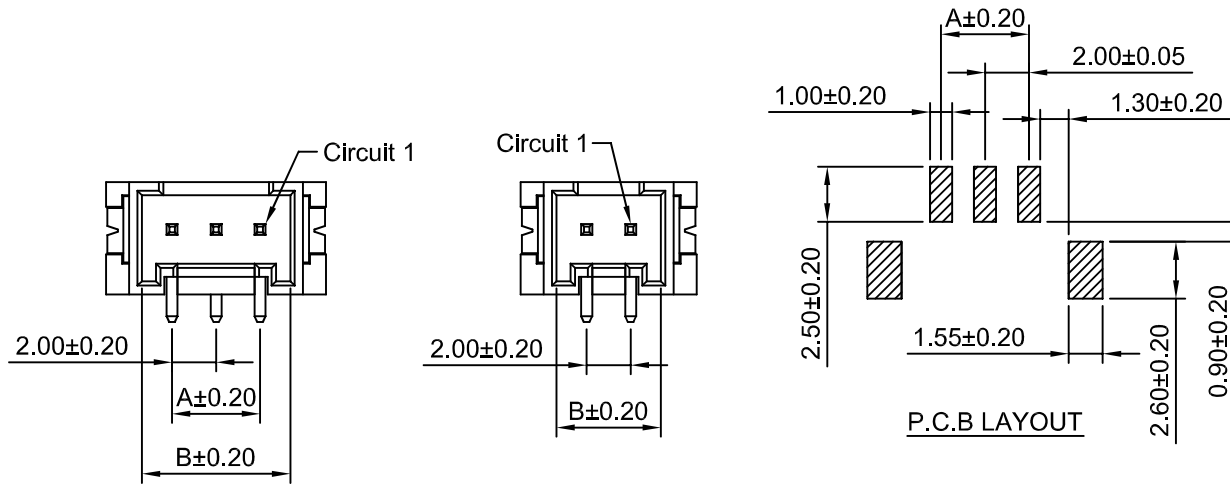

Ordering Information & Dimensions

Circuits	Dimensions(mm)			Circuits	Dimensions(mm)		
	A	B	C		A	B	C
2P	2.00	4.75	8.00	10P	18.00	20.75	24.00
3P	4.00	6.75	10.00	11P	20.00	22.75	26.00
4P	6.00	8.75	12.00	12P	22.00	24.75	28.00
5P	8.00	10.75	14.00	13P	24.00	26.75	30.00
6P	10.00	12.75	16.00	14P	26.00	28.75	32.00
7P	12.00	14.75	18.00	15P	28.00	30.75	34.00
8P	14.00	16.75	20.00	16P	30.00	32.75	36.00
9P	16.00	18.75	22.00				

SPECIFICATIONS:

Current Rating: 3A AC,DC
Voltage Rating: 250V AC,DC
Temperature Range: -25°C ~ +85°C
Contact Resistance: 30mΩ Max.
Insulation Resistance: 1000MΩ Min.
Withstanding Voltage: 1000V AC/minute
PIN Material: Brass/Tin over Nickel
Material: LCP, UL94V-0(Ivory)



深圳市华德共创科技有限公司

Shenzhen Huade co-create Technology Co.,LTD
TEL : 0755-27129737 FAX : 0755-29940187

-TOLERANCES- UNLESS OTHERWISE SPECIFIED 公差参数表						TITLE: 产品名称: 2.00mm Pitch 180° Wafer			
X.X	±0.30	X.X°	±3°	APPD: 核准:	XIE	PART NO: 产品编号: HDGC2008WV-S-XP			
X.XX	±0.30	X.XX°	±2°	CHECK: 校对:	WANG	DATE	SCALE	UNIT	CODE NUMBER
X.XXX	±0.10	X.XXX°	±1°	DRAW: 绘图:	WANG	2014-06-18	3:1	mm	A008

修订 REV	标记 MARK	修改摘要 REVISION DESCRIPTION	签名 SIGNATURE	日期 DATE
AO		NEW RELEASE	WANG	2014-06-18

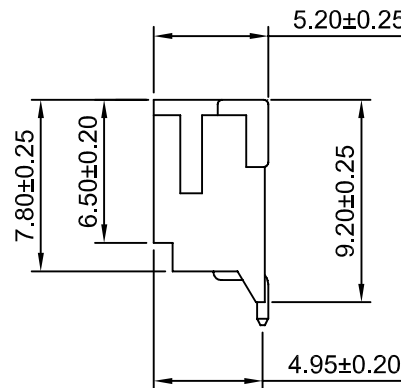
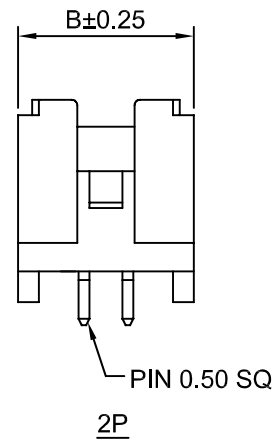
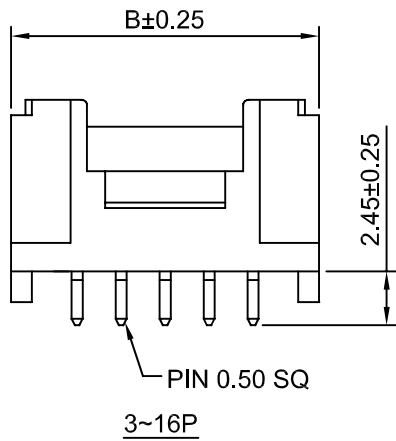
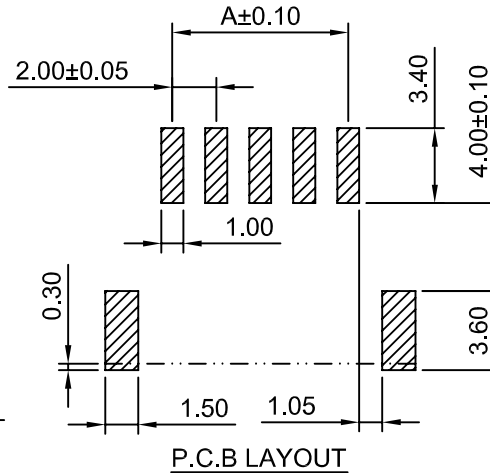
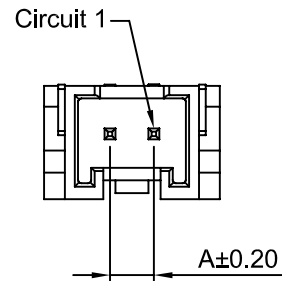
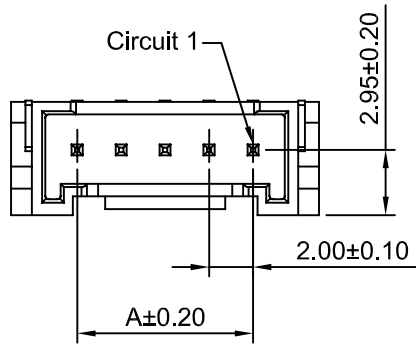

Ordering Information & Dimensions

Circuits	Dimensions(mm)		Circuits	Dimensions(mm)	
	A	B		A	B
2P	2.00	8.00	10P	18.00	24.00
3P	4.00	10.00	11P	20.00	26.00
4P	6.00	12.00	12P	22.00	28.00
5P	8.00	14.00	13P	24.00	30.00
6P	10.00	16.00	14P	26.00	32.00
7P	12.00	18.00	15P	28.00	34.00
8P	14.00	20.00	16P	30.00	36.00
9P	16.00	22.00			

SPECIFICATIONS:

Current Rating: 3A AC,DC
Voltage Rating: 250V AC,DC
Temperature Range: -25°C ~ +85°C
Contact Resistance: 30mΩ Max
Insulation Resistance: 1000MΩ Min
Withstanding Voltage: 1000V AC/minute
Pin Material: Brass/Tin over Nickel
Material: Nylon 6T,UL94V-0(Beige)



深圳市华德共创科技有限公司

Shenzhen Huade co-create Technology Co.,LTD
TEL : 0755-27129737 FAX : 0755-29940187

-TOLERANCES- UNLESS OTHERWISE SPECIFIED 公差参数表				 TITLE: 2.00mm Pitch 产品名称: 90° Wafer					
X.X	±0.30	X.X°	±3°	APPD: 核准:	XIE	PART NO: 产品编号: HDGC2008WR-S-XP			
X.XX	±0.30	X.XX°	±2°	CHECK: 校对:	WANG	DATE	SCALE	UNIT	CODE NUMBER
X.XXX	±0.10	X.XXX°	±1°	DRAW: 绘图:	WANG	2014-06-18	3:1	mm	A008

修订 REV	标记 MARK	修改摘要 REVISION DESCRIPTION	签名 SIGNATURE	日期 DATE
AO		NEW RELEASE	WANG	2014-06-18

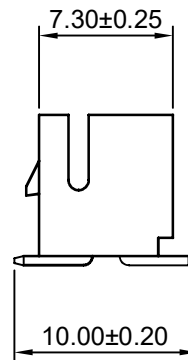
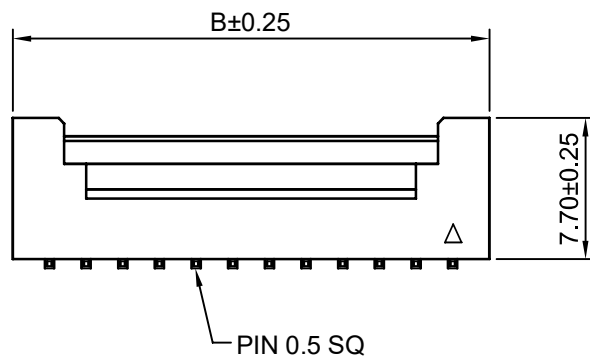
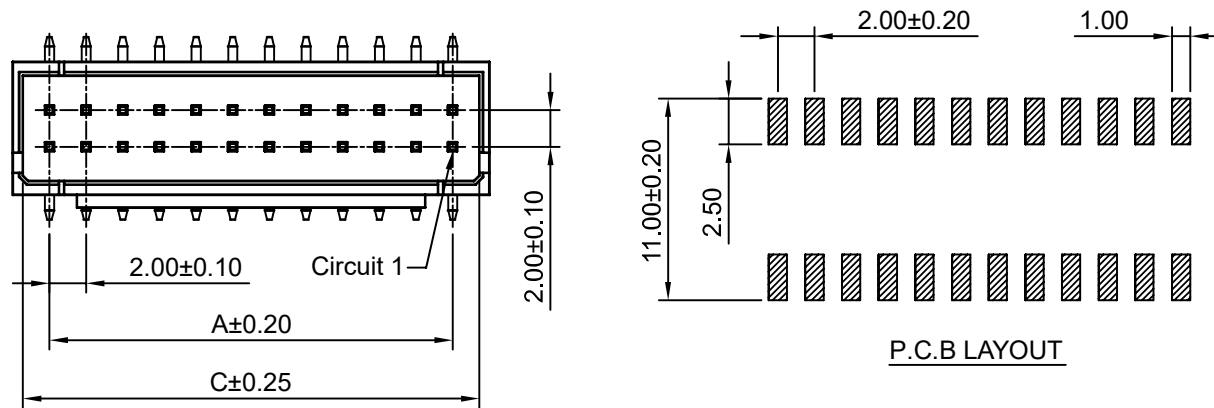

Ordering Information & Dimensions

Circuits	Dimensions(mm)			Circuits	Dimensions(mm)		
	A	B	C		A	B	C
2x3P	4.00	8.00	6.80	2x12P	22.00	26.00	24.80
2x4P	6.00	10.00	8.80	2x13P	24.00	28.00	26.80
2x5P	8.00	12.00	10.80	2x14P	26.00	30.00	28.80
2x6P	10.00	14.00	12.80	2x15P	28.00	32.00	30.80
2x7P	12.00	16.00	14.80	2x16P	30.00	34.00	32.80
2x8P	14.00	18.00	16.80	2x17P	32.00	36.00	34.80
2x9P	16.00	20.00	18.80	2x18P	34.00	38.00	36.80
2x10P	18.00	22.00	20.80	2x19P	36.00	40.00	38.80
2x11P	20.00	24.00	22.80	2x20P	38.00	42.00	40.80

SPECIFICATIONS:

Current Rating: 3A AC,DC
 Voltage Rating: 250V AC,DC
 Temperature Range: -25°C ~ +85°C
 Contact Resistance: 30mΩ Max
 Insulation Resistance: 1000MΩ Min
 Withstanding Voltage: 1000V AC/minute
 Pin Material: Brass/Tin over Nickel
 Material: Nylon 6T,UL94V-0(Ivory)



深圳市华德共创科技有限公司

Shenzhen Huade co-create Technology Co.,LTD
 TEL : 0755-27129737 FAX : 0755-29940187

-TOLERANCES- UNLESS OTHERWISE SPECIFIED 公差参数表						TITLE: 产品名称: 2.00mm Pitch 180° Wafer			
X.X	±0.30	X.X°	±3°	APPD: 核准:	XIE	PART NO: 产品编号: HDGC2008WV-S-2xXP			
X.XX	±0.30	X.XX°	±2°	CHECK: 校对:	WANG	DATE	SCALE	UNIT	CODE NUMBER
X.XXX	±0.10	X.XXX°	±1°	DRAW: 绘图:	WANG	2014-06-18	2.5:1	mm	A008

修订 REV	标记 MARK	修改摘要 REVISION DESCRIPTION	签名 SIGNATURE	日期 DATE
AO		NEW RELEASE	WANG	2014-06-18

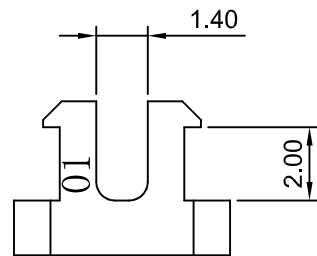

2P

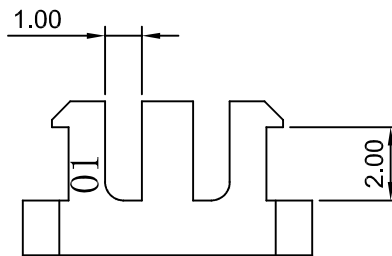

3P

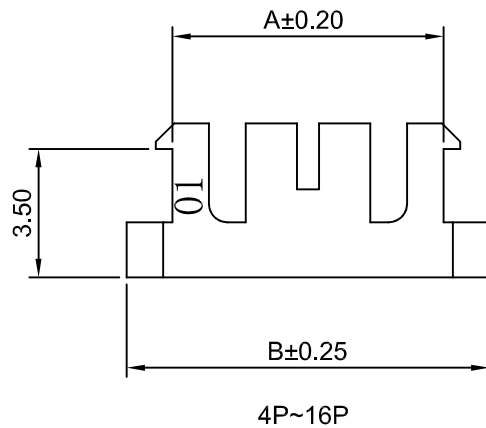
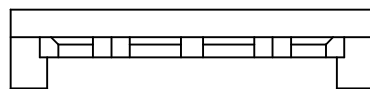
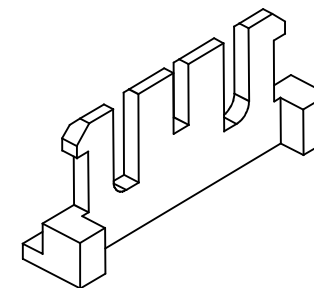

4P~16P

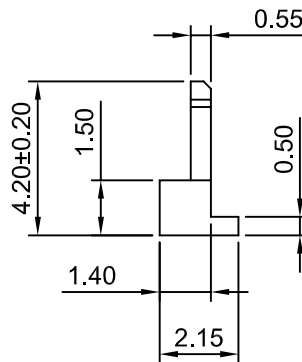

Ordering Information & Dimensions

Circuits	Dimensions(mm)		Circuits	Dimensions(mm)	
	A	B		A	B
2P	3.40	5.90	10P	19.40	21.90
3P	5.40	7.90	11P	21.40	23.90
4P	7.40	9.90	12P	23.40	25.90
5P	9.40	11.90	13P	25.40	27.90
6P	11.40	13.90	14P	27.40	29.90
7P	13.40	15.90	15P	29.40	31.90
8P	15.40	17.90	16P	31.40	33.90
9P	17.40	19.90			

SPECIFICATIONS:

Current Rating: 3A AC,DC
Voltage Rating: 250V AC,DC
Temperature Range: -25°C ~ +85°C
Contact Resistance: 30mΩ Max.
Insulation Resistance: 1000MΩ Min.
Withstanding Voltage: 1000V AC/minute
Material: Nylon 66, UL94V-0(Brick red)



深圳市华德共创科技有限公司

Shenzhen Huade co-create Technology Co.,LTD

TEL : 0755-27129737 FAX : 0755-29940187

-TOLERANCES- UNLESS OTHERWISE SPECIFIED 公差参数表						TITLE: 产品名称: 2.00mm Pitch Seal			
X.X	±0.30	X.X°	±3°	APPD: 核准:	XIE	PART NO: 产品编号: HDGC2008S-XP			
X.XX	±0.30	X.XX°	±2°	CHECK: 校对:	WANG	DATE	SCALE	UNIT	CODE NUMBER
X.XXX	±0.10	X.XXX°	±1°	DRAW: 绘图:	WANG	2014-06-18	5:1	mm	A008